

1995 FORD

CONTOUR



CONTOUR

Introducing the Ford Contour. Seldom does bringing an all-new car to market generate for us so much excitement. That's because Contour is so much more than just a new car.

Contour is a World Car, created from the ground up by the best and most innovative minds in our worldwide Ford company.

Contour is, literally, a world apart from any 4-door sedan in its class that we have ever built in the United States.

COMPREHENSIVE DYNAMIC SAFETY ENGINEERING

Contour's Dynamic Safety Engineering system delivers precise handling, steering and braking—the "operating safety" features that are designed to help you avoid an accident.

Not only is an Anti-lock Brake System (ABS) available, but there's an Electronic All-Speed Traction Control system coupled with ABS—a feature only a few other cars in the world offer.

Vital also are the "occupant safety" features that help provide protection should an accident occur, such as the "safety cell" body structure, dual air bag supplemental restraint systems, and seats that are specially designed to help hold you in place, to mention just a few.

While designing Contour's Dynamic Safety Engineering,

we did more than what you might expect by putting Contour through special safety testing that the Federal Government does not require.

A WORLD OF COMFORTS, SURPRISES AND DELIGHTS

To provide for your pleasure and riding comfort, we thought of just about everything. Solar tinted glass, height-adjustable front shoulder belts, illuminated switches and controls—these are some of the many features you'll discover in Ford Contour.

What's more, standard in Contour is the MicronAir® Filtration System that keeps virtually all pollen, road dust and other particulates from entering the car. Until now, it was a feature you'd find only in some expensive luxury cars.

A DRIVING EXPERIENCE THAT WILL REWARD YOU

Until you drive a Ford Contour, you may never feel just how well a sedan in this class can perform.

While considerable effort went into Contour's advanced comfort and safety zones, we never lost sight of what driving a Contour is all about. Driving.

Experience the responsive multi-valve, dual overhead cam Zetec 2.0-liter I-4 engine or Duratec V-6 System.

Enjoy superbly balanced ride quality and handling agility from the 4-wheel independent suspension with sophisticated "quadra-link" rear system.

The all-new Ford Contour.

A World Car for the 21st Century.

Yours to drive and enjoy today.

SE

Contour SE sport sedan in Champagne Clearcoat Metallic. Among SE's features are fog lamps, rear spoiler, 15" cast aluminum wheels, and the Duratec 2.5-liter V-6 System. Some equipment shown, such as the 7-spoke cast aluminum wheels (see your dealer for availability), is optional.



A DRIVER'S CAR

Advanced as Contour's ergonomic design is, it's actually based on a rather simple premise: A car that is easier and more comfortable to drive is more enjoyable to drive, and safer to operate as well.

In Contour, outstanding ergonomics combines with precision-engineered powertrain, suspension, steering and braking systems to create a driver's car that not only imparts a feeling of satisfaction, but also inspires a strong sense of confidence.

"HUMAN-ENGINEERED" FOR COMFORT AND SAFETY

Once seated at the wheel of a Contour, notice how well designed and logically arranged the instruments and controls are.

Controls are high on the instrument panel and placed where they can be reached easily. Some are right at your fingertips on column-mounted levers. Illuminated "tactile" controls and rotary switches are easily found and can be operated without having to take your eyes from the road. The instruments are sized, located and colored to make them easy to read at a glance.

Notice, too, Contour's seating, which is firm and supportive and designed to minimize fatigue, especially over long trips. Plus features such as the driver's left footrest and the height-adjustable front shoulder belts for personalized comfort.

Also, there are features that enhance visibility. For example, the cowl (between the hood and the windshield) is designed to remove rain water pushed down by the wipers. And catchers in the front pillars help keep water off the side windows and mirrors. You might say we tried to think of just about everything, for your comfort and your safety.

At right and on pages 6-7: The Contour SE instrument panel and interior in Pumice. Standard are reclining sport cloth buckets, tachometer, leather-wrapped steering wheel, full-length center console, split fold-down rear seat backs and much more. Some equipment shown, such as the leather seating surfaces, is optional.





LUXURY & COMFORT



In Contour's list of standard and optional equipment, you'll discover a lot of what are called "surprise and delight" features: things you might not expect.

UNEXPECTED COMFORTS AND CONVENIENCES

One such feature is "solar" tinted glass. It reduces heat build-up, especially when you're parked, and it facilitates faster cooling time when the

air conditioning is turned on. Standard also are height-adjustable front shoulder belts, so no matter whether you're tall or short, you can adjust your belt to get the right fit.

FEATURES YOU'D EXPECT IN LARGER, MORE EXPENSIVE AUTOMOBILES

Contour treats you and your passengers to comforts you normally wouldn't expect to find in a car in Contour's class.

Take, as a good example, the MicronAir® Filtration System described and illustrated on page 16. You once would have had to

go to an expensive luxury car to get it—but that was before it was made standard in Contour.

TRACTION CONTROL, 10-WAY POWER SEAT, AND MORE

The electronic All-Speed Traction Control System option with ABS brakes (detailed on page 19) is a feature only a few other cars make available.

The optional 10-way power driver's seat (for Contour LX)

provides lumbar inflate/deflate, up/down, forward/back and tilt forward/back adjustments, plus a power seat back recliner.

There are many other fine features as well, including: Optional leather seating surfaces. Lighted door handles (in the optional Light Group). Optional power moonroof. And available power windows that allow the driver's window to be lowered completely at "one touch" of a switch. Contour models with power windows also permit the driver to lock the rear windows—for when kids are in the back seat—a nice safety feature.

LX

The Contour LX in Electric Clearcoat Metallic. Fog lamps and body-color power mirrors standard. Some equipment may be optional.

EFFICIENCY & VALUE

To make Contour as complete a car as possible, to satisfy all of your driving requirements, we have paid as much attention to your needs for efficiency and value as for style and comfort.

HIGH POWER-EFFICIENCY

With their free-breathing multi-valve design, dual overhead cams, sophisticated computer controls, lightweight yet strong components and advanced transaxles, Contour's Zetec 2.0-liter I-4 engine and 2.5-liter Duratec V-6 System generate a lot of power. Given their displacements, these engines are remarkably "power-efficient."

REDUCED MAINTENANCE

The electronic distributorless ignition system. Long-life platinum-tipped spark plugs. Initial coolant replacement not required until four years or 50,000 miles. These are just a few of the many features contributing to reduced maintenance.

What's more, the optional 2.5-liter Duratec V-6 can travel 100,000 miles (the equivalent to four trips around the world) before requiring its first tune-up.

VALUE AND CUSTOMER SATISFACTION

Knowing you're getting a lot for what you've paid—that's what value is all about. You'll find a lot of value in any one of Contour's three models, beginning with the Contour GL.

Contour GL is equipped with an impressive list of standard features and offers a choice of three Preferred Equipment Packages (pages 28-29).

And Contour GL, like every "customer-driven" Ford product, provides no-cost Roadside Assistance along with 3-year/36,000-mile bumper-to-bumper limited warranty coverage (page 26).

GL

The well-equipped and value-packed Contour GL in Tobago Green Clearcoat Metallic. Some equipment shown may be optional.



SUPERB DRIVING DYNAMICS

We have made the Contour a stylish and roomy, 5-passenger 4-door sedan possessing a level of comfort that rises above what you might expect to experience.

And Contour provides as well a degree of performance, ride quality and handling that should also pleasantly surprise you.

SMOOTH AND AGILE FOR DRIVING ENJOYMENT

In design and engineering, Contour is intended to be, first and foremost, a driver's car.

The distinct feeling you get of firm handling and solid stability results from precision-engineered suspension and steering systems, as well as a highly aerodynamic body design that's shaped along advanced air flow management principles.

Contour has power-assisted rack-and-pinion steering for a firm and precise feel of the road. The independent strut front suspension has controlled geometry and refined tuning for tight handling, while features such as

the hydromount lower A-arm bushings provide a high degree of ride smoothness and comfort.

The "quadra-link" rear suspension system with passive rear wheel steering capability is designed to provide highly accurate wheel control—which it accomplishes by producing a "toe-in" effect to counteract the car's natural tendency to "toe-out" under the forces of cornering and braking.

Also, just as you'd expect in a driver's car, the front and rear suspensions are outfitted with an anti-roll bar.

What's more, it's by no mere accident that the Contour looks every bit as dynamic as it corners and handles. That's because we purposefully shaped the body so that "form follows function" naturally and beautifully.

Contour's "low-lift" aerodynamic shape combines with the suspension's handling capability, the enhanced ride quality and control of a long 106.5" wheelbase (longer than many much larger cars) and a low center of gravity to deliver added stability, even in strong crosswinds.

And when it comes to underhood performance, the all-new Zetec 2.0-liter I-4 engine and Duratec 2.5-liter V-6 System each have plenty of power to surprise and delight you.

Both engines feature four valves per cylinder actuated by dual overhead cams, plus state-of-the-art sequential electronic fuel injection controlled by Ford's EEC-IV computer.

TIGHT AND RESPONSIVE FOR DRIVING CONFIDENCE

There's only one thing more important than driving enjoyment. And that's driving safety.

More often than not, safe driving comes down to how well you are in control of the driving situation, whether it be an emergency maneuver or a routine changing of a lane.

So we carefully engineered the "operating safety" features—the suspension, steering and braking systems—not only to make driving enjoyable but also to help you avoid an accident.

Combine their effectiveness with your awareness and driving skills and hopefully Contour's "occupant safety" features—the air bag supplemental restraint systems, for example—won't ever have to be needed.

Everything combined, we call it Dynamic Safety Engineering.

The "quadra-link" independent rear suspension system with passive rear wheel steering and anti-roll bar provides highly accurate wheel control. It does so by producing a "toe-in" effect to counteract the car's natural tendency to "toe-out" under the forces of cornering and braking.

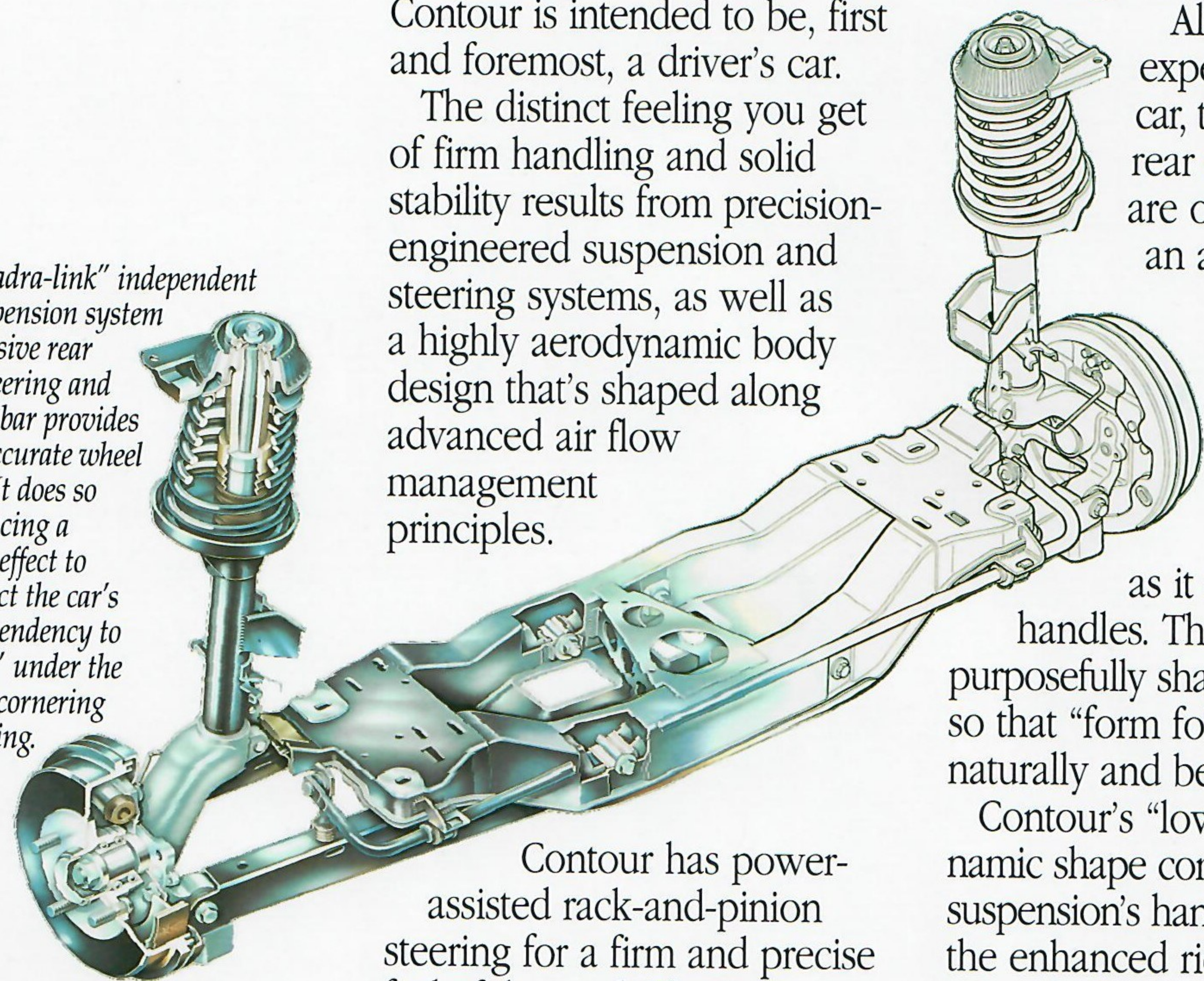

DYNAMIC SAFETY ENGINEERING

"Operating safety" features—the suspension, steering and braking systems—can provide stability and control to help you avoid an accident. But if an accident occurs, "occupant safety" features come into play to help protect you.

In a Ford Contour, you can feel assured that we went to great lengths to provide the protection you would expect. And then some.

Fact is, in designing Contour's Dynamic Safety Engineering system, we went beyond what you might expect by putting Contour through testing the government does not require.

AN EFFECTIVE "SAFETY CELL" THAT'S ALL AROUND YOU

The unitized body has been carefully engineered to provide a high degree of protection. Consider a few examples.

The front end structure has a reinforced subframe and a cross beam between the pillars. High-tensile steel door beams, designed as integral parts of the body structure, provide added protection from a side impact. The sheet metal at the front and

rear corners collapses progressively to dissipate the shock of impact. Specially designed rocker beams help keep the front wheels from being pushed into the passenger compartment.

Also, the fuel system was tested to exceed the most stringent standards. The tank is forward of the rear suspension, as far from the impact area as possible. And in the event of an accident, an inertia switch in the front footwell automatically shuts off the fuel supply.

AND INSIDE, SAFETY FEATURES AND DESIGNS VIRTUALLY EVERYWHERE

Contour's front and rear seats not only provide firm, supportive comfort. They are also designed to help keep occupants from sliding forward under the safety belts during an accident.

Remember, though, that this special safety design depends on your wearing safety belts. So always buckle up.

There are some notable safety belt design features as well. In an impact or during emergency braking, sensors in the driver's safety belt inertia reels activate clamps that grab and hold the belt webbing. This prevents the belts from paying out, providing added protection from contact with the steering wheel.

Also, the height of the front shoulder belts is adjustable to satisfy individual comfort requirements.

Controls and switches located and designed to reduce the risk of injury; impact-absorbing dash padding; door armrests that are designed to lend

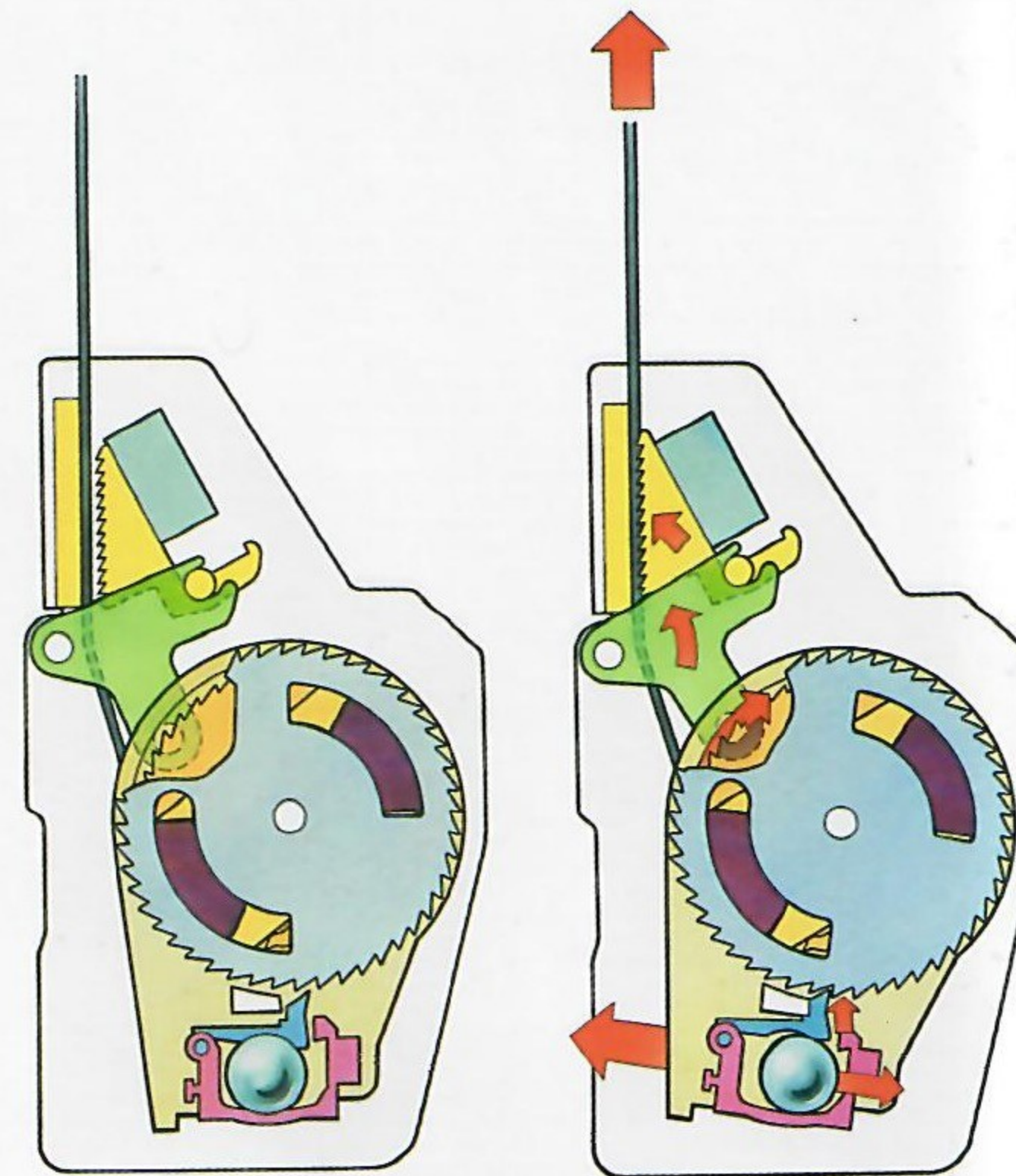

In an impact or during emergency braking, sensors inside the driver's safety belt inertia reels activate clamps that grab and hold the belt webbing. This prevents the belts from paying out, providing added protection from contact with the steering wheel.

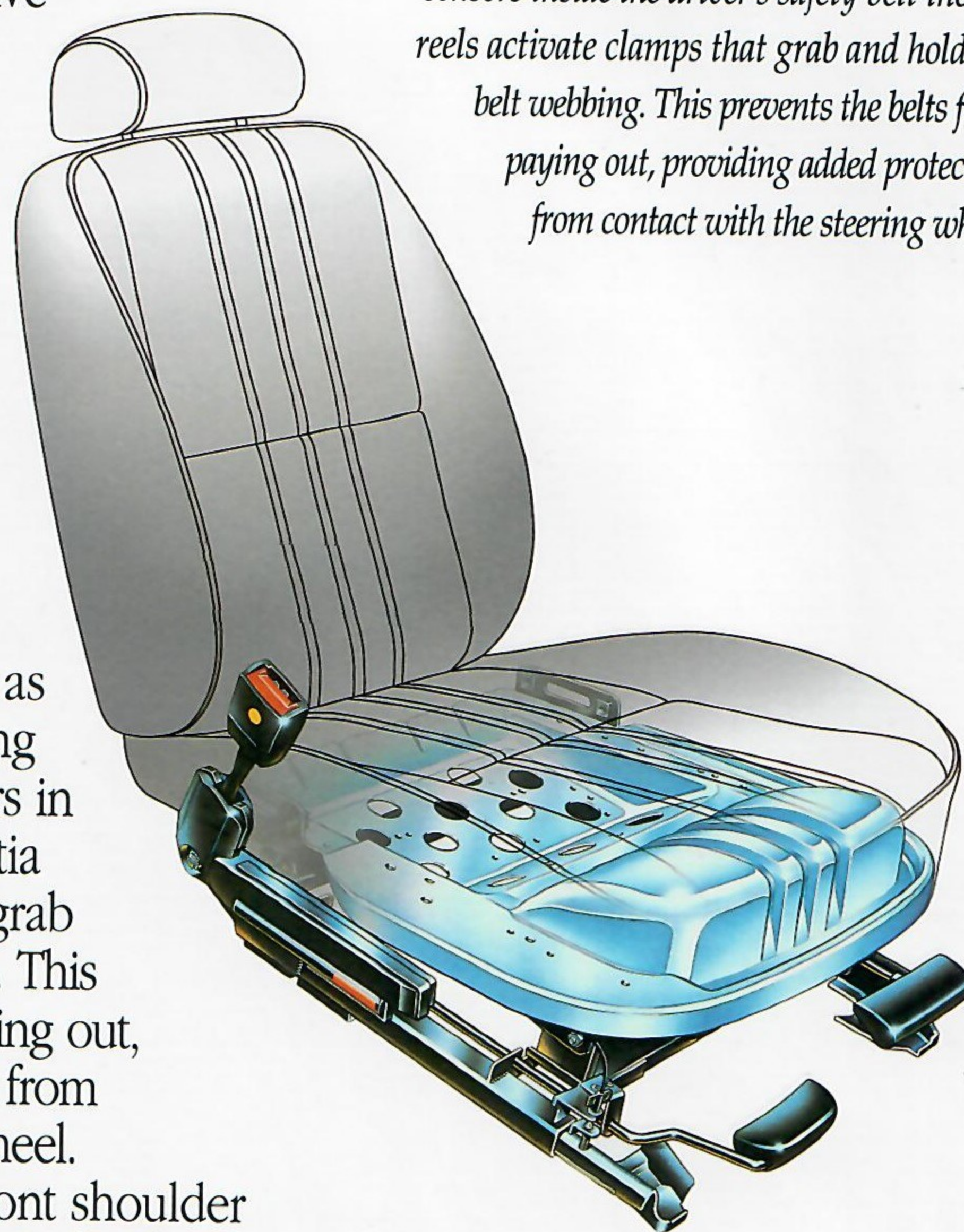

The seat frame (at all five seating positions) has a metal ramp that elevates the knee area; the front edge of the bottom cushion is reinforced to help keep the force of impact from sliding occupants forward under their safety belts.

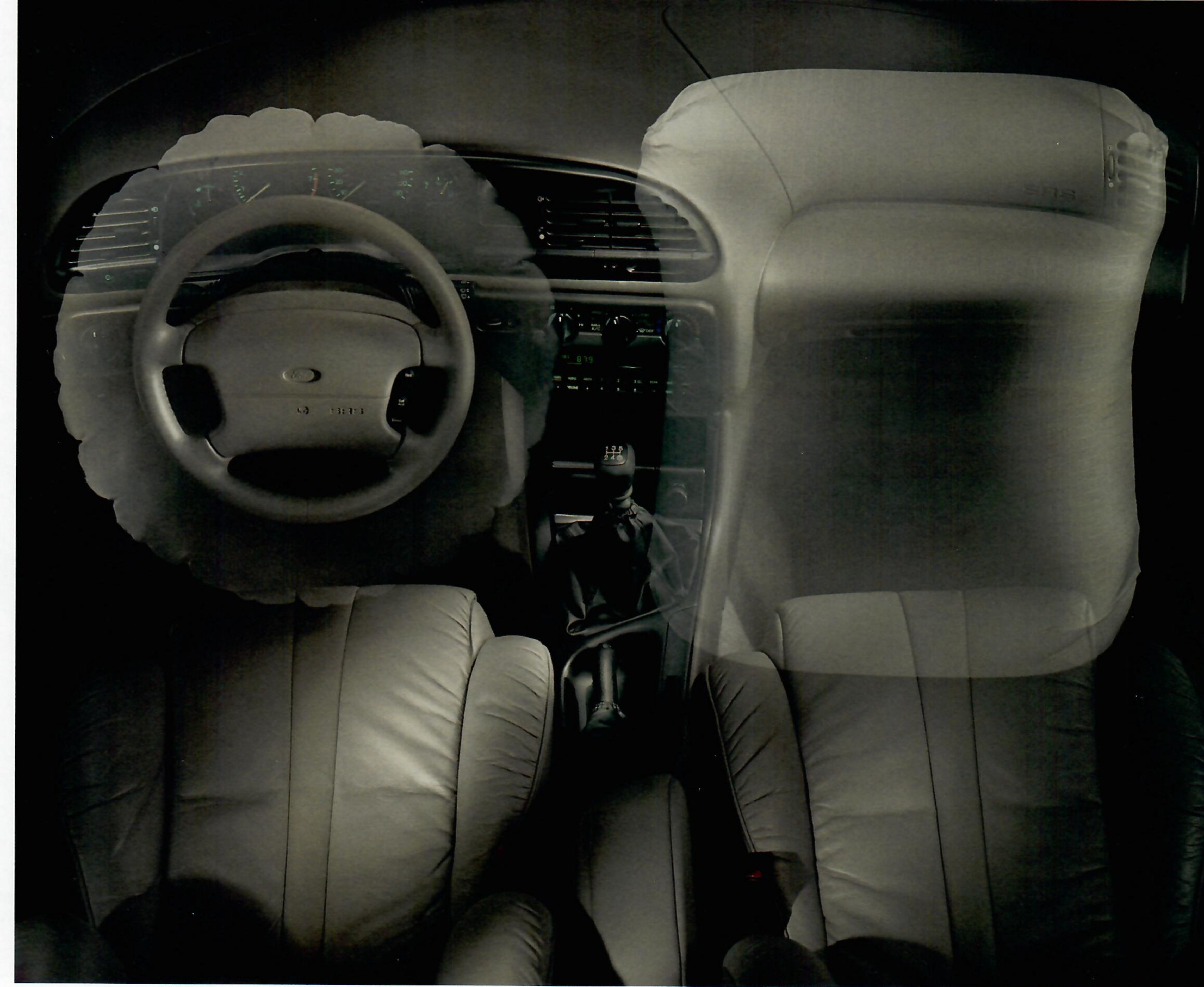

thickness to the doors and also have energy-absorbing foam bolsters—these are also among the many safety features built into every Ford Contour. Dual front air bags are standard, too.

AIR BAGS TO SUPPLEMENT THE FRONT SAFETY BELTS

The air bag is a sophisticated restraint system that activates only in certain moderate-to-severe frontal impacts.

But regardless of the advanced technology engineered into the air bag, its effectiveness in reducing the risk of head and chest injuries can be best realized only if it operates in

conjunction with your manual lap and shoulder safety belts. So be sure always to buckle up.

Contour is equipped with two air bags: one for the driver; one for the front passenger. They are two components of Contour's comprehensive Dynamic Safety Engineering system—which gives you peace of mind knowing your Ford Contour has been carefully designed for your safety.

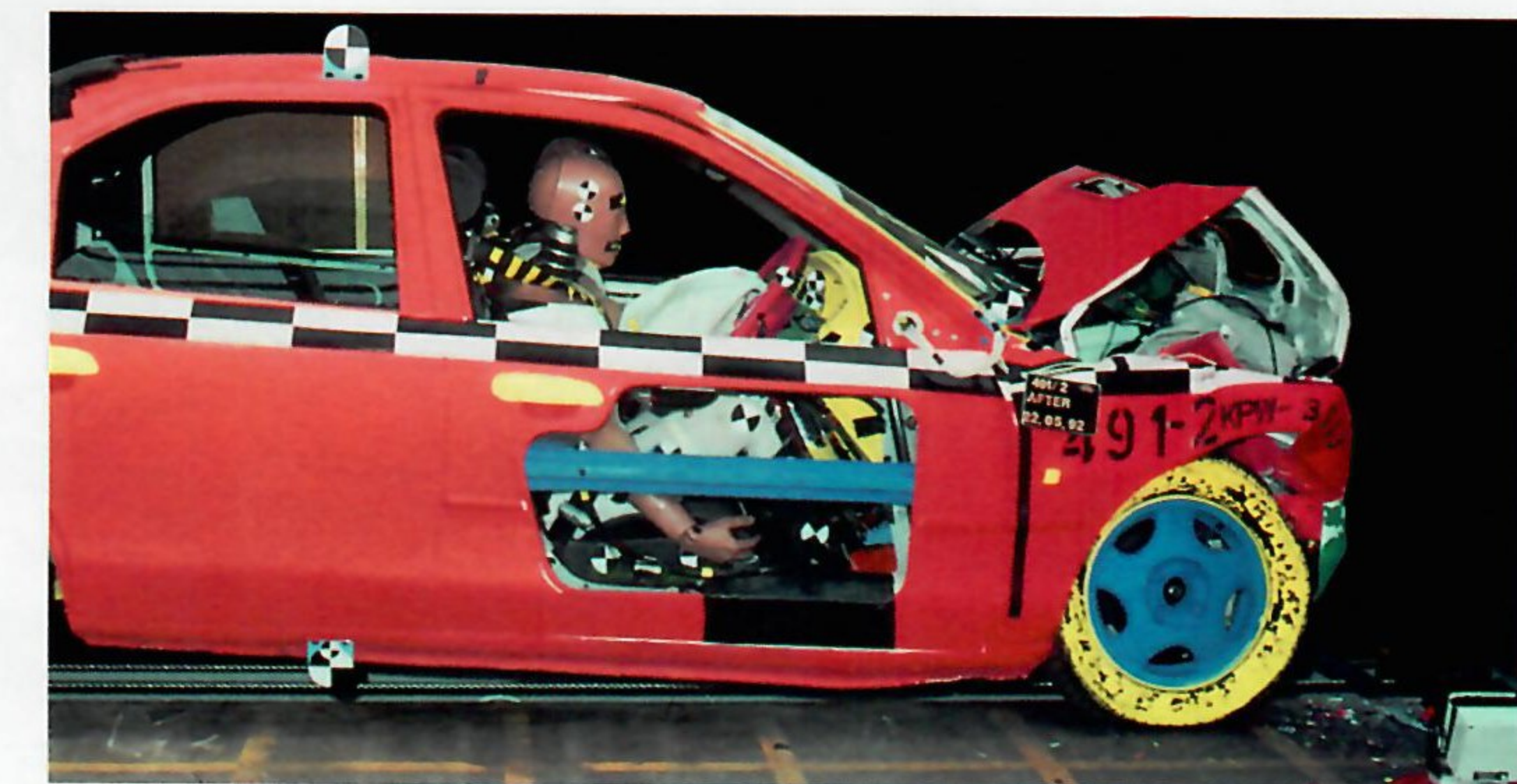

Dual air bag supplemental restraint systems, for the driver and the front passenger, are among Contour's many "occupant protection" features. Always be sure to buckle up your lap/shoulder safety belts.

Contour's "safety cell" body construction is designed to provide comprehensive protection in a frontal, side or rear end impact.

The shoulder belts have D-ring height adjusters to satisfy the comfort needs of short and tall people alike.



DESIGN & ENGINEERING



Contour's front-wheel drive provides the engineering benefit of added traction (because the weight of the engine and transaxle is over the drive wheels), plus the design benefit of extra floor space (because the drive shaft tunnel required in rear-wheel-drive cars is eliminated).

There are a lot of important things you look for in a car. Style. Fit/finish quality. Comfort and convenience. Design and engineering excellence, too.

STRONG UNITIZED BODY; DYNAMIC AERO SHAPE

The distinct feeling of solid, quiet comfort. Its foundation is the unitized body structure and the body shell that covers it.

Designed with the aid of computers, the unitized body is constructed of carefully shaped and joined panels for optimum

strength and rigidity, to provide a sturdy safety cage as well as a solid barrier against intrusive noise and vibration.

The body is designed along advanced air flow management principles, which not only strongly influence Contour's dynamic styling, but also contribute to aerodynamic efficiency, handling stability and quietness without compromising roominess and comfort.

With a low 0.31 coefficient of drag, Contour is one of the most aerodynamic cars in its class.

MICRONAIR® FILTRATION SYSTEM—EXCLUSIVE IN CONTOUR'S CLASS

Ford Contour is superbly engineered to manage the flow and quality of air inside as well. Air conditioning is included in all Preferred Equipment Packages.

And complementing Contour's climate control system is the MicronAir® Filtration System found only in some expensive luxury cars. When the windows are up, MicronAir® filters out virtually all pollen, road dust and other particulates before they can enter. It's a feature asthma and allergy sufferers will especially appreciate. And it's standard in every Ford Contour.

The MicronAir® Filtration System filters out virtually 100% of particles larger than 3 microns, which means that pollen and most road dust are removed before they can enter the car.



The front suspension subframe helps isolate the passenger compartment from road noise and provides energy-absorbing capability.

Bodywork at the corners is designed to collapse progressively, to dissipate impact shock before it reaches the passenger area.

High-tensile steel door beams are integrated into the body structure, providing protection against side impact.

Careful refinement of the body design, including the front end upper structure, pillars and roof frame, helps provide a strong "safety cell."

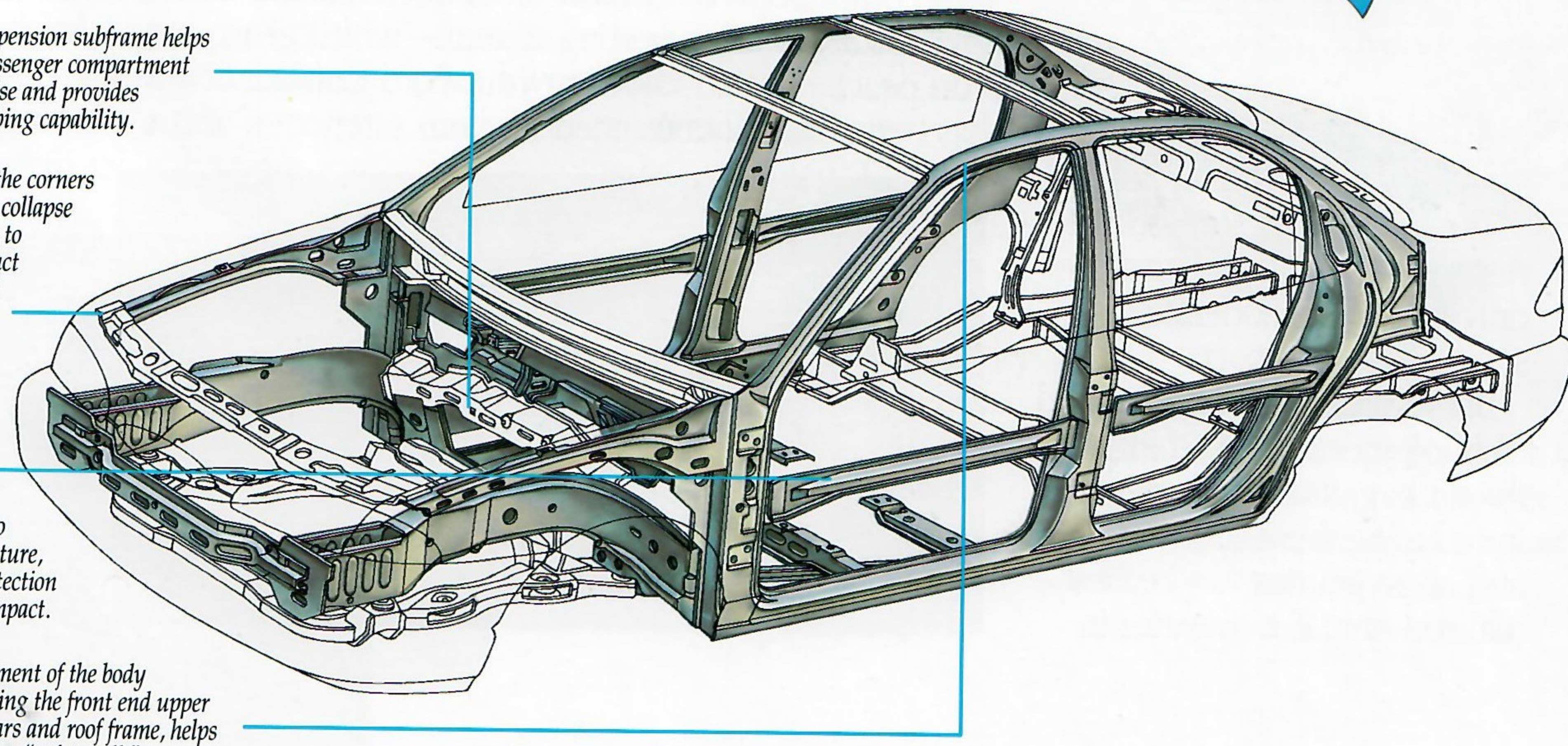

CONTOUR WAS DESIGNED FROM THE START WITH ENVIRONMENTAL CONCERNS IN MIND. SHOWN HERE ARE A FEW OF THE MATERIALS THAT CAN BE RECYCLED.

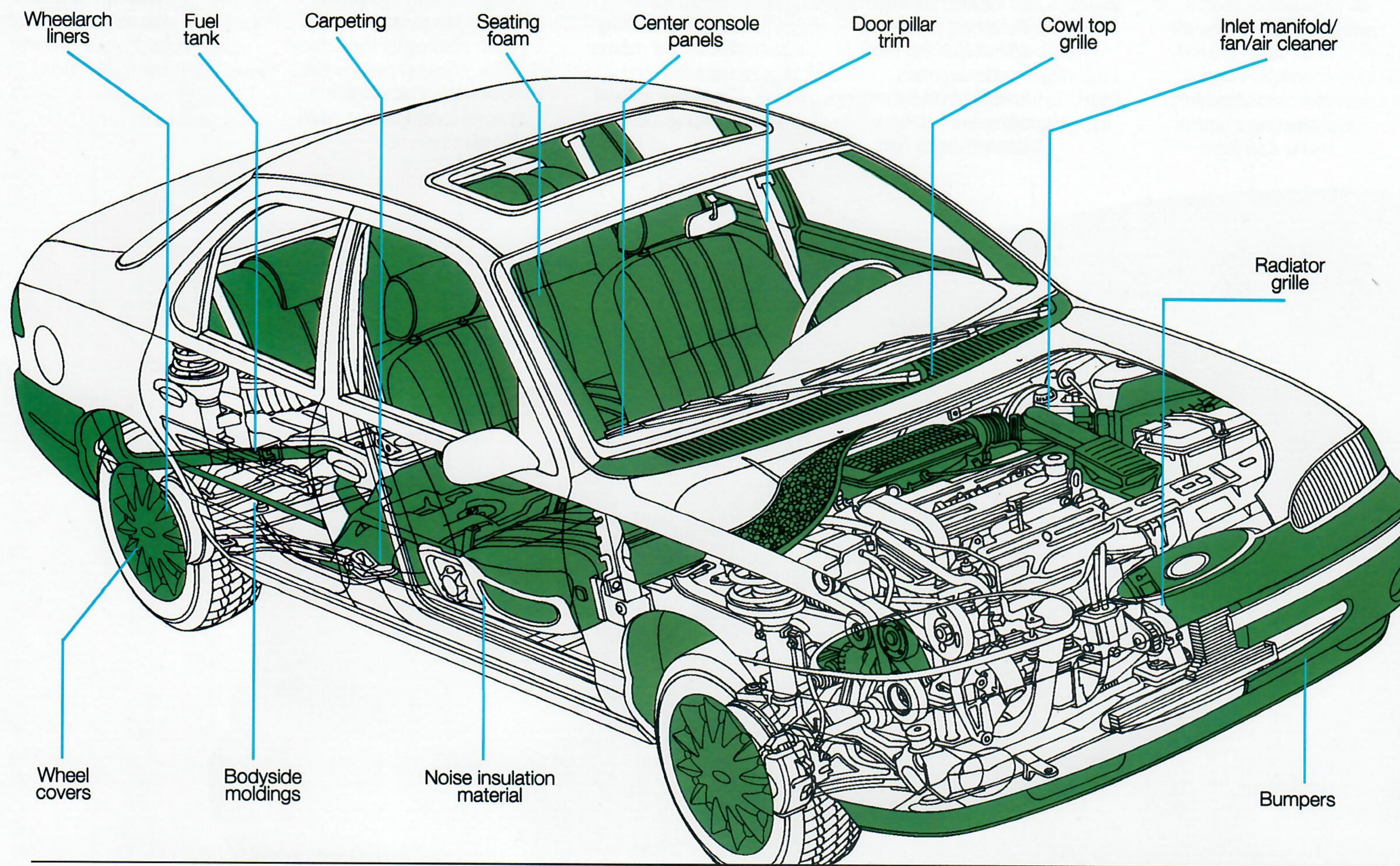

RESPONSIVE TO THE NEEDS OF THE ENVIRONMENT

From the very beginning, Ford Contour was developed with the need for a cleaner environment in mind.

Advanced-design engines are equipped with sophisticated computer control technology engineered to conserve fuel* and control emissions.

The air conditioning system uses a refrigerant containing no CFCs which can deplete the atmosphere's ozone layer.

Nearly 80% of materials are recyclable by weight (metals and fluids). Plastic parts are marked for recycling. And powertrain components make extensive

use of aluminum (60% scrap content on average). These are but a few of the ways that Ford Contour responds to the need for a cleaner environment.

COMPUTER-CONTROLLED TRACTION/BRAKING—A FEATURE ONLY A FEW OTHER CARS OFFER

Contour is one of only a few cars that offer an All-Speed Traction Control System along with an Anti-lock Brake System (ABS), optional.

The Traction Control System controls the spin of either one or both of the front wheels. Having throttle and braking control capability, it enhances traction while you're accelerating on a loose or slippery surface at any speed.

In a hard braking situation or on a slippery surface, while you're firmly holding the brake pedal, the Anti-lock Brake System keeps the wheels from locking up by applying and releasing the brakes up to 12 times per second. The results are straighter stops and greater steering control.



Contour GL and LX models have standard power front disc/rear drum brakes, while the Contour SE sport sedan has power disc brakes all around.

You can also have your Contour equipped with an optional Anti-lock Brake System (ABS). What's more, Contour offers you the added control of an optional electronic All-Speed Traction Control System (with ABS). Only a very few other cars offer this advanced system.

*EPA mileage information was unavailable at press time. See your Ford Dealer for information.

The Zetec I-4 and Duratec V-6 feature 4 valves per cylinder, dual overhead cams, sequential electronic fuel injection, mass air-flow sensor and knock sensor, and long-life platinum-tipped spark plugs among their numerous features.

The 5-speed manual transaxle has high-torque capacity. It uses a 2-rail shift linkage for fast, positive shift feel and action. It's also synchronized in all gears including reverse. For safety, the clutch pedal must be depressed before the car can be started.

The independent front suspension has lower A-arms, strut-mounted coil springs and stabilizer bar tuned for ride smoothness and handling control. Its "negative" scrub geometry provides enhanced straight line and braking stability, even on split-friction surfaces.

Optional 4-speed automatic transaxle has full electronic control of shifting for precise performance. If electronics fails, a fail-safe feature allows some 2nd and 3rd gear function. Shifter can't be taken out of "Park" unless the brake pedal is depressed.

The cowl (between the hood and windshield) is designed to remove rain water pushed down by the wipers. Catchers in the front roof pillars direct rain water over the pillars and roof to help keep the side windows and mirrors clear.

Contour has four dash panel vent registers, side window demisters and rear seat heat ducts. "Positive shut off" feature enables the driver to close all vents simultaneously (rather than closing each one individually) by turning a control on the dash panel.

Every Contour comes equipped with dual air bag supplemental restraint systems, one for the driver and one for the front passenger. The air bag protects against head and chest injuries in certain frontal impacts, but only when used in conjunction with safety belts.

With a 0.31 coefficient of drag, Contour is one of the most aerodynamic cars in its class. Aerodynamics improves economy, maintains handling stability and reduces wind noise. And it does all this without sacrificing roominess.

Solar tinted glass all around reduces heat build-up inside the car when parked and helps the air conditioning system cool the car faster. This is but one of the many comfort features that come standard in every Contour model.

Contour has a 13.9-cubic-foot trunk. The decklid uses gas-assist struts, which take up no space when the lid is closed. The trunk also has a low lift-over height for convenient loading/unloading.

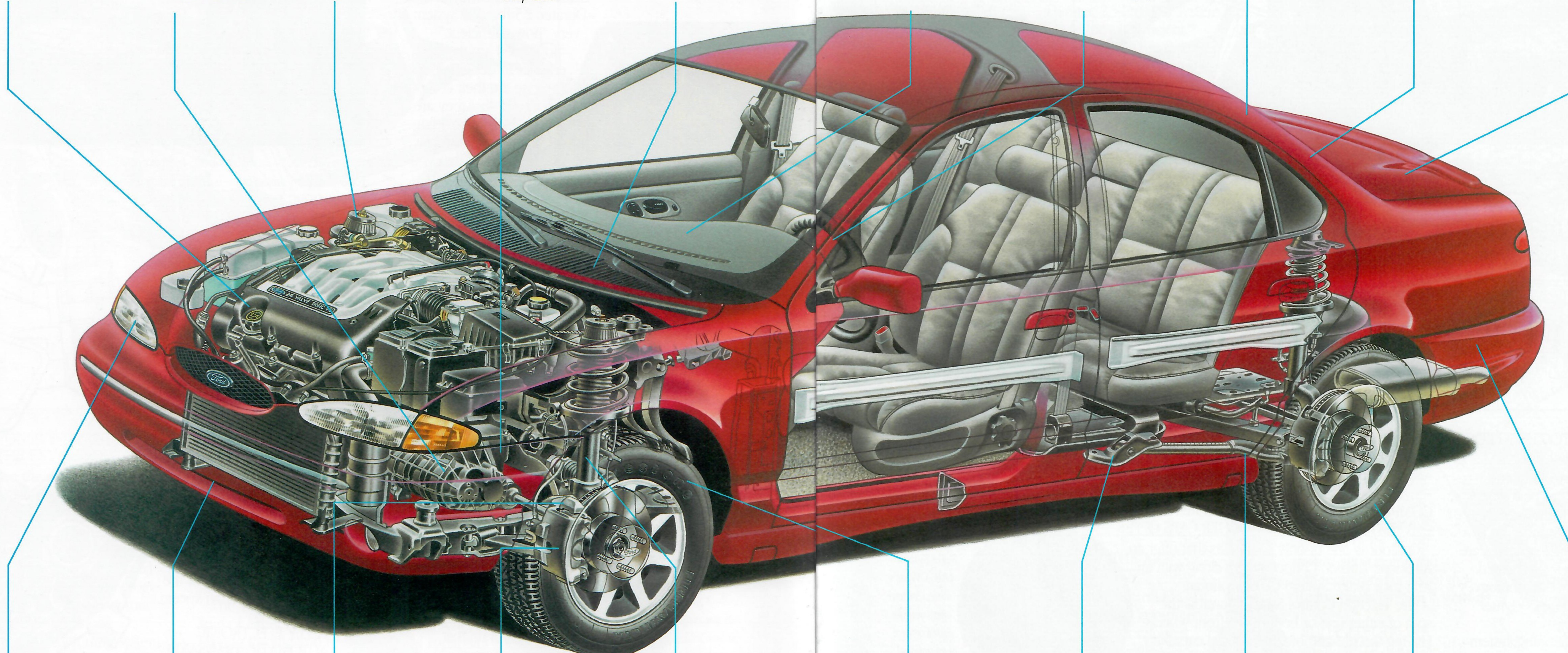

Durable headlamp lenses are designed to be resistant to breakage. Replaceable halogen bulbs are inexpensive and require just a few minutes to install.

The optional electronic All-Speed Traction Control System controls spin of either one or both of the front wheels. With throttle and braking control capability, it enhances control while you're accelerating on a loose or slippery surface.

Power front disc/rear drum brakes (standard in GL and LX) have been engineered to provide responsive stopping action and resistance to fade. The V-6-powered SE (as well as the GL and LX with optional V-6) has rear disc brakes.

The optional Anti-lock Brake System (ABS) keeps the wheels from locking up in a hard braking situation or on a slippery surface by modulating the brakes up to 12 times per second. ABS provides straighter stops and greater steering control.

The front suspension utilizes "hydromount" lower A-arm bushings. Extra hydraulic damping in bushings acts as a mini shock absorber, delivering a smooth ride while helping to maintain enhanced handling capability.

"Rack-and-pinion" steering system, power-assisted, was chosen for its responsiveness, high precision and low-friction characteristics. It has a smooth steering feel at lower speeds and a firm on-center feel at higher speeds.

The rear subframe, which is designed to enhance suspension alignment and control, contributes as well to the outstanding road-holding capability engineered into the suspension system.

The "quadra-link" independent rear suspension with stabilizer bar provides accurate wheel control. Passive rear wheel steering capability produces "toe-in" to counteract the "toe-out" tendency under the forces of cornering and braking.

Contour has a long 106.5" wheelbase (distance between front and rear axles). A long wheelbase allows for more passenger room and enhances ride quality and handling.

5 mile-per-hour bumpers are highly resilient and scuff-resistant. They are designed to protect lamps and other electrical system components from damage during a low-speed impact.

PERFORMANCE

With their advanced designs and electronics, the all-new Zetec 2.0-liter I-4 engine and Duratec 2.5-liter V-6 System are very "power-efficient."

So refined are these engines in design, and so precise are their computer controls, that they are capable of providing the degree of fuel efficiency* that you need while at the same time delivering the level of responsive performance that you desire.

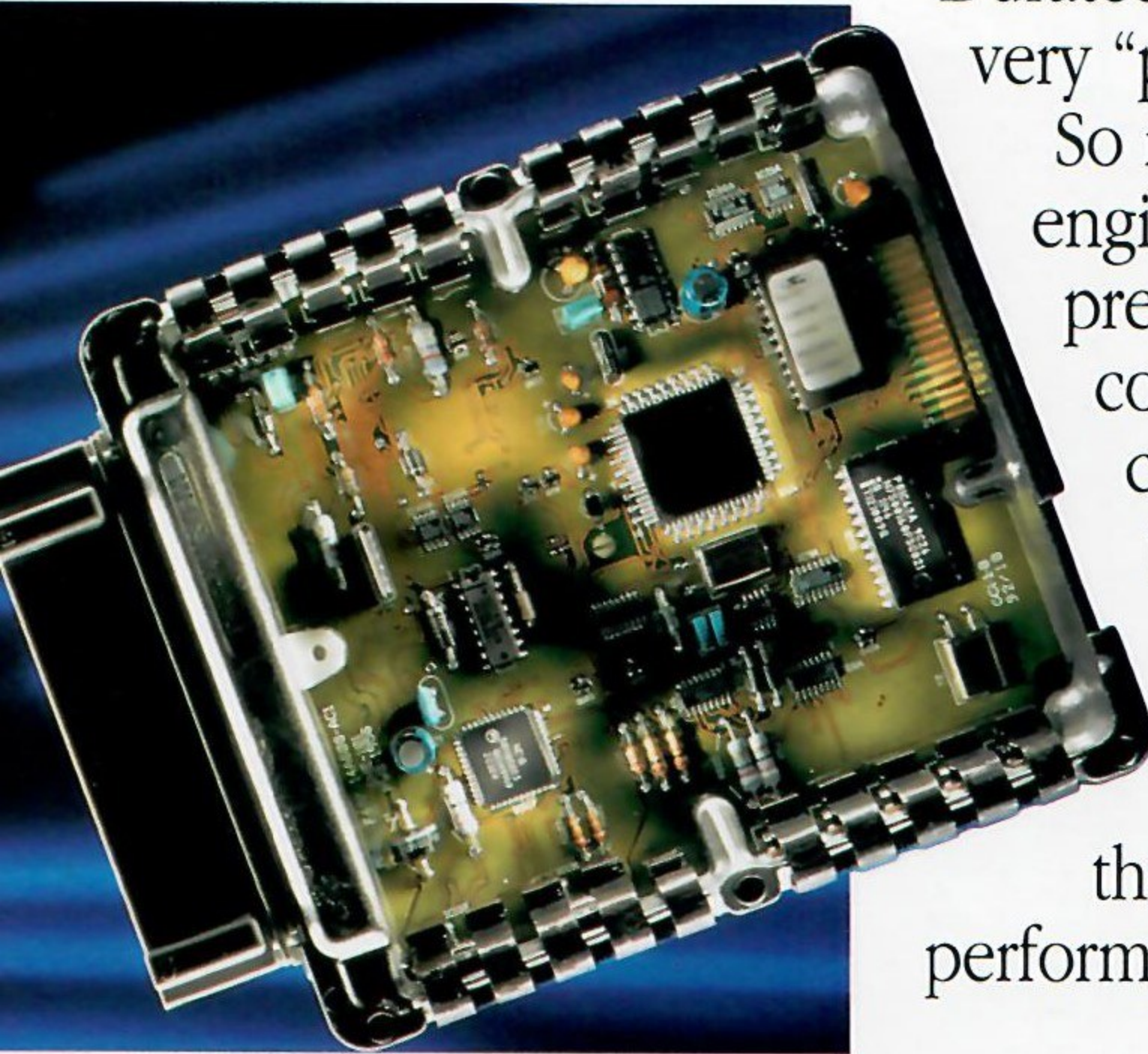

The Electronic Engine Control (EEC-IV) computer is the central intelligence that governs the overall performance of Contour's engines. So powerful is EEC-IV that it can perform up to 1.25 million calculations per second. EEC-IV, in effect, continuously fine-tunes the operations of the powertrain to the requirements of the moment.

MULTI-VALVE, DOHC DESIGN

Freer-breathing four valves per cylinder (versus two) increase the flow of air into and out of each cylinder, delivering higher power output. The valves, each smaller and lighter, permit the use of low-tension springs for a free-revving engine.

Enhancing power output as well are the dual overhead cams: one cam activating the fuel/air intake valves, and the other cam activating the exhaust valves.

STATE-OF-THE-ART ELECTRONICS

Ford's advanced EEC-IV engine control computer system is the brain that controls the engines' performance and efficiency. So powerful is EEC-IV that it receives

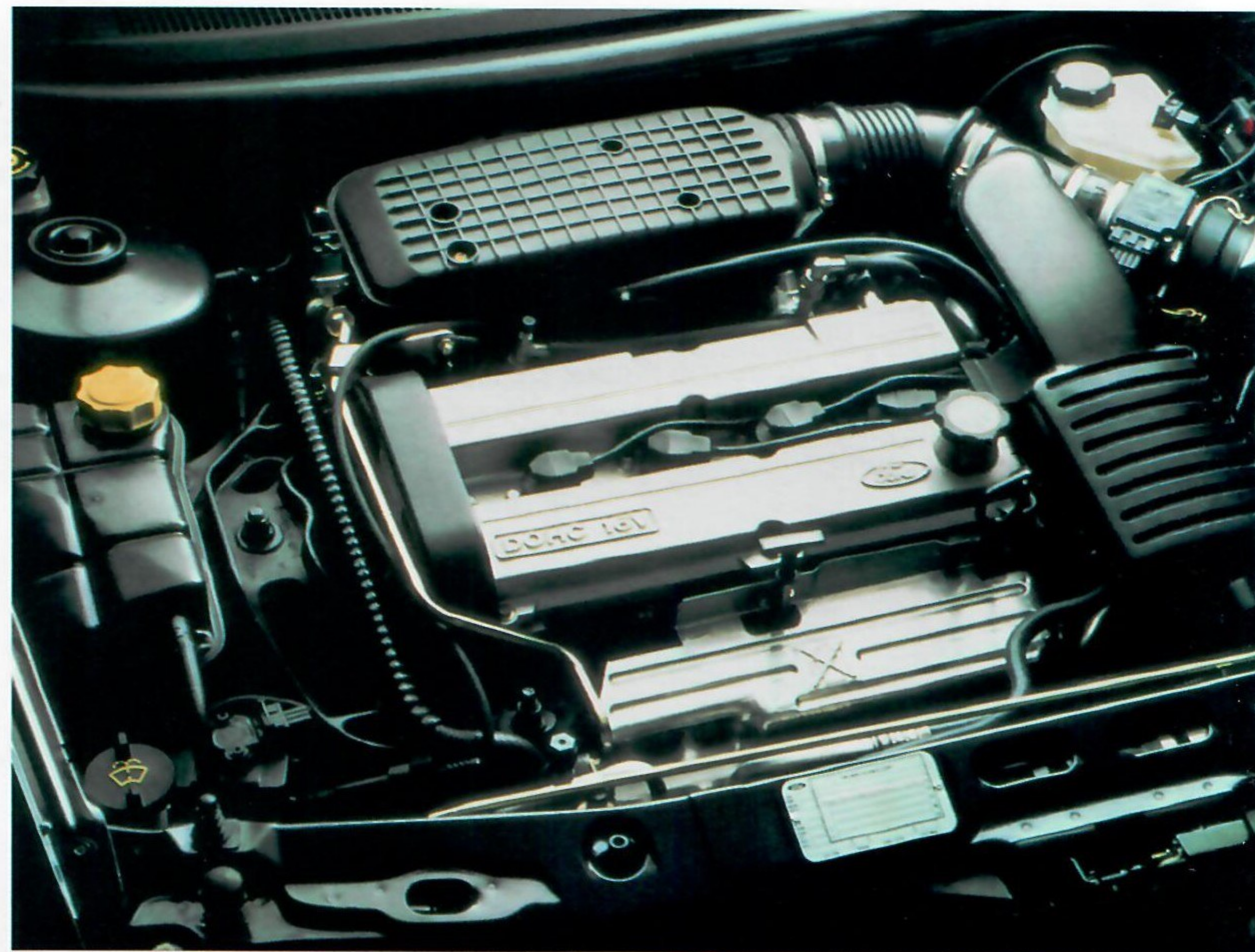

"Power efficiency"—an engine's ability to extract optimum power from every drop of fuel—is a major feature of the 16-valve, DOHC Zetec I-4 engine. Displacing 2.0 liters, or 121 cubic inches, it has a 125 (SAE net) horsepower rating. That's more than one horsepower for every cubic inch of displacement.

and monitors information from nine powertrain functions and can perform up to 1.25 million instructions per second.

Among the many operations EEC-IV governs are the sequential electronic fuel injection system, which releases fuel to each cylinder in "sequence" with the spark firing order; the precision of the mass air-flow sensor; and the split-second accuracy of the distributorless ignition system.

FULLY ELECTRONIC AUTOMATIC TRANSAXLE

EEC-IV also fully governs the functions of the available 4-speed automatic overdrive transaxle.

The Zetec I-4 and Duratec V-6 engines have long-life platinum-tipped spark plugs.



* EPA mileage information was unavailable at press time. See your Ford Dealer for information.

Electronically scheduled shifting compensates for factors like altitude and temperature variations, matching operating conditions to driving requirements more closely. And the computer's "shift logic" prevents unnecessary shifting for smooth and efficient operation.*

If the electronics should fail, the transaxle has a fail-safe feature that provides some function to help ensure that you won't get stranded.

ZETEC 2.0L I-4 ENGINE

Contour's Zetec 2.0-liter I-4 engine is designed to deliver both high fuel economy* and responsive power and torque.

Its 16 valves, dual overhead cam design and state-of-the-art EEC-IV electronic engine

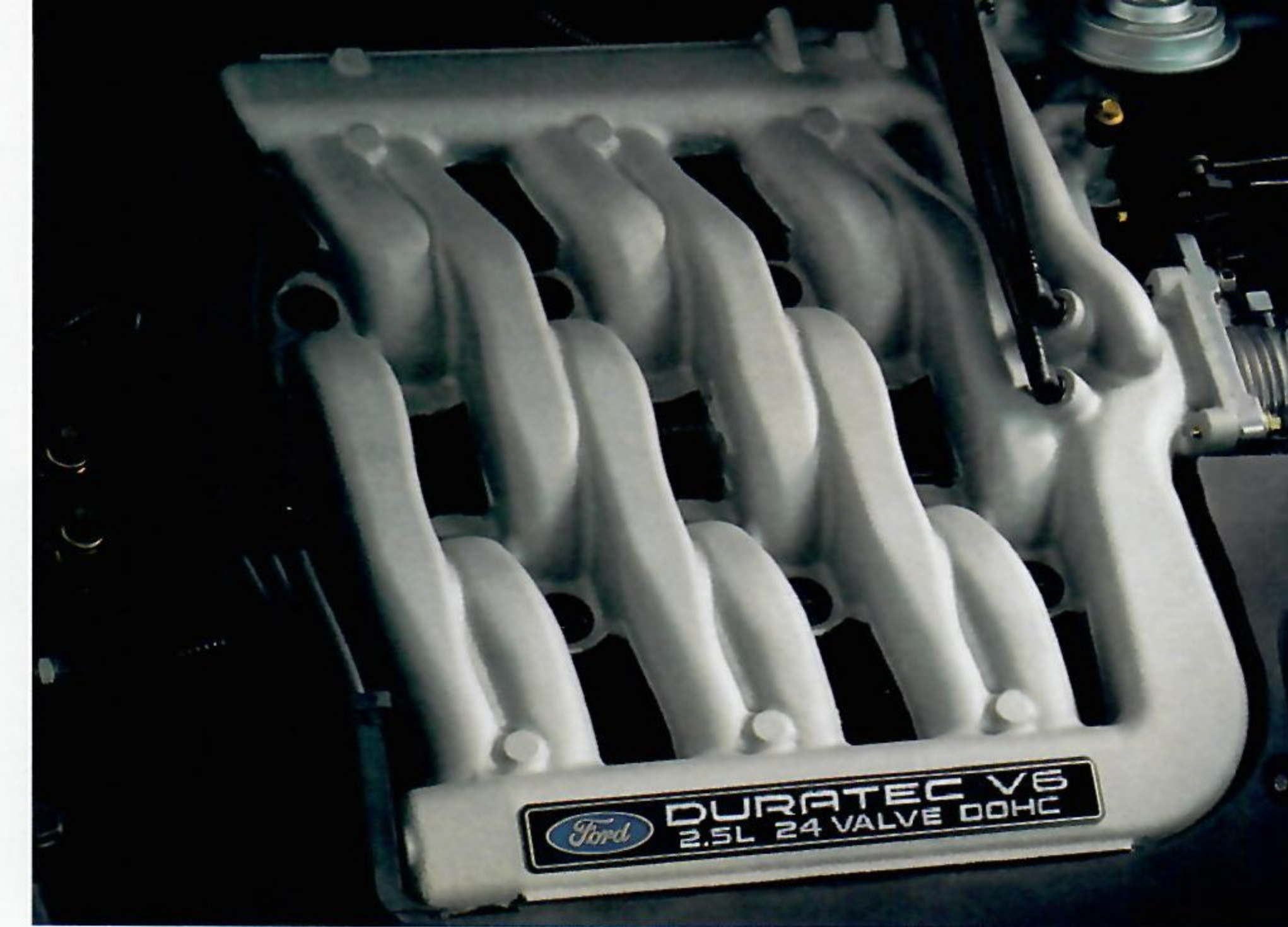

The Duratec V-6 System utilizes Formula One and IndyCar technology in its light yet strong cylinder block. 24 valves and DOHC design contribute to its 170 SAE net horsepower. With just 2.5 liters, or 155 cubic inches, this advanced V-6 puts out more than one horsepower per cubic inch, a potent statement of how power-efficient it is.

controls combine with extensive use of lightweight and low-friction materials to deliver balanced power and efficiency plus low noise and vibration levels.

DURATEC 2.5L V-6 SYSTEM

Formula One and IndyCar technology has gone into creating a cylinder block for the Duratec 2.5-liter V-6 that is light yet extremely strong. This advanced engine has an aluminum block (with cast-iron liners) and heads, tubular steel camshafts, a fully counterweighted forged steel crankshaft, and a silent chain-driven cam drive. What's more, the Duratec V-6 requires no scheduled maintenance other than routine fluid and filter changes for the first 100,000 miles.

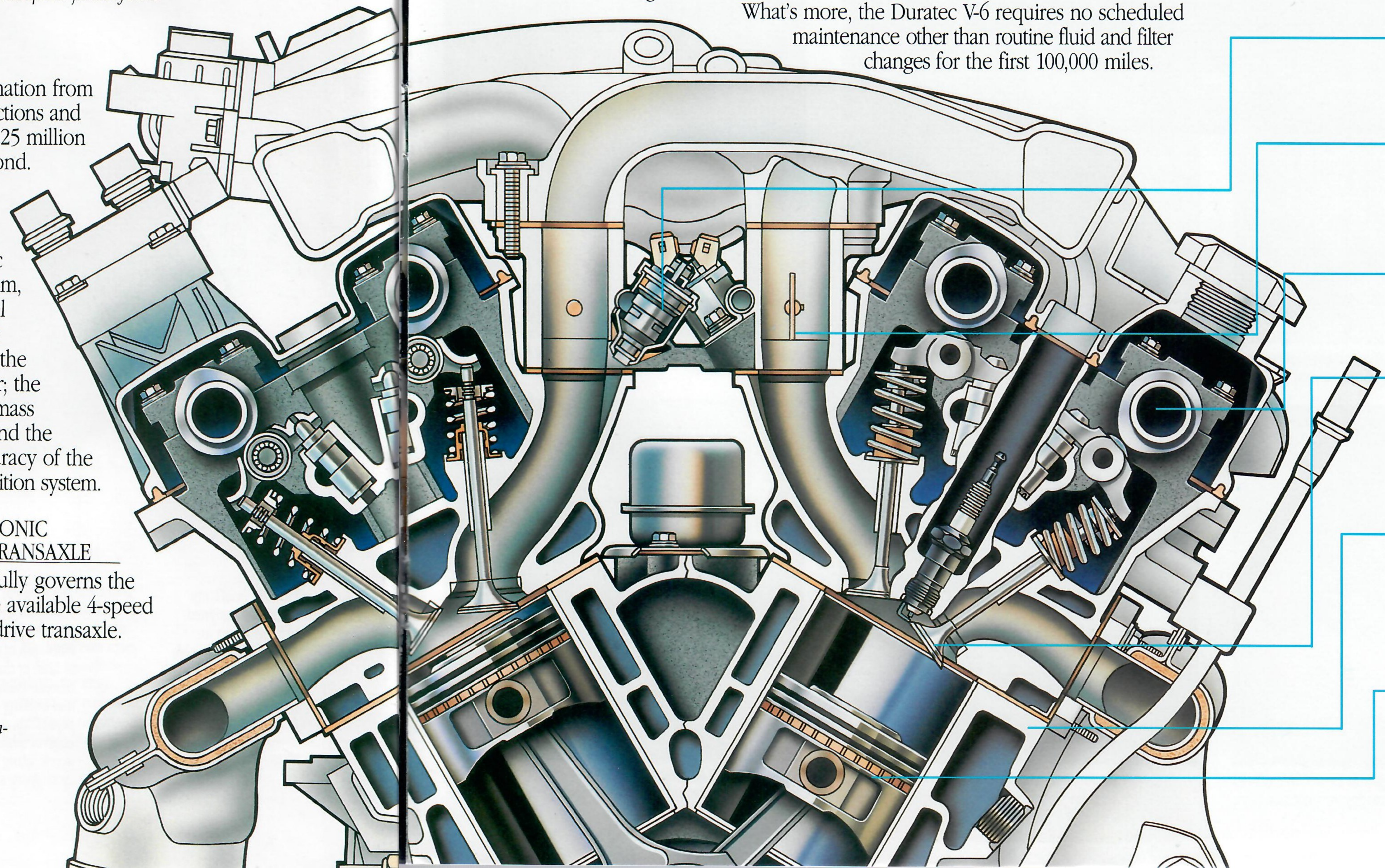

The Duratec 2.5-liter V-6 has many features contributing to its power, efficiency and durability, including:

- Sequential electronic injection with mass air-flow sensor and knock sensor
- Variable induction with dual tuned runners for responsive low-end torque and excellent performance
- Light tubular steel camshafts with forged steel lobes for added performance
- 4 valves per cylinder and dual overhead cams (one activating the intake valves, the other the exhaust valves) for high power output
- An aluminum block (with cast-iron liners) and cylinder heads for enhanced performance plus reduced noise and vibration
- Patented low-friction material coating on pistons and skirts for higher economy and reduced noise and vibration

FEATURES

You can spend a lot of time discovering the numerous comforts and conveniences that make up the Contour equipment list. Especially noteworthy are the small details, the "nice touches" that make for a more pleasant trip. Featured here are just a few.

COURTESIES TO LIGHT UP YOUR TRIP

If you're like most people, you probably drive at night almost as much as you do during the daytime. So when it comes to courtesy lights, the more the better. In

Contour, there are many: Lighted switches and heater controls, including the rotary master light switch, and glove box light (standard). Lighted visor mirrors (standard in LX and SE), trunk and engine bay lights, front map reading lamp, front footwell illumination, illuminated entry system and lighted inside door handles (with the available Light Group). Available power window and door lock controls are also lighted.

PLENTY OF PLACES TO PUT THINGS

Contour is equipped also to satisfy those for whom storage space never seems to be quite adequate. There's a storage bin in the front door trim panels (all models) and one as well in the front seat side valence panel (in LX and SE). The floor console in GL includes cassette storage and cupholders. The full-length console that's standard in LX and SE (available in GL) also includes an armrest/storage bin with cassette/CD slots.

AND MANY OTHER CONVENIENCES

Versatile folding rear seat backs that allow longer items like skis to go into the trunk (LX and SE). Remote-control decklid and fuel door releases. Available "heated" outside mirrors with rear window defroster. You'll find these, too, and many others in Contour, a "customer-driven" car from Ford.



Contour has a 13.9-cubic-foot trunk. The decklid uses gas-assist struts, which take up no space when the lid is closed. The trunk also has a low lift-over height for convenient loading and unloading.



Illuminated interior door handles are among the many features included in the available Light Group.



Available power windows and door locks also feature illuminated controls.



Visibility while driving at night is also enhanced by illuminated controls on the instrument panel.



Cupholders (one with the 5-speed manual transaxle) are part of the full floor console in all models.

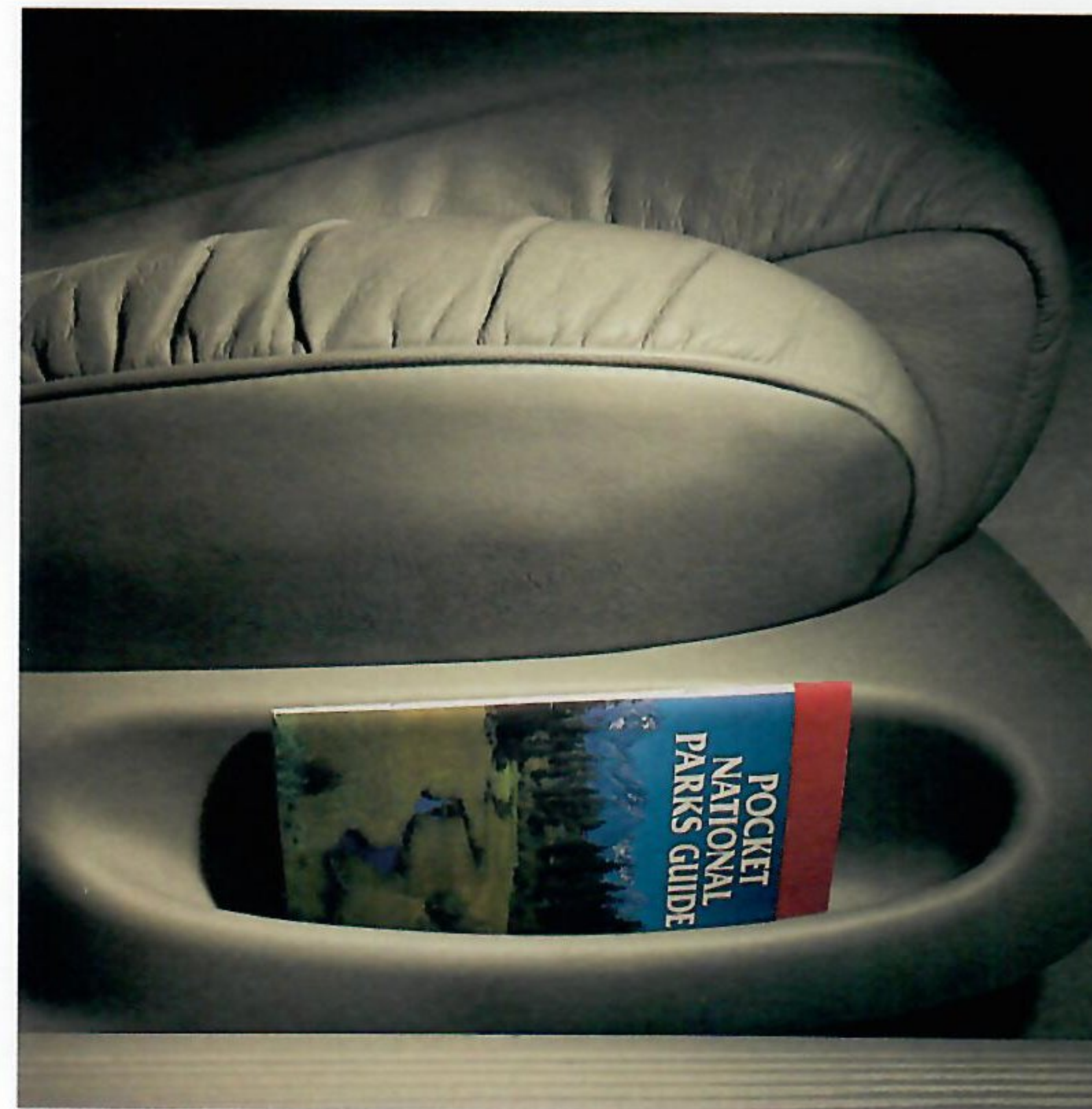

Front seat side valence panel storage bins are standard in Contour LX and SE.



In the full-length center floor console in Contour LX and SE are slots for tape cassettes and compact discs.

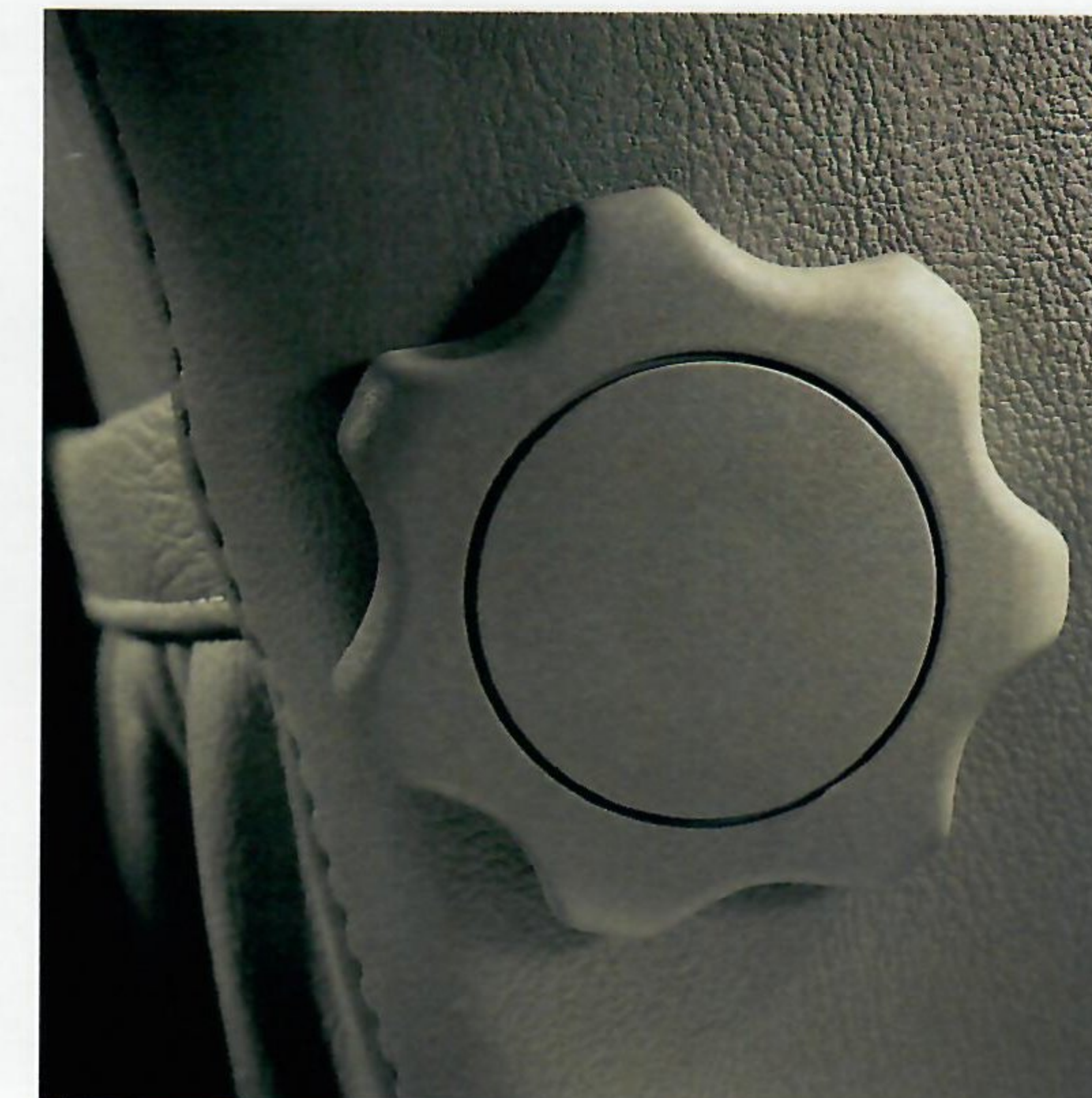

Driver seat lumbar adjustment is a standard feature in Contour LX and SE (passenger side also in SE).



LX and SE also provide fold-down rear seat backs for added trunk space. Releases are in the trunk for security.



Every Contour model provides the convenience of remote-control decklid and fuel door releases.



Standard in all Contour models are tilt/height 4-way adjustable front seat head restraints.



Dual remote-control outside mirrors are standard. "Heated" mirrors are in all Preferred Equipment Packages.



Heat is distributed through vents on the instrument panel and also through rear seat area ducts.

OPTIONS & SPECIFICATIONS

There's seemingly no end to the ways you can personalize your Contour GL, LX or SE, to tailor it to your particular style of driving enjoyment.

There is a fine selection of high-quality, high-performing stereo sound systems—from the standard electronic AM/FM radio (with cassette player included in Contour LX and SE) on up to the AM/FM system with compact disc player and premium sound system featuring an upgraded amplifier.

Other options include the power moonroof, power windows (with "one-touch down" driver-side window plus controls which allow the driver to lock the rear windows) and the 10-way power driver's seat.

There are a number of outstanding performance options you'll also want to consider:

The high-excitement, low-maintenance Duratec 2.5-liter V-6 System. The fully electronic 4-speed automatic overdrive transaxle. Computer-controlled Anti-lock Brake System (ABS). And the electronic All-Speed Traction Control System (along with ABS) which only a few other cars make available.

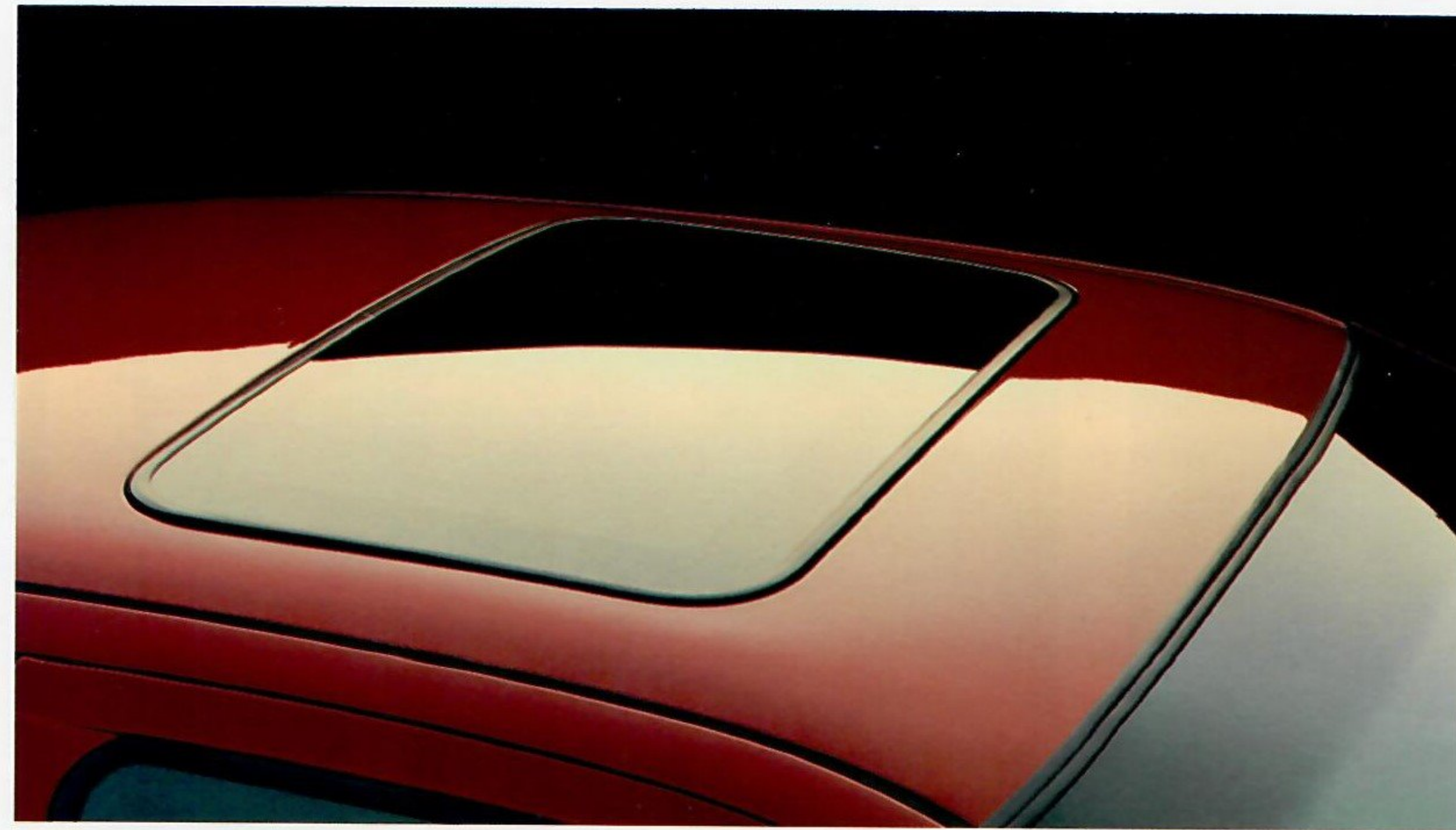

Let in more sunshine and fresh air with the optional power moonroof. Includes a manually operated privacy shade.

There's an electronic AM/FM stereo radio available with CD player and premium sound system featuring an upgraded amplifier.

Contour SE offers an optional 6-way power driver's seat with forward/back, up/down and tilt forward/back power adjustment, plus manual lumbar support and seat back recliner. In Contour LX, the lumbar support and seat back recliner are power-adjustable, making this a 10-way power seat.

For added security, Contour offers an optional remote keyless entry system. Includes two transmitters.



Left to right: 14" wheel cover (std. on GL); 14" luxury wheel cover (std. on LX); 14" cast aluminum wheel (opt. on GL and LX); 15" cast aluminum wheel (std. on SE); 7-spoke cast aluminum wheel (opt. on SE—see your dealer for availability).

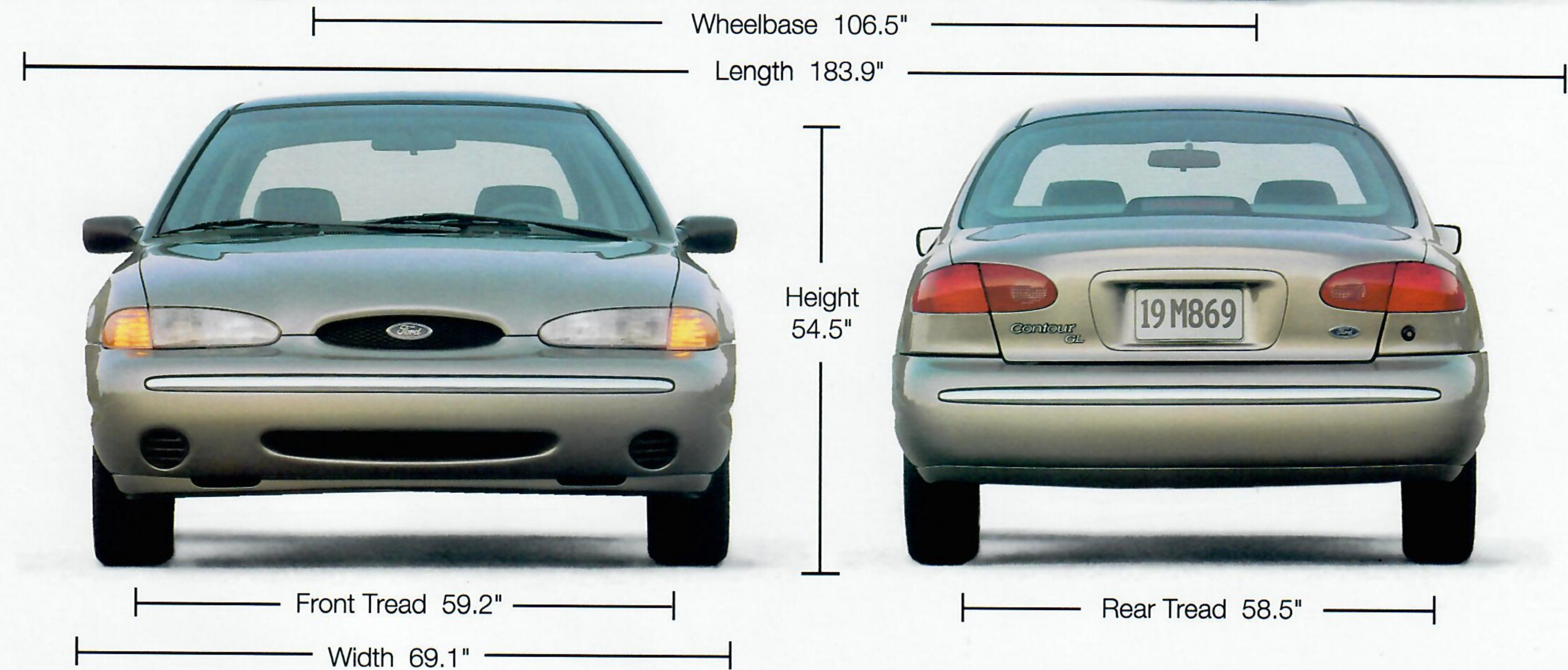

SPECIFICATIONS

Drivetrain:	Front-wheel drive
Engines:	Zetec 2.0-liter 16-valve, DOHC I-4 (std. GL, LX) Duratec 2.5-liter 24-valve, DOHC V-6 (std. SE; opt. GL, LX)
Induction system:	Sequential electronic fuel injection/EEC-IV computer
Compression ratio:	9.6:1 (Zetec 2.0-liter I-4); 9.7:1 (Duratec 2.5-liter V-6)
Transaxles:	Std. 5-speed manual overdrive transaxle Opt. electronic 4-speed automatic overdrive transaxle
Horsepower, SAE net:	125 @ 5500 rpm (Zetec 2.0-liter I-4) 170 @ 6250 rpm (Duratec 2.5-liter V-6)
Torque, SAE net:	130 lbs.-ft. @ 4000 rpm (Zetec 2.0-liter I-4) 165 lbs.-ft. @ 4250 rpm (Duratec 2.5-liter V-6)
Battery:	55 AH maintenance-free
Alternator:	130 amps
Body:	Unitized construction with separate front rubber-mounted subframe
Front suspension:	Independent strut-type with lower A-arms, strut-mounted coil springs and stabilizer bar; sport tuning in SE
Rear suspension:	Independent quadra-link rear system with stabilizer bar; sport tuning in SE
Steering:	Rack-and-pinion, power assisted
Brakes:	Std. power front disc/rear drum (GL, LX) Std. power 4-wheel disc (SE) Opt. 4-wheel anti-lock system
Fuel tank capacity:	14.5 gallons
Tires:	185/70R14S BSW all-season (GL, LX) 195/65R14 BSW all-season (GL and LX with opt. Duratec 2.5-liter V-6) 205/60R15 BSW all-season (SE)

DIMENSIONS

	4-Door
Wheelbase	106.5"
Length	183.9"
Height	54.5"
Width	69.1"
Front tread	59.2"
Rear tread	58.5"
Front head room	39.0"
Rear head room	36.7"
Front leg room	42.4"
Rear leg room	34.3"
Front shoulder room	53.9"
Rear shoulder room	53.3"
Front hip room	50.7"
Rear hip room	45.5"
Trunk capacity (cu. ft.)	13.9
Passenger capacity	5

THE OWNERSHIP EXPERIENCE



We've gone to great lengths to make the experience of driving a new Ford Contour enjoyable. The experience of ownership, too.

We stand behind your car with our 3-year/36,000-mile bumper-to-bumper limited warranty. And we look after your security with our no-cost Roadside Assistance Program. You can expect nothing less from a "customer-driven" company.

ROADSIDE ASSISTANCE PROGRAM

Every new Ford includes the assurance of an emergency no-cost Roadside Assistance Program provided by Ford Auto Club, Inc. during

the 3-year/36,000-mile bumper-to-bumper warranty period. Help is just a toll-free phone call away, 24 hours a day, anywhere in the 50 United States, should you need any towing assistance, fuel delivery, tire change, a jump start, or even help when you're locked out of your car. Ask your Ford Dealer for complete details on the Ford Roadside Assistance Program and also for a copy of the limited warranty.

BUMPER-TO-BUMPER COVERAGE

The 36-month/36,000-mile bumper-to-bumper coverage of Ford's new vehicle limited warranty covers

the complete vehicle (except tires, battery, service adjustments and other items covered under separate provisions) against defects in factory-supplied materials or workmanship. For complete information, see your Ford Dealer.

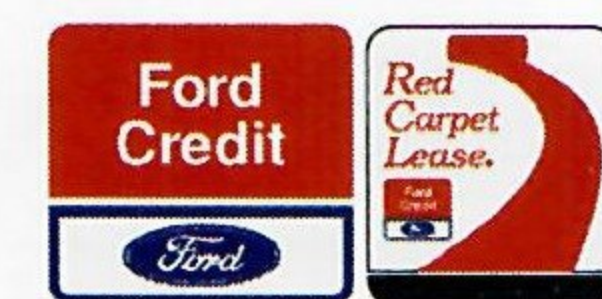

Ford Credit is a full service company that makes a wide variety of financing and leasing programs available to qualified buyers through the Ford Dealer of your choice.

Through Ford Credit's financing or Red Carpet leasing, arrangements suited to your special needs can be

made quickly and conveniently right at the dealership.

Ask your Ford Dealer for the facts on any of Ford Credit's financing or lease plans.

FORD CITIBANK CREDIT CARD

Using your Ford Citibank Visa® or MasterCard® could earn you hundreds, even thousands of dollars from Ford toward the purchase or lease of a new Ford, Lincoln or Mercury product.

To apply or get more information, call 1-800-374-7777. Or visit a Ford or Lincoln-Mercury Dealer, or a branch office of Citibank.



Optional Ford Extended Service

Plans can cover major components on new Ford products for longer than the basic warranty. Your dealer has full details.

DEALER-INSTALLED ACCESSORIES

The enjoyment of owning a new car begins when you're selecting colors and features. Along with the items on pages 28-29, there are Ford-brand accessories available at your dealer. They meet or exceed our strict specifications; are designed to complement the style and quality of your Ford-built vehicle.

Ford Contour, like all Ford cars, comes with a 3-year/36,000-mile bumper-to-bumper limited warranty plus the no-cost Roadside Assistance Program. See your Ford Dealer for complete information on these and many other ownership service programs.

CONTOUR EQUIPMENT

EXTERIOR FEATURES

	GL	LX	SE
Flush headlamps with replaceable halogen bulbs	S	S	S
16-mph color-keyed bumpers	S	S	S
Flush color-keyed door handles	S	S	S
Polar tinted semi-flush glass	S	S	S
Tripleless door construction with water management system	S	S	S
Remote-control mirrors with black finish	S	-	-
Power mirrors with body-color finish	P	S	S
Color-keyed bodyside moldings	S	S	S
Fog lamps	-	S	S
Color-keyed spoiler	-	-	S

SAFETY AND SECURITY

"Safety cell" body structure with high-tensile steel door beams and cross-car beam	S	S	S
Dual front air bag supplemental restraint systems	S	S	S
Manual lap/shoulder belts for front/rear outboard positions	S	S	S
Lap belt for rear center seating position	S	S	S
Shoulder safety belt height adjusters	S	S	S
Tilt/height 4-way adjustable head restraints	S	S	S
Clutch interlock at start-up with manual transaxle; Brake shift interlock with optional automatic transaxle	S	S	S
Fuel tank mounted forward of rear suspension	S	S	S
Shielded interior door locks	S	S	S
Child-proof rear door locks	S	S	S
Ford Roadside Assistance Program	S	S	S
Anti-lock Brake System (ABS)	O	O	O
Anti-Speed Traction Control System with ABS	O	O	O
Remote keyless entry system	O	O	O

COMFORT AND CONVENIENCE

MicronAir® Filtration System	S	S	S
Air conditioning	P	P	P
Center floor console with cassette storage, cupholders and rear ashtray	S	-	-
Full center floor console with pop-up cupholders, plus armrest/storage bin with cassette/CD slots	P	S	S
Soft-feel driver-oriented instrument panel with side window demisters and four registers	S	S	S
Analog gauges and warning lights	S	S	S
Tachometer (included with optional V-6 engine in GL)	O	S	S
Driver's left footrest	S	S	S
Seat valence panel storage bins	-	S	S
Driver seat lumbar adjustment (passenger seat also in SE)	-	S	S
Front passenger and two rear grab handles (front only in GL)	S	S	S
Courtesy lights: illuminated switches and heater controls, rotary master light switch, glove box, front heater-mounted interior light with door courtesy switches	S	S	S
Variable-timed interval windshield wipers	S	S	S
Remote-control decklid and fuel door releases	S	S	S
Driver and passenger visor mirrors (lighted in LX and SE)	S	S	S
Front door trim panel storage bins	S	S	S

	GL	LX	SE
Leather-wrapped steering wheel (available in LX with optional leather seating surfaces)	-	O	S
Electronic digital clock	S	S	S
Rear seat compartment heat ducts	S	S	S
Light Group: illuminated sun visors; rear door courtesy light switches; load compartment light; engine compartment light; front map reading light; front footwell illumination; illuminated entry system; and illuminated door handles	P	P	P
Power windows (with "one touch down" feature on the driver's window)	P	P	P
Power door locks	P	P	P
Electronic 4-speed automatic overdrive transaxle	O	O	O
Power moonroof	O	O	O
Speed control	P	P	P
Rear window defroster	P	P	P
Carpeted front/rear floor mats	O	O	O

SEATING

Cloth reclining bucket seats	S	-	-
Luxury cloth reclining bucket seats	-	S	-
Sport cloth reclining bucket seats	-	-	S
Leather seating surfaces	-	O	O
10-way power driver's seat: power adjustment up/down, forward/back and tilt forward/back; plus power-adjustable lumbar support and seat back recliner	-	O	-
6-way power driver's seat: power adjustment up/down, forward/back and tilt forward/back; plus manually adjustable lumbar support and seat back recliner	-	-	O
3-passenger rear bench seat	S	-	-
3-passenger rear bench seat with 60/40 split fold-down carpeted seat backs (releases located in trunk for security)	-	S	S

SOUND SYSTEMS

Electronic AM/FM stereo radio	S	-	-
Electronic AM/FM stereo radio with cassette player	P	S	S
Premium sound audio system with AM/FM stereo radio with cassette player	O	O	O
Premium sound audio system with AM/FM stereo compact disc radio	O	O	O

WHEELS AND TIRES

14" wheel covers	S	-	-
14" luxury wheel covers	-	S	-
14" cast aluminum wheels	O	O	-
15" cast aluminum wheels	-	-	S
15" 7-spoke cast aluminum wheels (see your dealer for availability)	-	-	O
185/70R14S BSW all-season tires	S	S	-
195/65R14S BSW all-season tires (with V-6 engine)	O	O	-
205/60R15 BSW all-season tires	-	-	S

S = Standard feature O = Optional feature P = Preferred Equipment Package feature



Champagne Clearcoat Metallic

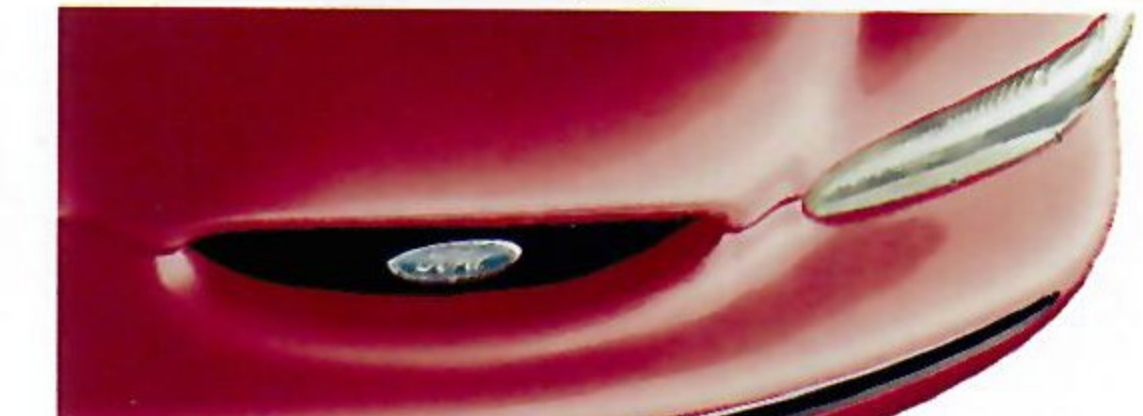

Electric Red Clearcoat Metallic



Coral Mist Clearcoat Metallic



Midnight Red Clearcoat Metallic

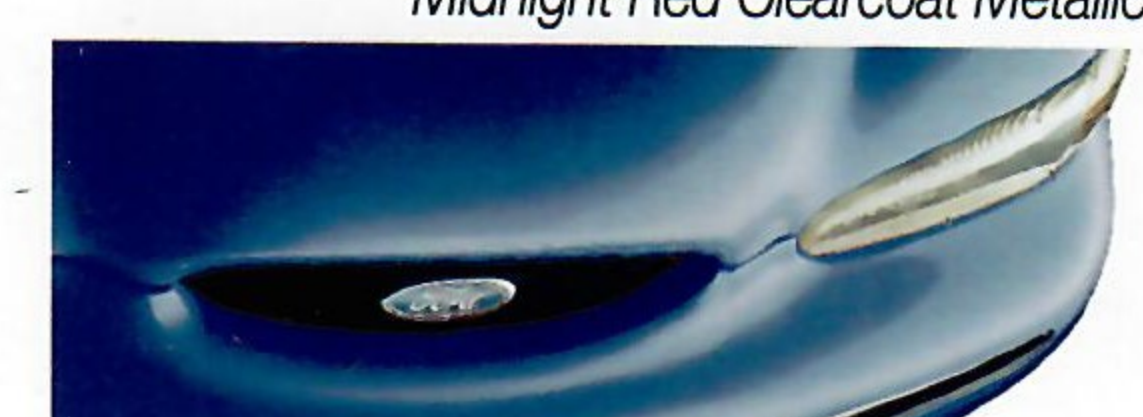

Moonlight Blue Clearcoat Metallic

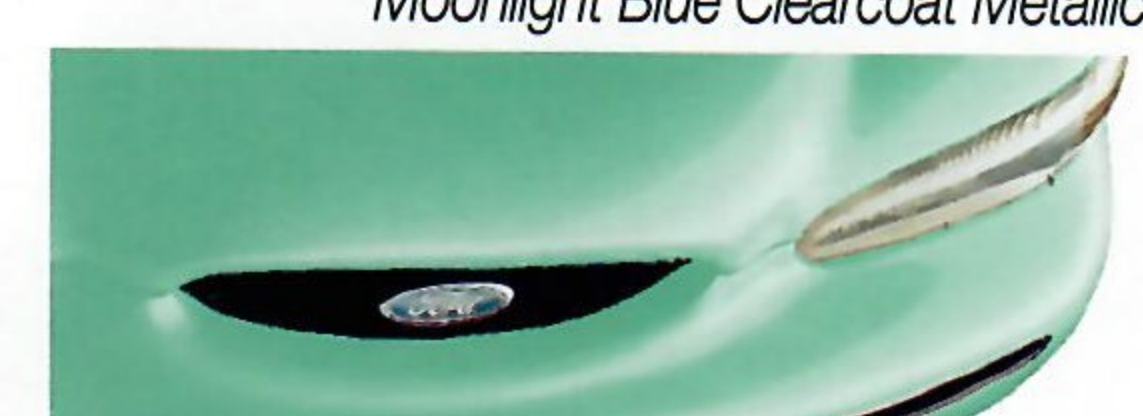

Tobago Green Clearcoat Metallic



Teal Clearcoat Metallic

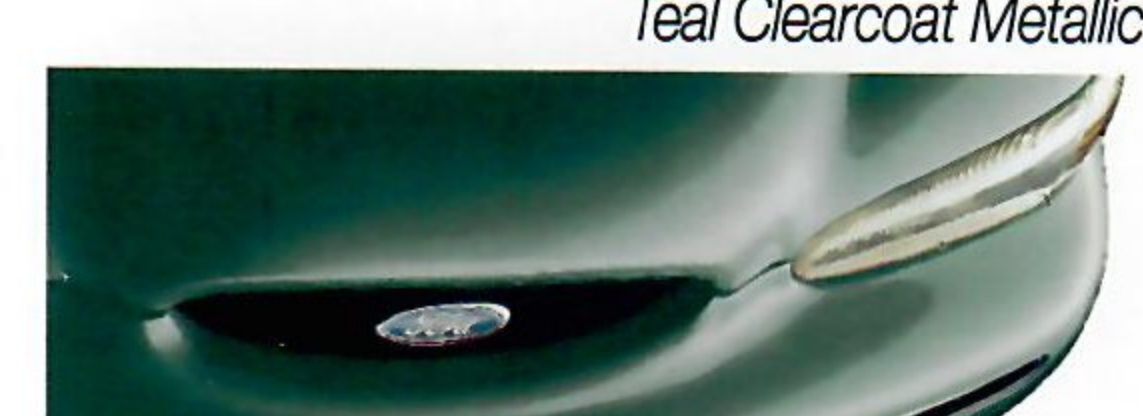

Medium Willow Green Clearcoat Metallic

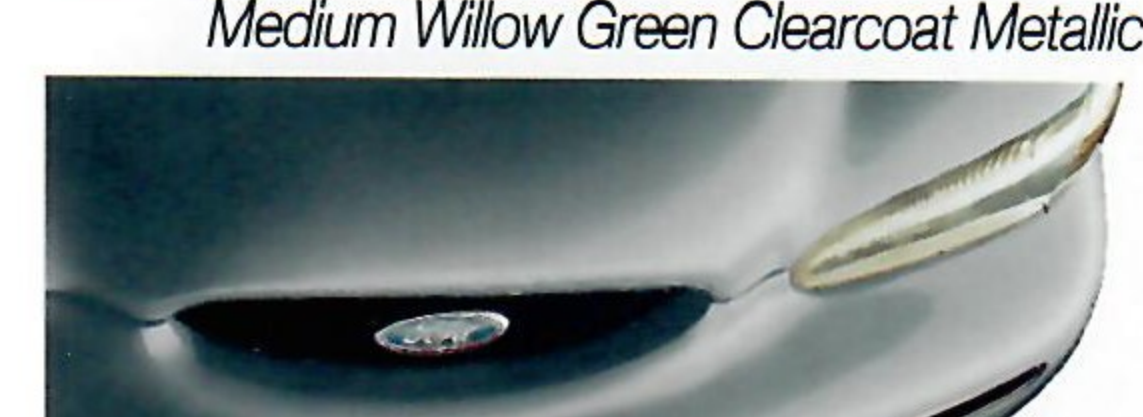

Charcoal Grey Clearcoat Metallic



Vibrant White Clearcoat



Portofino Blue Clearcoat Metallic

PREFERRED EQUIPMENT PACKAGES & COLORS

PREFERRED EQUIPMENT PACKAGES

	GL			LX	
	235A	236A	240A	237A	238A
GROUP 1	●	●	●	S	S
Full-length center floor console					
Electronic AM/FM stereo radio/cassette player					
GROUP 2	●	●	●	●	●
Air conditioning					
"Heated" mirrors and rear window defroster					
Body-colored power mirrors (standard on LX and SE)					
GROUP 3	○	●	●	●	●
Light group: illuminated sun visors; rear door courtesy light switches; load compartment light; engine compartment light; front map reading light; front footwell illumination; illuminated entry system; illuminated door handles					
Power door locks					
Speed control	○	●	●	●	●
Power windows		○	●	●	●
Duratec V-6 System: 2.5-liter V-6 engine, 4-wheel power disc brakes, 195/65R14 tires (GL and LX), 205/60R15 tires (SE), plus performance-tuned steering and suspension systems			●		●

● Preferred Equipment Package feature S = Standard feature ○ = Optional feature

EXTERIOR PAINT & INTERIOR TRIM COLORS

EXTERIOR PAINT COLORS	Atlantis Blue	INTERIOR TRIM COLORS		
CONTOUR GL & LX		Opal Grey	Pumice	Ruby
Champagne Clearcoat Metallic	●		●	●
Electric Red Clearcoat Metallic		●	●	●
Coral Mist Clearcoat Metallic		●	●	●
Midnight Red Clearcoat Metallic		●	●	●
Moonlight Blue Clearcoat Metallic	●	●		
Tobago Green Clearcoat Metallic		●	●	
Teal Clearcoat Metallic		●	●	
Medium Willow Green Clearcoat Metallic		●	●	
Charcoal Grey Clearcoat Metallic	●	●		●
Vibrant White Clearcoat	●	●	●	●
Portofino Blue Clearcoat Metallic	●	●		
CONTOUR SE				
Champagne Clearcoat Metallic	●		●	●
Electric Red Clearcoat Metallic		●	●	●
Midnight Red Clearcoat Metallic		●	●	●
Moonlight Blue Clearcoat Metallic	●	●		
Tobago Green Clearcoat Metallic		●	●	
Teal Clearcoat Metallic		●	●	

PRODUCT CHANGES

Following publication of this catalog, certain changes in standard equipment, options, prices and the like, or product delays, may have occurred that would not be included. Your Ford Dealer is your best source for up-to-date information. Ford Division reserves the right to change product specifications at any time without incurring obligations.

OPTIONS AVAILABILITY

Options shown or described are available at extra cost and may be offered only in combination with other options or subject to additional ordering requirements or limitations.



Printed on recycled paper
10% post-consumer waste



242-Ann. Litho in U.S.A. 8/94