

# FORD '80 COURIER

Tough  
Ford  
Courier





# Tough '82 Ford Courier





# Here are the reasons Ford Courier is so popular.

Spunky Courier is a versatile performer for on-the-job toughness and all kinds of recreational fun. And whatever Courier does, it does with economy. Gas mileage figures for the '82 Courier are 38 est. hwy. and 27 EPA est. mpg.\* Ratings like this have kept Courier a mileage leader among the best-selling compacts for the past five years, unsurpassed by Datsun, Toyota and Chevy Luv!† And Courier offers an optional 5-speed manual transmission with an overdrive gear that greatly reduces engine RPM for extra efficiency.

All '82 Couriers feature state-of-the-art technology like the new energy-absorbing steering column. Stalk-mounted controls are standard, and this year the steering column locks for greater security.

For bulky payloads, Courier offers an optional 7-ft. box which gives you an added foot of length over the standard box. There are two engine choices; the standard 2.0L or the optional 2.3L. And all Couriers are covered by Ford's Limited Corrosion Perforation Warranty for up to three years (see back cover).

For specialized applications, you may also choose Courier's Chassis-Cab model with either short or long wheelbase, which lets you add a custom body of your choice\*\* (not available in California).

\*Projected Ford Division estimates for comparison. Your actual mileage may differ depending on speed, distance and weather. Actual highway mileage will probably be lower. See your Ford Dealer for his 1982 EPA Gas Mileage Guide.

†Diesels excluded.

\*\*Subject to the constraints outlined in the 1982 Courier Incomplete Vehicle Manual.



## '82 Ford Courier ...on the inside and outside...

You can have your Courier plain and simple, luxurious or sporty with a choice of four distinctive trim levels: standard Courier, Courier XLT, Courier with Sport Group, or Free Wheeling Courier.

As you'll see by reading over the list on page 6, the standard Courier comes very well equipped. The power train is the 2.0L OHC engine with 4-speed manual transmission. Power front disc brakes and independent front suspension are standard. Courier's rugged ladder-type frame supports the roomy 6-ft. cargo box. Inside, the pleated vinyl seat trim is available in Black, Blue or Tan.

XLT, the top-of-the-line Courier, offers rich interior and exterior appointments that add a touch of luxury. The interior features Herringbone cloth seat trim in Tan or Blue with contrasting accent stripe on the seat back and door trim. The outside features include bright accents and deluxe wheel covers.

The Sport Group option presents another kind of Courier with its striking black and white plaid cloth seat trim and black trim touches. Temperature gauge, ammeter and bright argent instrument panel appliques are other highlights (see pages 6 and 7 for full package content).

And the Free Wheeling Package gives your Courier youthful, sporty looks and appeal. It includes black painted GT bar, front push bar, tricolor accent tape stripe and deluxe wheel covers.

Whichever is your choice, you'll find that Courier is one tough pickup for the young and young at heart.

Left: Free Wheeling Courier in Yellow. Shown with owner-added tires and aluminum wheels.

Right (top to bottom): XLT interior in Tan; Courier XLT in Dark Red; Standard Courier in Light Blue; Standard interior in Blue.





# Ford Courier Trim Content

	Courier	XLT
<b>INTERIOR</b>		
Door trim	color-keyed vinyl door trim panel	woodtone upper, pleated vinyl with contrasting accent stripe, carpeted lower with bright molding
Floor	charcoal-colored floor mat	color-keyed 14-oz. cut-pile carpeting
Headliner	full-vinyl color-keyed	full-vinyl color-keyed
Inside hood release	STD	STD
Instrument panel	padded, with bright argent cluster applique	padded, with woodtone cluster applique
AM pushbutton radio (may be deleted for credit)	STD	STD
Seat	bench seat with hinged back in pleated vinyl	bench seat in deluxe pleated cloth trim with contrasting accent stripe
Seat belts	black	color-keyed
Steering wheel	black 2-spoke	color-keyed
Energy-absorbing steering column with locking feature	STD	STD
Column-mounted stalk controls for daytime passing, high beams, emergency flasher, headlights, turn signal, electric windshield washer and wiper and ignition switch	STD	STD
Door-mounted courtesy light switch	NA	STD
Ammeter and temperature gauges	OPT**	STD
Glove box lock	NA	STD
Ashtray, glove box and underhood lights	NA	STD
Inside mirror	rearview	day/night rearview
<b>EXTERIOR</b>		
Bumper	bright front	bright front
Wheels	bright hub caps	deluxe wheel covers
Front side marker lights	STD	STD
Wraparound taillights	STD	STD
LH mirror	STD	STD
Cargo tie-down hooks	STD	STD
Bright moldings	OPT**	bodyside with vinyl insert, drip rail, grille surround, rear window, taillamp surround, wheelip, windshield

\*With Sport Group only. STD = Standard OPT = Optional NA = Not available  
 \*\*See Exterior Decor Group for available bright moldings.

## Specifications

Engine	Axle, Rear (rating)	2,530 lb.
Type	Ratio	3.3 to 1
Displacement	(with opt. 2.3L)	3.6 to 1
Compression Ratio	Frame	Ladder type, box section
Fuel Tank	Tires, Five Truck-Type	6.00 x 14 C WSW (tubeless)
SWB — 56 liter (14.8 gal.)		
LWB — 66 liter (17.4 gal.)		
Electrical System	<b>FORD COURIER PICKUP LOAD CHART</b>	
Battery	Suspension	Std. Opt.
Alternator	Payload*	1,400 lb. 900 lb.
35 amp.	GVWR	4,100 lb. 3,600 lb.
Transmission	Max. Trailer Wt.	2,000 lb.† NR
4-speed manual	Gross Combined Wt.	5,000 lb.† NR
Clutch Diameter	Camper Capability	YES NO
8.46 in. (hydraulic actuation)		
Power Brakes		
Disc front, drum rear		
Steering		
Variable ratio		
Turning Diameter		
(curb to curb)		
SWB — 39.4 ft.		
LWB — 41.3 ft.		
Suspension		
Front		
Independent type with coil springs and stabilizer bar		
Rear		
6-leaf progressive-rate springs		
Shock Absorbers		
(front and rear)		
Double acting		
Axle, Front (rating)		
1,850 lb.		

Note: The Ford Courier Chassis-Cab model accommodates a second unit body of up to 700 lb. The completed vehicle may have a frontal area of up to 29 sq. ft. Requires std. 4-speed manual transmission, 4,100 lb. GVWR and optional 2.3L engine. Available in short or long wheelbase. Not available in California.

# Options

Factory options can multiply the usefulness and enjoyment of your Courier many times over. Ford-engineered, factory-installed and Ford-warranted, these options can also add to the trade-in value when it's time for a new Ford Truck.

**Appearance**  
 Exterior Decor Group. Includes bright drip rail and wheelip moldings; bright bodyside moldings with black vinyl inserts.  
 Tricolor accent tape stripe (B).

**Audio**  
 AM/FM monaural (E).  
**Comfort/Convenience**  
 Air conditioning. Includes three-speed fan and four air outlets for cool comfort. Designed to fit neatly up under the instrument panel.  
 Low-mount western swingaway mirrors (8 1/4" x 5 1/4").  
 Tinted glass — all around.  
 Soft Ride Package includes: 3,600 lb. GVWR and 5-leaf progressive-rate rear springs.  
 Argent rear step bumper (A).

**Free Wheeling Package**  
 Free Wheeling Package includes: Black-painted GT bar, push bar, tricolor accent tape stripe and deluxe wheel covers.

**Sport Group**  
 Gives you another kind of Courier. Includes temperature gauge and ammeter. Plus individually adjustable bucket seats trimmed in black vinyl with black and white plaid fabric inserts. A black, soft shift lever knob and bright argent instrument panel appliques. Black carpeting and interior trim (C).

**Performance**  
 2.3L engine.  
 5-spd. manual overdrive transmission (F).  
 Automatic transmission (D).

**Trailer Towing**  
 Courier is rated to haul Class I trailers (up to 21 sq. ft. frontal area) with standard GVWR and optional 2.3L engine (G).

**Tires and Wheels**  
 Radial tires — 195SR x 14B WSW.  
 Deluxe wheel covers.

**Options Availability**  
 1982 Ford Courier options are not confined to these pages but are shown throughout the catalog. Options, whether or not they are identified, are offered at extra cost. Some options are included, required, or are not available, in combination with other options. Availability of some models and features described here and elsewhere may be subject to delay. Consult your Ford Dealer for the latest information.

## Exterior Colors



\*Not available with XLT  
 \*\*Available at extra cost  
 Printed colors are at best only representative of the true paints. Your Ford Dealer can show you actual samples of paint colors and also interior trim materials.

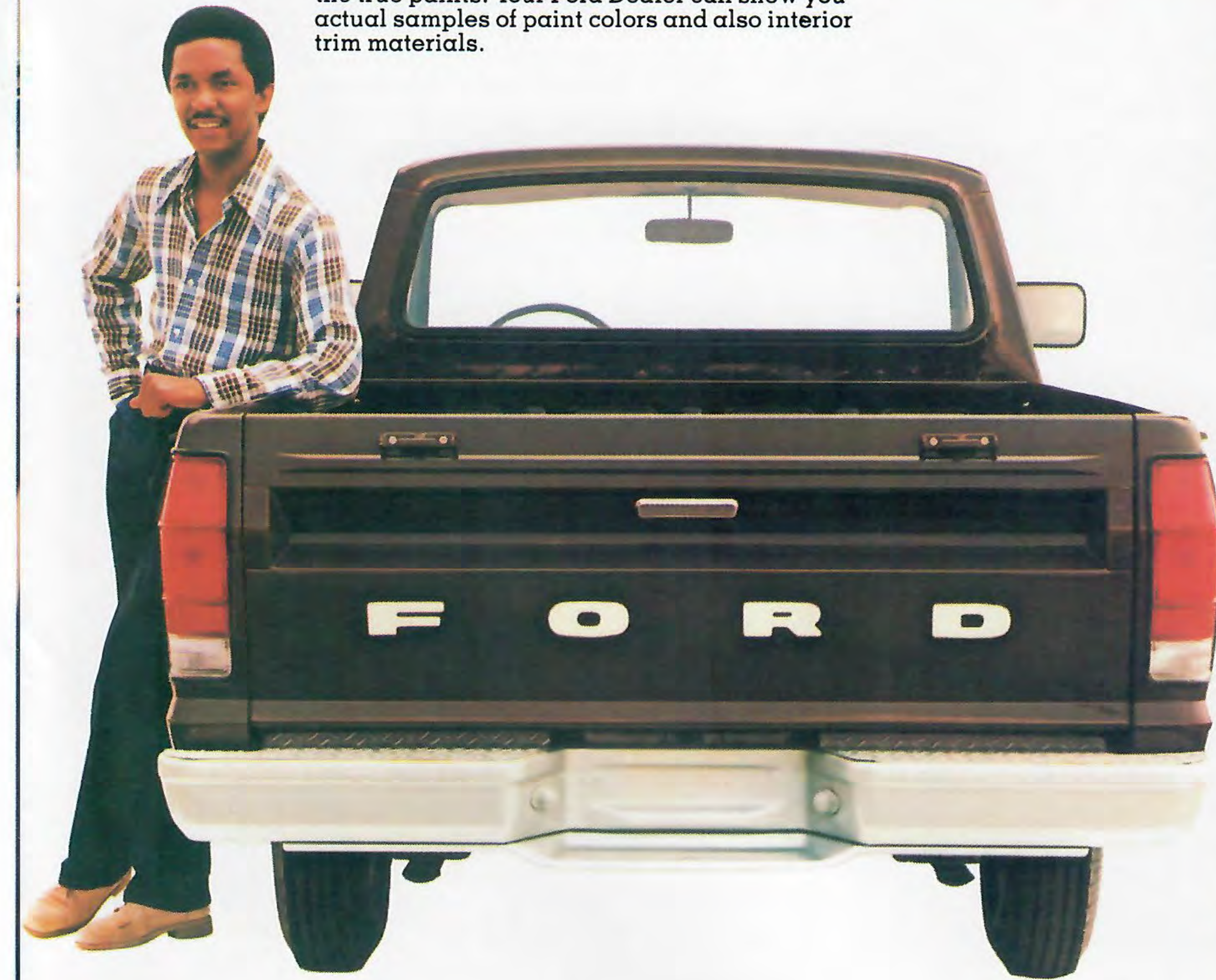

## DIMENSIONS

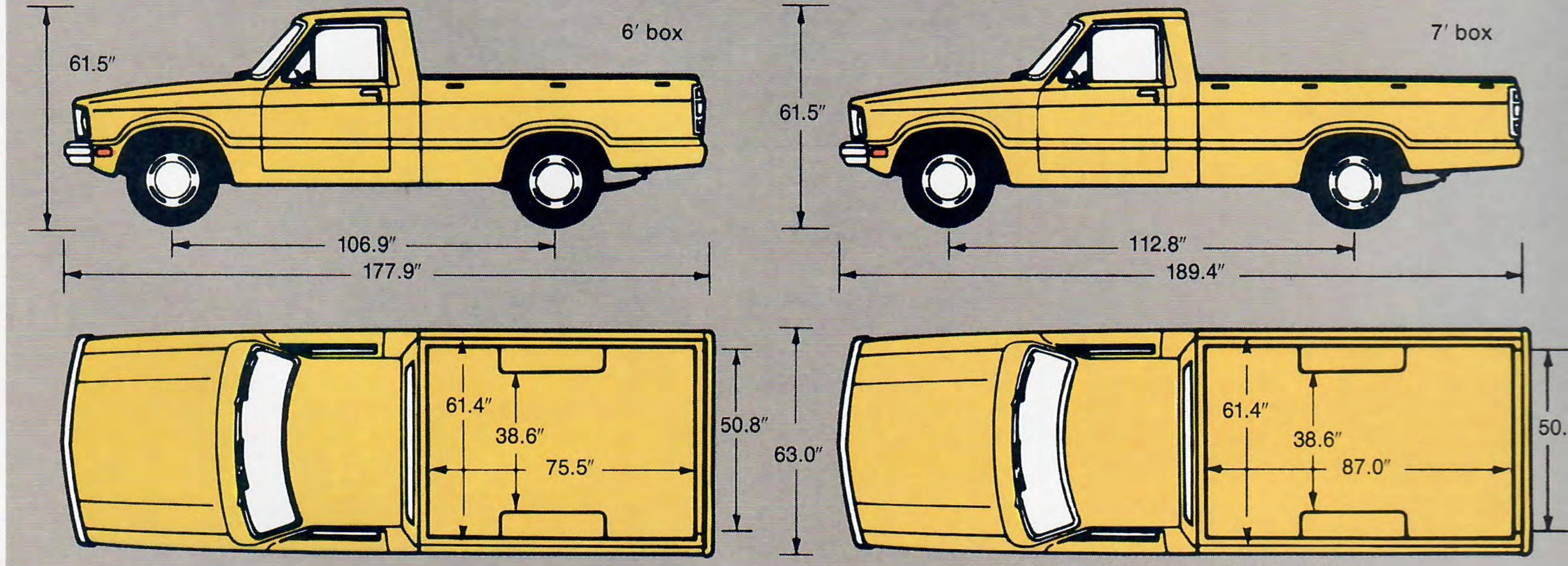

Pickup box dimensions shown at floor.



# '82 Ford Courier

## Ford-Paid Repair Programs after the Warranty Period

Sometimes Ford offers adjustment programs to pay all or part of the cost of certain repairs. These programs are intended to assist owners and are in addition to the warranty or to required recalls. Ask Ford or your dealer about such programs relating to your Ford or Lincoln-Mercury vehicle.

To get copies of any adjustment program for your vehicle or the vehicle of interest to you:

Call Ford toll-free at 1-800-241-3673. Alaska and Hawaii call 1-800-243-3711 and in Georgia call 1-800-282-0959.

Or write Ford at:

Ford Customer Information System  
Post Office Box 95427  
Atlanta, Georgia 30347.

We'll need your name and address; year, make, and model vehicle, as well as engine size; and whether you have a manual or automatic transmission.



## Replacement Parts

Be sure to specify genuine Ford-approved Motorcraft parts from your Ford Dealer.

...FOR SURE

Buy or lease a new Ford Courier  
from your Ford Dealer—  
a great choice either way!

## Technical Service Bulletins

All vehicles need repairs during their lifetime. Sometimes Ford issues Technical Service Bulletins (TSBs) and easy-to-read explanations describing unusual engine or transmission conditions which may lead to costly repairs, the recommended repairs, and new repair procedures. Often a repair now can prevent a more serious repair later. Ask Ford or your dealer for any such TSBs and explanations relating to your Ford or Lincoln-Mercury vehicle.

To get copies of these Technical Service Bulletins and explanations for your vehicle or the vehicle of interest to you:

Call Ford toll-free at 1-800-241-3673. Alaska and Hawaii call 1-800-243-3711 and in Georgia call 1-800-282-0959.

Or write Ford at:

Ford Customer Information System  
Post Office Box 95427  
Atlanta, Georgia 30347.

We'll need your name and address; year, make, and model vehicle, as well as engine size; and whether you have a manual or automatic transmission.

## Extended Service Plan

Ford Motor Company's optional Extended Service Plan covers major components on new Ford Couriers. The cost is so moderate for the protection you get that it could pay for itself the first time you need it. Your Ford Dealer will be happy to give you complete details of the Plan, which is available on cars and light trucks sold in all 50 United States and Canada.

## Ford Limited Corrosion Perforation Warranty

Ford Motor Company provides a limited 3-year, unlimited mileage corrosion perforation warranty on all trucks under 10,000 lb. GVWR sold in the 50 United States. The warranty states that any part which, in normal use, rusts through from corrosion within three years of retail delivery or first use will be repaired or replaced free of charge by the selling dealer after inspection by a Ford representative. Of course, exhaust system components or parts which develop corrosion perforation caused by accidents or other damage are not covered.

Specifications, descriptions and illustrative material contained herein were as accurate as known at the time this publication was approved for printing. Ford Division reserves the right to discontinue models or options at any time or change specifications and materials, equipment or design without notice and without incurring obligation. All options and accessories illustrated or referred to as optional or available in this publication are at extra cost. Some options are required in combination with other options. For the price of the model with the equipment you desire or verification of specifications contained herein, see your Ford Dealer.

# FORD COURIER

FORD DIVISION

