

# 1986 FORD MUSTANG





# FORD MUSTANG



**Mustang LX** spirits you away in 2-door sedan, 2-door hatchback and Convertible models. LX is a completely equipped car that's also very affordable.



**Mustang GT** is next with breathtaking performance in 2-door hatchback and Convertible models.



**Mustang SVO** features the sophisticated performance of a competition-bred machine.

If you've forgotten what it's like to experience driving for the pure joy of it, isn't it about time you jogged your memory a bit?

## **Ford Mustang for 1986...from the maker of the best built American cars.**

A 1985 survey of owners has established that Ford makes the best-built American cars. This is based on an average of problems reported by owners in the prior six months on 1981-84 models of all cars designed and built in the United States. Proof again that, at Ford... Quality is Job 1.

*At right: Mustang LX 2-Door Sedan in Dark Shadow Blue Metallic. Shown with one of Mustang's new Preferred Equipment Packages. For details, see pages 18-19.*

*Some equipment shown may be optional. See options list on page 21.*

## **Contents**

Ford Mustang Environment .....	8-9
Ford Mustang LX .....	10-11
Ford Mustang GT .....	12-13
Ford Mustang SVO .....	14-15
Ford Performance .....	16-17
Preferred Equipment Packages .....	18-19
Features, Options, Colors and Trims .....	20-21
Safety and Owner Information .....	22-23





SHOPPEKEEPERS II

OPEN





*Mustang GT 2-Door Hatchback  
in Dark Grey Metallic. Mustang  
GT Convertible in Bright Red.  
Some equipment shown may be  
optional. See options list on  
page 21.*

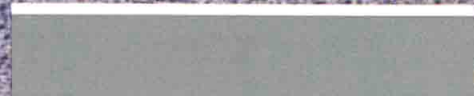





*Mustang GT interior in Canyon Red. Some equipment shown may be optional. See options list on page 21.*



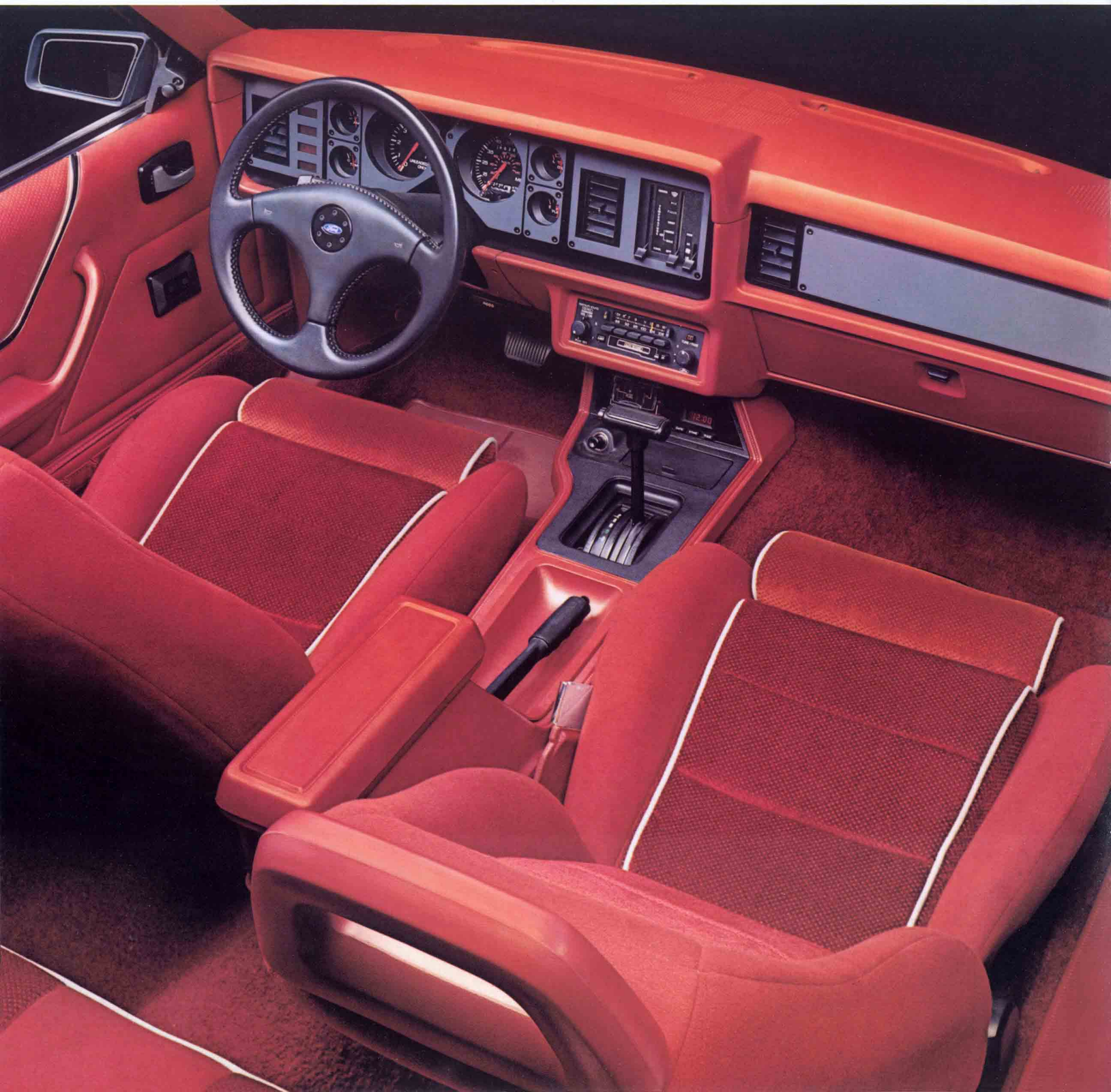



# ENVIRONMENT

## An interior designed for function, comfort and versatility



*Left: Mustang GT interior in Canyon Red.*

*Above top: The split fold-down rear seat in hatchback models offers extra flexibility for carrying passengers or cargo.*

*Above: Mustang GT instrumentation.*

*Some equipment shown may be optional. See options list on page 21.*

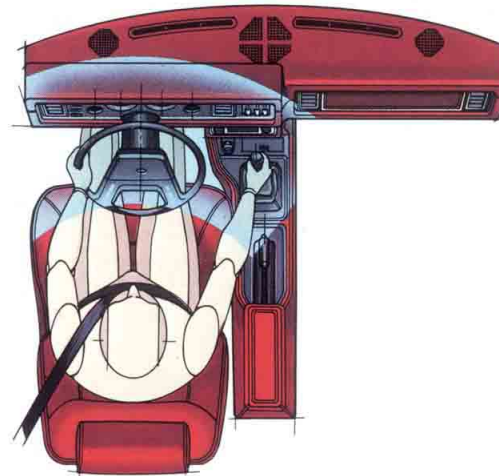

### Mustang's "command center"

In the Mustang driver's seat, you are placed in front of an array of controls and gauges designed to put you in complete command. The seating is firm and supportive to help eliminate fatigue during prolonged driving. The seat back angle is adjustable to suit the individual.

Instrumentation includes tachometer, speedometer, trip odometer, coolant temperature, ammeter, and oil pressure gauges. The climate controls and instruments are all lit with a red-orange glow for high visibility.

Multi-function controls for the interval windshield wipers/washer, turn signals, headlamp dimmer and flash-to-pass features are mounted at your fingertips on the steering column.

A console (standard on convertible and hatchback models) houses an electronic digital clock with elapsed time/day/date and stop watch functions as you select. Plus a graphic systems monitor (except SVO) that lets you know if fuel or windshield washer fluid is low and tells at a glance if headlamps, taillamps and parking lamps are functioning properly.

### Ford takes the science one step further

Passenger comfort is equally important in considering interior design. And Mustang's interior is just as inviting to them as it is to you.

All Mustangs are equipped with a Luxury Sound Insulation Package that helps keep outside noise outside. Deep cut-pile carpeting is standard in the passenger compartment. Mustang hatchback models have a completely carpeted cargo area including the rear fold down seat backs. In 2-door sedan models the trunk is also carpeted.

Other standard interior amenities that add to passenger and driver comfort are reclining front seat backs, AM/FM stereo radio with four speakers\* and dual covered visor mirrors. For a more complete listing, refer to the Features and Options list on page 21.

### Interior flexibility is another Mustang plus

Mustang hatchback models give the added convenience of a versatile rear passenger/cargo area. With both rear seat backs in the up position, there is 12.3-cubic feet of cargo carrying space. Fold both seat backs down and the capacity increases up to 30-cubic feet. Or, when conditions warrant, fold only one seat back down and still have room for one rear passenger. And all hatchbacks include a cargo area cover to keep valuables out of sight.

\*May be deleted for credit



# FORD MUSTANG LX

## The Mustang story begins with the well-appointed LX

Mustang LX's sporty appearance is tastefully trimmed with bright and charcoal accents. Full bodyside and decklid striping and dual remote-control charcoal mirrors are standard. All-season tread steel-belted radial tires and bright and black turbine wheel covers add to the sporty excitement.

The interior is completely trimmed with cut-pile carpeting, cloth headliner and cloth-covered sun visors. Visor mirrors with flip-up covers are also included. The full door trim panels are color keyed with a carpeted lower insert and bright and black moldings.

Other features that enhance Mustang LX's image are these desirable standards: AM/FM stereo

radio with four speakers;\* interval windshield wipers; Luxury Sound Package; power rack and pinion steering; power front disc/rear drum brakes and urethane lower bodyside protection.

To get you where you're going, Mustang LX is equipped with the 2.3 liter overhead cam 4-cylinder engine and 4-speed manual transmission. To keep it running at its best, the engine is monitored and controlled by Ford's EEC-IV computer control system. However, if your spirit clamors for a little more excitement in your day-to-day travels, you can always opt for the available 5.0 liter High Output EFI V-8 engine package.

\*May be deleted for credit



### Mustang LX Convertible. Open up your heart and let the sun shine in.

This Mustang model adds a whole new dimension to the world of driving enjoyment for you and up to three friends. Mustang Convertibles include a power retractable top, roll-down quarter windows, and a rear glass window that can be unzipped and folded down with the top up for added venti-

lation. Or, for convenience, the top can be lowered with the window in place. A rear luggage rack with integral high mount stop lamp is also standard.

LX Convertibles are powered by the 3.8 liter fuel injected V-6 engine and automatic transmission. Or, select the added performance of the optional 5.0L HO EFI V-8 with either the 5-speed manual or AOD transmissions.



### Mustang LX 2-Door Hatchback. All the LX attributes plus the advantages of a versatile interior.

The Mustang LX 2-Door Hatchback (not shown) is designed for the young and active. It's a car designed for those who need seating for four plus the versatility to carry a little extra cargo when required. Just fold down the rear seats, pack the gear in the back and you and your companion are ready for the great escape.

*Far left: Mustang LX front bucket seats in Canyon Red.*

*Above: Mustang LX Convertible in Oxford White.*

*Left: Mustang LX 5.0L 2-Door Sedan in Silver Metallic.*

*Some equipment shown may be optional. See options list on page 21.*



# FORD MUSTANG GT

## A rare blend of balance and power

For 1986, the Mustang GT 5.0 liter High Output V-8 power plant is virtually all-new featuring electronically controlled, sequential multiple-port fuel-injection, SAE rated at 200 horsepower.\* And it's available with the optional Automatic Overdrive transmission. Helping to keep all that power under control and efficiently transferring it to the road are a 5-speed manual overdrive transmission, Traction-Lok rear axle, special suspension components and 15-inch steel-belted radial ply Goodyear Eagle VR60 unidirectional performance tires.

### An interior that performs as well as the car

GT's articulated front sport seats are cloth and feature adjustable thigh and side cushion bolsters to help hold you snugly in place. In the rear of the hatchback model, a split fold-down seat provides a variable passenger/cargo area that's very accommodating. The standard console includes the

graphic systems monitor and digital clock.

Other performance features are quick ratio power steering (15:1) with increased effort for improved "road feel," tilting, soft-feel steering wheel, and a unique pedal package for "heel-and-toe" downshifting.

### What more could you ask for? How about a GT Convertible?

Imagine having all that performance and fun wrapped up in a convertible. Well, there's no need to imagine because Mustang GT performance comes in a convertible model as well. Complete with power retractable top, rear glass window and room for four. \*200 horsepower at 4,000 rpm. Based on SAE Standard J1349.



*Above: Mustang GT 2-Door Hatchback in Silver Metallic.*

*Right: Mustang GT instrument panel.*

*Far right: Mustang GT Convertible front bucket seats shown in Charcoal Grey with optional leather seating surfaces.*

*Some equipment shown may be optional. See options list on page 21.*





# FORD MUSTANG SVO

## Sophisticated performance for the knowledgeable driver.

SVO is built for those individuals who appreciate the performance and balance of a competition-bred machine. It is a limited production, high performance car with exceptional handling characteristics. A true enthusiast's car that begs to be driven.

SVO comes equipped with a 200 horsepower,\* 2.3 liter port fuel-injected, turbocharged, intercooled 4-cylinder engine. It's mated to a 5-speed manual overdrive transmission with special Hurst® shift linkage.

The suspension consists of gas-pressurized Koni® adjustable struts and shocks plus two additional horizontally mounted axle dampers in the rear.

To make sure the SVO is just as capable from 50-0 as it is from 0-50, it is also equipped with standard power-assisted, internally vented disc brakes at all four wheels.

SVO's performance stance is further accented by 16" cast aluminum wheels wrapped in performance "Gatorback" rubber. Aero-headlamps with their flush look, the functional hood scoop that feeds the intercooler and the rear dual wing spoiler tell you at a glance that this Mustang "tends to business" with the best.

### **SVO interior. Designed for the serious driver.**

Inside SVO's charcoal grey interior

are multi-adjustable, articulated sport performance seats. Adjustable features include: seat cushion side bolsters, under thigh support and inflatable lumbar support. The steering wheel, emergency brake handle and shift lever are leather wrapped. And there is a leather seating surface option.

Other features that enhance driver and passenger comfort are these impressive standards: Air conditioning. Power windows and door locks. Tilt steering wheel. Interval wipers. Rear window defroster. Electronic AM/FM stereo radio with cassette tape player and Premium Sound System. A console that incorporates an integral armrest/glove box, fog lamps switch, and fuel recalibration switch. The fuel recalibration switch optimizes engine performance regardless of the type of unleaded fuel you use, whether premium or regular.

Enough talk. You must drive an SVO to fully appreciate its capability.

\*At 5,000 rpm. Based on SAE Standard J1349.



*Above: Mustang SVO in Black.  
Far left: SVO interior.  
Center: SVO instrumentation.  
Left: Mustang SVO in White.*







## Ford performance over the road and under the hood

### A suspension system designed for smooth handling

One of the reasons for Mustang's excellent handling characteristics is the design of the front and rear suspension systems.

In front is a modified MacPherson strut setup. In this simple design, the strut replaces the upper control arm and joint of a conventional system resulting in fewer moving parts. A stabilizer bar connects the right and left lower suspension arms to promote flat, stable cornering.

The rear suspension is a 4-bar link design. It features four longitudinal arms that help control the position of the rear axle.

### Mustang GT

Mustang GT's suspension components are designed to match its higher performance capabilities. In front are gas-pressurized struts, variable rate springs and an upsized stabilizer bar. Variable rate springs and stabilizer bar are also used in the rear Quadra-shock suspension. In addition to the gas-pressurized rear shocks, there are two horizontally mounted axle dampers. These, along with the stabilizer bar, help to control the axle's fore and aft movement and resist torsional roll.

### Mustang SVO

SVO takes this excellent design one step further with the use of Koni® adjustable gas-pressurized shocks and struts.

### Power-assisted rack and pinion steering

Standard power-assisted rack and pinion steering adds to Mustang's fun-to-drive character. The feel of rack and pinion is firm and precise. GT and SVO feature high ratio 15:1 steering gears. And it contributes to Mustang's tight turning diameter of just over 39 feet, an important factor in overall maneuverability.

### Wheels and tires

The handling capabilities of GT and SVO are also greatly enhanced by VR speed-rated, steel-belted radial ply Goodyear Eagle performance tires. The tires, mounted on cast aluminum wheels (15-inch on GT and 16-inch on SVO), feature a unidirectional "Gatorback" tread design.

### Airflow as a stabilizing force

Mustang's dynamic design, in addition to contributing to fuel economy, also helps the steering and suspension systems. Through careful fine-tuning of selected design areas, air-flow is directed to reduce front and rear lift for directional stability and cornering agility.

### Efficient, responsive powerteams

The 2.3 liter overhead cam 4-cylinder engine and 4-speed manual transmission is the standard powerteam in Mustang LX 2-door and hatchback models. The overhead cam

design and single venturi carburetor along with EEC-IV computer control deliver excellent fuel economy.

### A powerteam with an accent on efficiency

The 3.8 liter V-6 engine (standard on LX Convertible) features central electronic fuel injection, advanced combustion chamber and intake valve design. It's teamed with an automatic transmission with a locking torque converter. The locking torque converter provides a near mechanical linkup between the engine and transmission in third gear, resulting in less torque converter slippage for more efficient use of power.

### The high performance 5.0 liter EFI High Output V-8

This High Output V-8, (rated at 200 horsepower at 4,000 rpm based on SAE standard J1349), is the standard engine in Mustang GT. And in 1986, it features sequential electronic multi-port fuel-injection to go along with a myriad of other performance components. Some of these include: high performance forged camshaft, low friction roller tappets, forged aluminum pistons, stainless steel tuned tubular exhaust headers, large diameter dual exhausts, and more. Harnessing all the power and transferring it to the road are standard Borg-Warner 5-speed manual overdrive transmission and Traction-Lok axle.

### Turbocharged, intercooled power: Mustang SVO

Mustang SVO's engine is an efficient, cross-flow head, overhead cam 4-cylinder. It displaces only 2.3 liters, yet through turbocharging and intercooling, it delivers horsepower and torque comparable to much larger V-8s. Other performance features are: five main bearings, forged aluminum pistons, high temperature alloy valves, auxiliary oil cooler, tuned intake manifold, automatic fuel shutoff, a refined knock sensor and more.

### Gas mileage

1986 EPA mileage estimates were not available at the time this catalog was approved for printing. As soon as EPA figures are released, your Ford Dealer will be among the first to receive this information and will be happy to pass it along to you.

### Mustang powerteams

Engine	Transmission	Axle Ratio		
		49-States	California	High Altitude
2.3L 1V OHC	Manual 4-speed*	Std 3.08:1	Std 3.08:1	Std 3.45:1
2.3L 1V OHC	Automatic	3.27:1	3.27:1	3.45:1
2.3L EFI Turbo with intercooler	Manual 5-speed	3.73:1	3.73:1	3.73:1
3.8L EFI	Automatic with locking torque converter	2.73:1	2.73:1	2.73:1
5.0L EFI HO	Manual 5-speed	Std. 2.73 Opt. 3.08	2.73 3.08	2.73 3.08
5.0L EFI HO	Automatic Overdrive	3.27:1	3.27:1	3.27:1

\*Includes upshift indicator light.



Left: Mustang LX 2-Door in Dark Shadow Blue Metallic; Mustang GT 2-Door Hatchback in Silver Metallic; Mustang SVO in Bright Red.

Some equipment shown may be optional. See options list on page 21.



# A WELL-EQUIPPED CAR

The Mustang LX 2-Door Sedan pictured below illustrates the high level of standard equipment included in this series. Included is Preferred Equipment Package 240A, with the kinds of features that have proved popular with many car buyers.



## Mustang 2-Door Sedan (with Preferred Equipment Package 240A):

- 2.3 liter OHC 4-cylinder engine, 4-speed manual transmission
- 3.08:1 rear axle
- P195/75R14 BSW steel-belted radial tires

- Dual remote-control outside mirrors
- Low-back reclining bucket seats
- Power rack and pinion steering
- Power front disc/rear drum brakes

- AM/FM stereo radio with four speakers
- Dual covered visor mirrors
- Interval wipers

- Dual covered visor mirrors
- Interval wipers
- Carpeted luggage compartment

- Rear stabilizer bar
- Full instrumentation
- Turbine wheel covers

# PREFERRED EQUIPMENT PACKAGES

Ordering your new Mustang is easy with Preferred Equipment Packages. Here's how it works: (1) Choose your body style (sedan, hatchback or convertible) and series (LX, GT or SVO). (2) Select the Preferred Equipment Package with the features you want from the charts below. Contents of Preferred Equipment Packages are subject to change. For the latest information, consult your Ford Dealer.

Mustang LX				
The following items of equipment are included on Mustang LX with Packages 240A, 242A, 243A and 244A.				
Equipment	Equip. Pkg. 240A	Equip. Pkg. 242A	Equip. Pkg. 243A	Equip. Pkg. 244A
4-speed manual transmission(1)	•	•	•	•
3.08:1 rear axle	•	•	•	•
P195/75R14 BSW steel-belted radial tires	•	•	•	•
Air conditioner		•	•	•
Rear window defroster(1)		•	•	•
Tinted glass, complete		•	•	•
Light Group(2)		•	•	•
AM/FM stereo radio with cassette player			•	•
Premium Sound System(2)			•	•
Speed control			•	•
Styled road wheels			•	•
Power Lock Group(2)			•	•
Tilt steering wheel				•
Power side windows				•

Mustang GT and SVO			
The following items are included on Mustang GT with Packages 250A and 251A and on SVO with Package 260A.			
Equipment	GT Equipment Package 250A	GT Equipment Package 251A	SVO Equipment Package 260A
Air conditioner	•	•	•
Rear window defroster(1)	•	•	•
Tinted glass, complete	•	•	•
Light Group(2)	•	•	•
AM/FM stereo radio with cassette player	•		
Premium Sound System(2)	•		
Power Lock Group(2)		•	•
Electronic AM/FM stereo radio with cassette player		•	•
Speed control		•	
Power side windows		•	•
5-speed manual overdrive transmission			•
Traction-Lok axle			•
P225/50VR 16 BSW unidirectional radial tires			•
• = Standard			

(1) NA on Convertible  
 (2) See "Footnotes for page 21," next page, for contents.

Mustang 2.3L Special Value	
When you purchase an LX Sedan or Hatchback with a 2.3 liter engine, the following will be included free.	
• Power Locks	• Speed Control
• Premium Sound System	• Styled Road Wheels



# FEATURES AND OPTIONS

Notable standard features and options for each Mustang series are listed on the facing page. In selecting the options you want, compare your choices with the Preferred Equipment Packages on page 19. You're likely to find that most of the equipment you want has already been conveniently included for you in a particular package. Options and their availability are subject to change during the year. Your Ford Dealer can advise you of current status.

## Electronic AM/FM stereo search radio

A few of the features of this state-of-the-art stereo sound system are: Dolby® noise reduction; seek tuning that selects the next listenable station either up or down the scale; scan tuning that auditions stations for eight seconds; and an "automatic music search" (AMS) for the cassette player that locates the beginning of the next or previous song on the tape.

## 5.0L V-8 engine with Electronic Fuel Injection.

Mustang LX can be equipped with the power of GT by ordering the 5.0L V-8 engine package. This year, the 5.0L includes electronic sequential multiple-port fuel injection and can be teamed with the Automatic Overdrive transmission as well as the 5-speed manual.

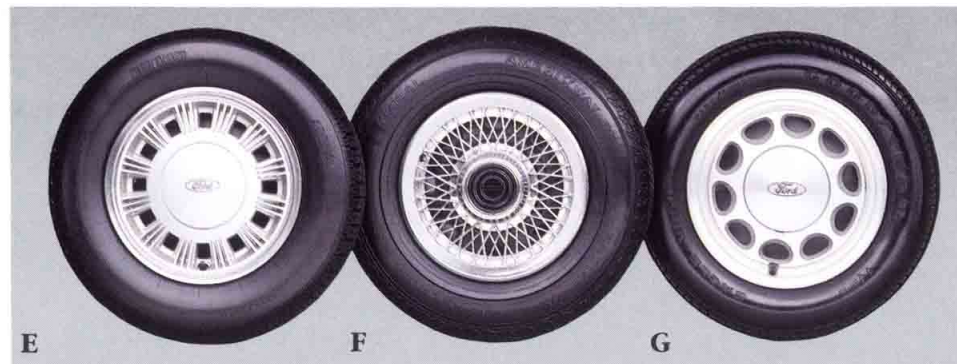

**Illustrated options (A)** Electronic AM/FM stereo search radio; **(B)** Air conditioner; **(C)** 5.0L EFI HO V-8 engine (some items shown have been chromed or painted for display purposes); **(D)** Tot-Guard for children 20-50 pounds (available at your Ford Dealer); **(E)** Styled road wheels; **(F)** Wire style wheel covers; **(G)** Cast aluminum wheels (standard on GT and required on LX with 5.0L V-8).



### Footnotes for page 21:

- (1) 36 amp-hour maintenance-free battery in LX 2- and 3-door, 45 amp-hour maintenance-free battery in LX Convertible; 54 amp-hour maintenance-free battery in GT and SVO.
- (2) Includes variable rate springs, gas-pressurized front struts, Quadra-shock rear suspension (gas-pressurized vertical shocks, hydraulic horizontal axle dampers), upsized front stabilizer bar, rear stabilizer bar, "quick-ratio" (15:1) steering gear, revised ball joints, front strut assembly and mount, lower spring insulator and front and rear spring dampers, adjusted spring and bushing rates.
- (3) Included with optional performance tires. Available only when 5.0L engine is ordered on LX.
- (4) SVO includes other unique components. See pages 14 and 15 for details.
- (5) See page 17.
- (6) Includes tachometer, trip odometer, oil pressure, temperature and ammeter gauges.
- (7) Includes adjustable head restraints, thigh and side bolsters. Available in Charcoal or White leather.
- (8) Includes electronic digital clock with day/date/elapsed time and stopwatch features, graphic display systems monitor. Rocker switches replace the systems monitor in SVO.
- (9) May be deleted for credit.
- (10) Includes upgraded speakers and 4-channel power amplifier. Required with electronic radio.
- (11) Includes power door locks, remote locking fuel door and trunk/liftgate release.
- (12) Includes lights for engine compartment, luggage compartment/cargo area, ashtray, glove box, dual beam dome/map light and headlamps on warning buzzer.
- (13) Available only with 5.0L powertrains.



## Ford Mustang Features and Options

FUNCTIONAL	LX			GT		SVO
	2-dr. Sedan	2-dr. Hbk.	Conv.	2-dr. Hbk.	Conv.	2-dr. Hbk.
2.3L OHC 1V 4-cylinder engine and 4-speed manual transmission	•	•				
2.3L OHC 1V 4-cylinder engine and automatic transmission	■	■				
2.3L EFI turbocharged, intercooled 4-cylinder engine with fuel octane selection capability and 5-speed manual overdrive transmission						•
3.8L EFI V-6 engine and automatic transmission	■	■	•			
5.0L EFI V-8 engine and 5-speed manual overdrive transmission	■	■	■	•	•	
Sport tuned dual exhaust system				•	•	•
5.0L EFI V-8 engine and automatic overdrive transmission	■	■	■	■	■	
Heavy-duty maintenance-free battery <sup>(1)</sup>	■	■	•	•	•	•
Power rack and pinion steering	•	•	•	•	•	•
Power front disc/rear drum brakes	•	•	•	•	•	•
Power four-wheel disc brakes						•
Handling suspension package <sup>(2)</sup>	■ <sup>(3)</sup>	■ <sup>(3)</sup>	■ <sup>(3)</sup>	•	•	• <sup>(4)</sup>
Standard and optional axle ratios <sup>(5)</sup>	■	■	■	■	■	•
Rear stabilizer bar	•	•	•	•	•	•
P195/75R14 BSW all-season tread tires	•	•	•			
P205/75R14 WSW all-season tread tires	■	■	■			
P225/60VR15 unidirectional Goodyear Eagle performance tires	■ <sup>(13)</sup>	■ <sup>(13)</sup>	■ <sup>(13)</sup>	•	•	
P225/50VR16 unidirectional Goodyear Eagle performance tires						•
<b>EXTERIOR</b>						
Halogen headlamps (aero-style on SVO)	•	•	•	•	•	•
Dual remote control mirrors	•	•	•	•	•	•
Marchal <sup>®</sup> fog lamps with covers				•	•	•
Dual wing rear spoiler with integrated high-mount stop lamp						•
Single wing rear spoiler with integrated high-mount stop lamp						■
Decklid luggage rack with integrated high-mount stop lamp	•		•			
Functional hood scoop						•
Flip-up open-air roof		■		■		■
Lower charcoal Two-Tone paint		■		■	■	
Turbine wheel covers	•	•	•			
Cast aluminum wheels	•	•	•	•	•	•
Wire style wheel covers	■	■	■			
Styled road wheels	■	■	■			

INTERIOR	LX			GT		SVO
	2-dr. Sedan	2-dr. Hbk.	Conv.	2-dr. Hbk.	Conv.	2-dr. Hbk.
Full instrumentation <sup>(6)</sup>	•	•	•	•	•	•
Reclining low back bucket seats	•	•	•			
Articulated sport seats in cloth trim with adjustable thigh and side bolsters and reclining seat backs (includes inflatable lumbar support in SVO)				•	•	•
Leather articulated sport seats <sup>(7)</sup>			■		■	■
Split fold-down rear seat		•				•
Console <sup>(8)</sup>	■	•	•	•	•	•
AM/FM stereo with 4 speakers <sup>(9)</sup>	•	•	•	•	•	•
AM/FM stereo with cassette	■	■	■	■	■	■
Electronic AM/FM stereo with cassette	■	■	■	■	■	•
Premium sound system <sup>(10)</sup>	■	■	■	■	■	•
Steering column mounted controls for turn signals, headlamp dimmer, flash-to-pass, interval wipers/washer system	•	•	•	•	•	•
Sport steering wheel, leather wrapped						•
Soft steering wheel				•	•	•
Tilt steering wheel	■	■	■	•	•	•
Leather wrapped gearshift handle and emergency brake handle						•
Rear window defroster	■	■		■		•
Air conditioner (tinted glass recommended)	■	■	■	■	■	•
Tinted glass, complete	■	■	•	•	•	•
Power windows	■	■	■	■	■	•
Power lock group <sup>(11)</sup>	■	■	■	■	■	•
Remote control fuel filler door release				•	•	•
Dual visor mirrors with covers (illuminated on SVO)	•	•	•	•	•	•
Light/Convenience group <sup>(12)</sup>	■	■	■	■	■	•
Carpeted luggage compartment/cargo area	•	•	•	•	•	•
Cargo area cover		•		•	•	•
• = Standard ■ = Optional						

## Colors & Trims

### Interior Trim Colors

Charcoal/Grey	Sand Beige/Buckskin	Canyon Red	Regatta Blue/Blue	Exterior Paint Colors
1, 2, 3	1, 2	1, 2	1	Black
1, 2, 3	1, 2	1, 2	1	Dark Grey Metallic
1, 2, 3	1	1, 2	1	Silver Metallic
1	1	1		Medium Canyon Red Metallic
1, 2, 3	1, 2	1, 2		Bright Red
1, 2, 3			1	Light Regatta Blue Metallic
3	1, 2			Dark Sage
	1			Dark Slate Metallic
1			1	Shadow Blue Metallic
1	1			Sand Beige
	1			Dark Clove Brown Metallic
1, 2, 3	1, 2	1, 2	1	Oxford White

1 = Mustang LX  
2 = Mustang GT  
3 = SVO

Some of these paint and trim colors are shown in this catalog. On the printed pages, of course, colors are at best only representative of the originals. Your Ford Dealer can show you actual samples of paint colors and trim materials, as well as Mustang color and trim availability.







Ford Motor Company strongly encourages all passengers to use their safety belts.

In all Ford cars, outboard front seat lap and shoulder belts have automatic retractors and comfort regulators. Outboard rear seat positions also have lap belts with retractors.

Ford urges the use of child and infant restraints, as required in all states. Ford's easy-to-install Tot-Guard (for children 20 to 50 pounds) and Infant Carrier (for children up to 20 pounds) are available at all Ford Dealers. If a child restraint requires a top-tether, Ford cars provide for attachment of an anchor at each rear outboard seating position (except Mustang Convertible).

## Ford Lifeguard Design Safety Features

### Vehicle operation

Safety rim wheels and load-rated tires  Split hydraulic brake system with warning light  Corrosion-resistant brake lines  Flash-to-pass headlamps  Turn indicator with lane-changing signal feature  Hazard warning flasher  Backup lights  Side marker lights  Parking lamps coupled with headlamps  Variable speed windshield wipers  Windshield washers  Dual outside rearview mirrors  Glare-reduced instrument panel, windshield wiper arms and windshield pillars  Uniform transmission shift quadrant (on all cars equipped with automatic transmission)  Continuously variable



control illumination intensity (instrument panel lighting)  Safety hood latch system  Function-rated windshield defroster system  High-mount brake lamp

### Occupant protection

Safety-designed front end structure  Safety-designed roof structure (except Convertibles)  Steel guard rails in side doors  Double yoke safety door latches and safety hinges  Integral lap and shoulder belts with automatic retractors for occupants of front seats  Positive seat belt fastening reminder warning light and buzzer for the driver's seat  Lap belts for rear seat occupants  Energy-absorbing steering column and steering wheel

system  Energy-absorbing armrests and safety-designed door handles  Energy-absorbing instrument panel with padding for right front passenger  Energy-absorbing sun visors  Energy-absorbing front seat back tops with padding  Self-locking front seat backs  Head restraints for front outboard occupants  Safety glove box latch  Inside yieldaway rearview mirror  Impact-absorbing laminated safety glass windshield  Flame resistant interior materials  Safety-designed coat hooks  Safety-designed radio control knobs and push buttons

### Special quality steps: Corrosion protection

Ford takes tough measures to protect its cars against the damaging effects of corrosion. Galvanized steel is used for important underbody and structural parts. Pre-coated steel, featuring corrosion inhibitors, is also used in major body panels. Special treatments are applied to selected areas of the body structure.

### Scheduled maintenance

Here are some examples of scheduled maintenance intervals for the 1986 Mustang. For complete maintenance recommendations, refer to the Mustang Owner Guide.

Engine oil change (2.3L, 3.8L, 5.0L)	each 7,500 miles
Turbo	each 5,000 miles
Spark plug change	each 30,000 miles
Turbo	each 15,000 miles
Air filter replacement	each 30,000 miles
Engine coolant replacement	each 30,000 miles or 3 years

### "Ask your Ford Dealer"

*Following publication of this catalog, certain changes in standard equipment, options, prices and the like, or product delays, may have occurred which would not be included in these pages. Your Ford Dealer is your best source for up-to-date information.*



# SAFETY AND OWNER INFORMATION

## Measurements

	Sed/Hbk	SVO
Wheelbase	100.1"	100.5"
Length	179.1"	180.8"
Height	52.1"	52.1"
Width	69.1"	69.1"
Tread: front	56.6"	57.8"
Tread: rear	57.0"	58.3"
Trunk or cargo volume (cu. ft.)	10/30 *	30 *
Fuel capacity (gal.)	15.4	15.4
Curb weight (lb.) **	2733/2791	3,140
Passenger capacity	4	

\* With rear seats down.

\*\* Convertible weight 3,044 lbs.

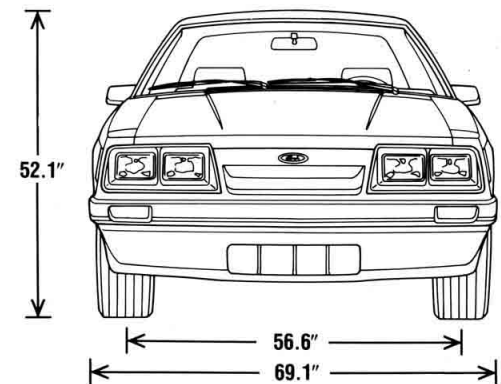
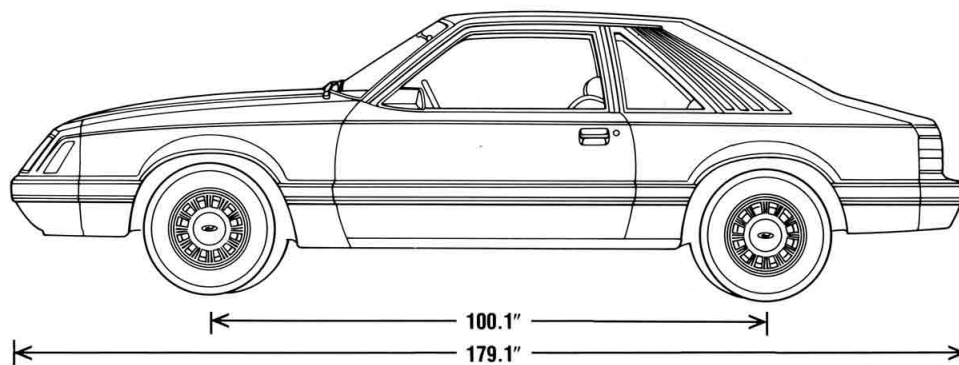

## 5-mile-an-hour bumpers

Bumpers on Mustang are designed to protect lamps, cooling system, exhaust and other body components in the event of a minor impact. While some manufacturers equip their cars with bumpers that just meet the 2½-mph federal standards, Ford equips the new Mustang and every other car it makes with bumpers designed to absorb impacts of 5-mph.



Participating Ford Dealers are now offering the Lifetime Service Guarantee which guarantees their work on your Ford vehicle for as long as you own it. This means that the covered repair is paid for once — and never again. If it ever has to be fixed again, the repairing dealer will fix it free. Free parts. Free labor even if the car is kept a lifetime. It doesn't matter where it was purchased, or whether it was new or used; the work is still covered by the repairing dealer.

This limited warranty covers vehicles in normal use. Items not covered are routine maintenance parts, belts, hoses, sheet metal and upholstery.

Ask to see this guarantee when you visit your participating Ford Dealer.



The optional Extended Service Plan covers major components on new Ford cars and light trucks for longer than the vehicle's basic warranty. The cost of this added protection is so moderate that it could pay for itself the first time you need it. Your Ford Dealer has full details.



Genuine Ford and Motorcraft original equipment replacement parts meet the same high standards as those installed in production. They are your best assurance of quality and long term satisfaction.

## Ford-paid repair programs after the warranty period

Sometimes Ford offers adjustment programs to pay all or part of the cost of certain repairs. These programs are intended to assist owners and are in addition to the warranty or to required recalls. Ask Ford or your dealer about such programs relating to your Ford or Lincoln-Mercury vehicle.

To get copies of any adjustment program for your vehicle or the vehicle of interest to you: Call Ford toll-free at 1-800-241-3673. Alaska/Hawaii call 1-800-241-3711 and in Georgia call 1-800-282-0959.

Or write Ford at:  
Ford Customer Information System  
Post Office Box 95427  
Atlanta, Georgia 30347

We'll need your name and address; year, make and model vehicle, as well as engine size; and whether you have a manual or automatic transmission.

## Technical service bulletins

All vehicles need repairs during their lifetime. Sometimes Ford issues technical service bulletins (TSBs) and easy-to-read explanations describing unusual engine or transmission conditions which may lead to costly repairs, the recommended repairs, and new repair procedures. Often a repair now can prevent a more serious repair later. Ask Ford or your dealer for any such TSBs and

explanations relating to your Ford or Lincoln-Mercury vehicle.

To get copies of these technical service bulletins and explanations for your vehicle or the vehicle of interest to you: Call Ford toll-free at 1-800-241-3673. Alaska/Hawaii call 1-800-241-3711 and in Georgia call 1-800-282-0959.

Or write Ford at:  
Ford Customer Information System  
Post Office Box 95427  
Atlanta, Georgia 30347

We'll need your name and address; year, make and model vehicle, as well as engine size; and whether you have a manual or automatic transmission.

## Options availability

Options shown or described in this catalog are available at extra cost and may be offered only in combination with other options or subject to additional ordering requirements or limitations.

## Product changes

Ford Division reserves the right to change product specifications at any time without incurring obligations.

## Buy or lease a new Ford Mustang



Have you driven a Ford...lately?



FORD MUSTANG

