

1990 FORD MUSTANG





MUSTANG GT

To survive in the world of automobiles, you need to be strong. You need to provide what the driving public demands or you won't last very long. After 25 years, Mustang is not only still around, but is as strong and as popular as ever.

Mustang GT is one of the reasons. Bold, aggressive styling. The powerful 5.0L V-8 under the hood. Firm handling suspension. Fat, performance radials. It's a combination that begs to be driven.

The 5.0 liter V-8 puts out 225 horsepower at 4,200 rpm and 300 lb. ft. of torque at only 3,200 rpm.

Putting all that torque to good use is a Borg-Warner 5-speed with fifth gear overdrive and standard rear Traction-Lok axle. If you prefer, order the convenience of the optional 4-speed Automatic Overdrive transmission.

The handling suspension system uses nitrogen gas-pressurized hydraulic struts in front with Ford's Quadra-Shock system in the rear and progressive rate coil springs at all corners.

GT's long list of standard performance features is quite impressive. You can find out more about them on pages 10-11.

After 25 years, Mustang is not only still around, but is as strong and popular as ever.

GT's aggressive stance is due in part to its "ground effects" styling. The low-profile hood, front and rear fascias, front air dam, integrated fender extensions with scoops, and rear decklid spoiler all contribute to GT's bold look.

This year, you can select the option of rich leather seating surfaces for the GT interior. The front articulated bucket seats offer power adjustable lumbar supports, manually adjustable side bolsters and under-thigh supports, plus reclining seat backs.

Easily seen through the leather-wrapped steering wheel, are a full complement of analog gauges including a 7,000 rpm tach, voltmeter, temperature and oil pressure gauges. The brake and accelerator pedals are positioned to allow heel-and-toe downshifting and there is a left side foot rest/support for the driver.



▲ Mustang GT hatchback in Bright Red.

◀ Mustang GT convertible in Cabernet Red. Some equipment shown is optional.

MUSTANG LX 5.0L

Restrained excitement. That would be one way to describe the Mustang LX 5.0L. Introduced in 1989, the LX 5.0L was an immediate success. And with good reason. With the LX 5.0L you get the smooth, clean styling of the Mustang LX model, plus all of the performance attributes of the GT. And it's available in 2-door hatchback, 2-door sedan and convertible models.

Under the hood is the powerful 5.0L V-8 putting out 225 horsepower and 300 lb. ft. of torque.

The handling suspension system is the same as that used for the GT. Nitrogen gas-pressurized hydrau-



Introduced in 1989, the LX 5.0L was an immediate success.

lic front struts and rear Quadra-Shock set-up for that performance ride. Progressive-rate coil springs at the corners.

Quick 14.7:1 constant ratio steering, Traction-Lok axle, P225/60VRx15 performance tires and 10-hole cast aluminum wheels.

Inside the hatchback and convertible models are the articulated, multi-adjustable front bucket seats (available this year with optional Titanium leather seating surfaces), brake and accelerator pedals that are positioned to allow heel-and-toe downshifting, soft-feel steering wheel and electronic AM/FM stereo.

Convertible models are a big part of Mustang fun. Just lower the power retractable top and experience the driving freedom that only a convertible can give.



◀ Mustang LX 5.0L 2-door sedan in Bright Red.



◀ Mustang LX 5.0L 2-door hatchback in Bright Yellow Clearcoat.

▶ Mustang LX 5.0L convertible in Oxford White. Some equipment shown is optional.



FORD MUSTANG LX

After 25 years, Mustang's personality remains unchanged. Simply put, Mustang in its purest form is just plain fun to drive.

The standard LX, featured on these two pages, is a perfect example of that personality. It's powered by a responsive 2.3 liter overhead cam 4-cylinder engine with electronically controlled multiple-port fuel injection. The manual transmission adds to the fun with five forward speeds (fifth gear overdrive).

And LX is well equipped, too. Power rack-and-pinion steering and power front disc/rear drum brakes are standard.

Inside are reclining low back bucket seats and center console. Full analog instrumentation is also

Mustang in its purest form is just plain fun to drive.

standard along with an electronic AM/FM stereo search radio with four speakers. For a more complete look at Mustang LX major standard features, see the chart on page 13.

New for 1990 in all Mustang models is the standard Driver's Side

Air Bag Supplemental Restraint System, or SRS. When used in conjunction with the 3-point safety belts, it provides an extra measure of protection for the driver.

Hatchback models feature a split/fold rear seat and fully carpeted cargo area with a window shade-type cover. The split/fold design rear seat gives versatility in the cargo area as well as access to 30 cubic feet of space (both seat backs down).

Mustang LX is also available in

a convertible model. It comes complete with a power retractable top and rear glass fold down window. Convertibles also have a few other standard features over the other bodystyles. Such as power side windows (including the rear quarter windows), dual electric remote-control mirrors, power lock group, and more.

MUSTANG SPECIAL VALUE PROGRAM

The Mustang Special Value option is what some might call, "...an offer you can't refuse."

With it you can get the power lock group, dual electric remote control mirrors, electronic AM/FM stereo with cassette player, speed control and power side windows—all at no additional charge.



◀ Mustang LX 2-door hatchback in Oxford White.



◀ Mustang LX convertible in Black. Some equipment shown is optional.

▶ Mustang LX 2-door sedan in Twilight Blue Clearcoat Metallic.



MUSTANG INTERIOR

Nothing contributes more to the enjoyment of driving a Mustang than the sporty interior.

Mustang's front bucket seats are designed to be firm and supportive to help reduce fatigue. High density foam pads in the seat cushion and seat back side bolsters give a wraparound effect to help hold you in place. The front seat backs recline and the headrests are adjustable two-ways.

The rear bench seat provides room for two and in hatchback models it has a split-fold design.

In the performance-minded LX 5.0L (hatchback and convertible) and GT models, the articulated front bucket seats feature adjustable seat cushion side bolsters and a power adjustable lumbar support. There's also an adjustable under-thigh support.

The standard AM/FM stereo radio is electronically tuned and features four-speaker sound. Or, order the optional electronic AM/FM stereo with cassette tape player. Round that out with Premium Sound that adds an 80-watt power amplifier.

The analog gauges are large and easy to read. And there is a full complement: fuel, engine coolant temperature, voltmeter, oil pressure and tachometer.

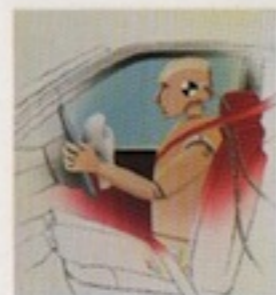

▲ Mustang's standard Driver Air Bag Supplemental Restraint System.



▲ Mustang LX interior in Scarlet Red.



▲ Mustang LX instrument panel in Bright Red.



DRIVER AIR BAG SUPPLEMENTAL RESTRAINT SYSTEM (SRS)

New for 1990 is a driver air bag supplemental restraint system as standard equipment.

The supplemental air bag, located in a module in the center of the steering wheel, is designed to activate in the event of a moderate to severe frontal impact roughly equivalent to striking a parked car of similar size at 28 miles per hour.

From initial impact to full deployment, the air bag inflates in less than 1/10 of a second. It also begins to deflate within a fraction of a second.

The supplemental air bag is designed for one use. Once used, the module must be removed and replaced by a qualified service technician. Replacement is normally covered by the insurance company as part of the collision repair. In addition, many insurance companies are offering discounts on the medical premiums for cars equipped with air bags.

It is very important to remember that the air bag is intended to supplement, not replace, the driver's conventional lap and shoulder belt. The safety belt system helps provide protection in all types of impacts. When used together, air bags and safety belts comprise one of the best occupant restraint systems available today.

► Mustang GT interior shown in Titanium. Some equipment shown is optional.



FORD MUSTANG ENGINEERING

Driving. That's what Ford Mustang is all about. City streets or open road, Mustang responds to you. And each Mustang model is designed to respond in a slightly different manner.

The LX achieves its ride characteristics with nitrogen gas-pressurized hydraulic struts and stabilizer bar in front along with nitrogen gas-pressurized hydraulic shocks in the rear.

In the LX 5.0L and GT models, the suspensions are designed to match their higher performance capabilities. Some of those components are progressive rate springs and a larger stabilizer bar in front. In the rear is the Quadra-Shock system, incorporating two vertically-mounted nitrogen gas-pressurized hydraulic shocks, two horizontally-mounted hydraulic axle dampers and a stabilizer bar.

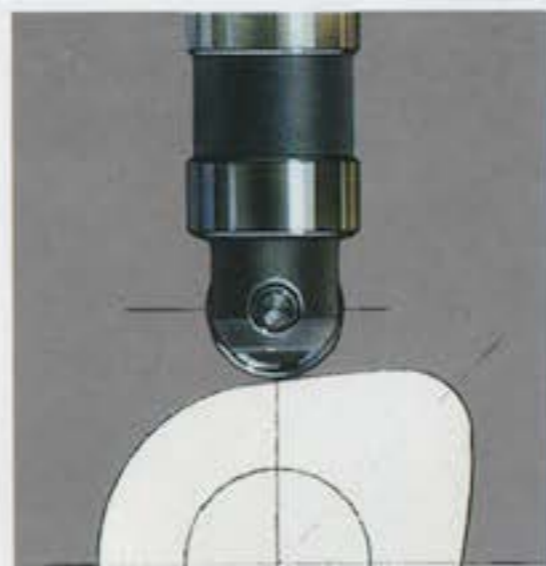

▲ Roller tappets in the 5.0L help reduce friction and heat.

MUSTANG POWER

The 2.3L engine that powers Mustang LX models is a 4-cylinder in-line type with a single overhead cam and modified wedge combustion chambers. It features electronic multiple-port fuel injection and electronic engine control through the EEC-IV computer.

In GT and the LX 5.0L, the high-output V-8 is rated at 225 horsepower at 4,200 rpm. It also delivers 300 lb. ft. of torque at 3,200 rpm.

Some of the components used to reach those impressive figures are: SEFI; high performance induction-hardened camshaft; low friction roller tappets; double-roller timing chain; forged aluminum alloy pistons; tuned stainless steel tubular headers; large diameter dual exhausts and much more.

A standard 5-speed manual transmission with overdrive fifth gear lets you utilize all that power with the precision of direct linkage shifting.

Gear ratios for the 5-speed are: 1st gear-3.35; 2nd gear-1.93; 3rd gear-1.29; 4th gear-1.00; 5th gear-0.68.

► The 5.0L engine has a proven overhead valve design with modified combustion chambers. The block and heads are cast iron and the intake manifold is aluminum. It uses forged aluminum alloy pistons for light weight and good heat dissipation. The connecting rods are forged steel for strength.

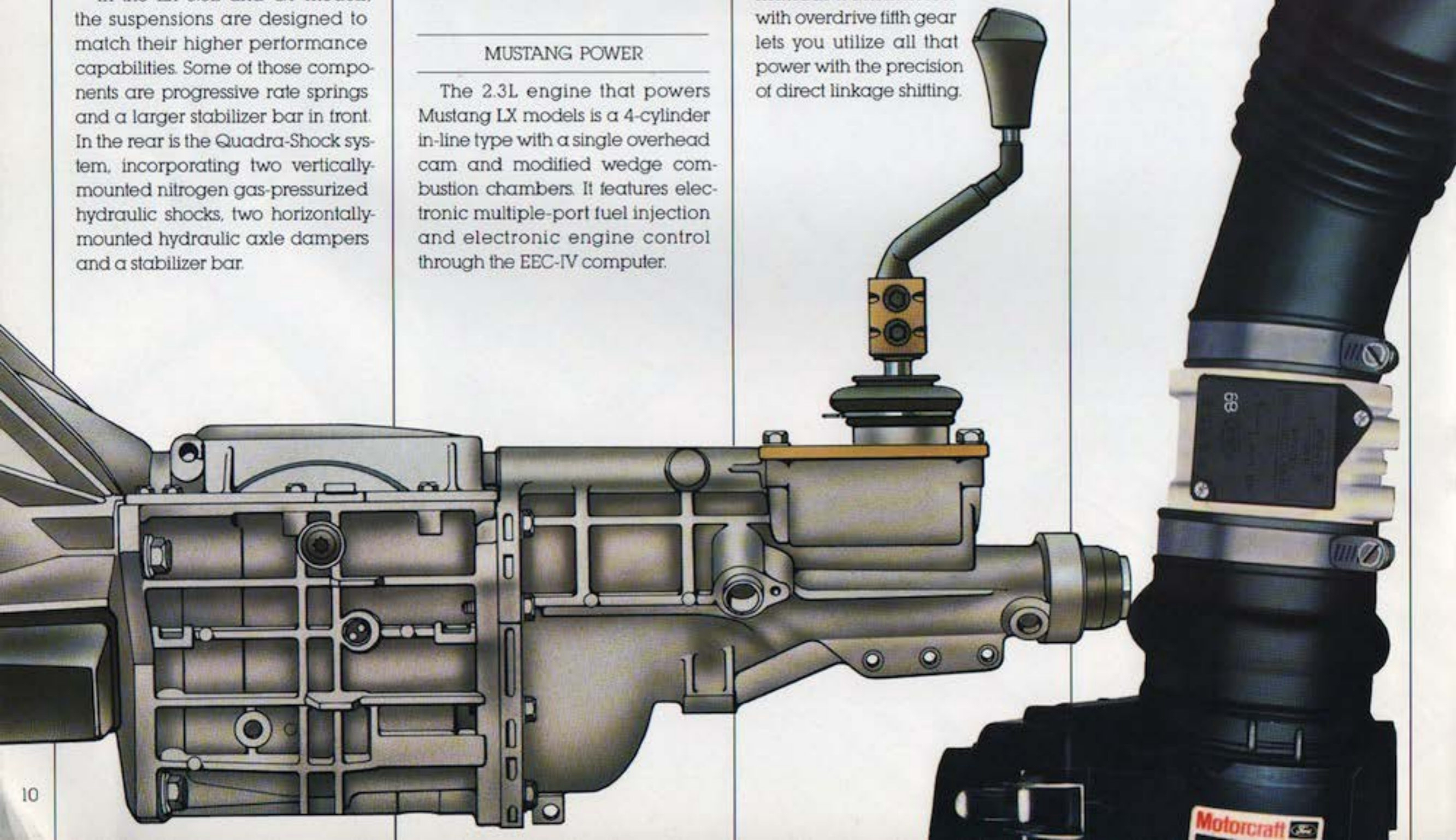

5.0 *Ford* **HO**



OPTIONS AND SPECIAL VALUE GROUPS

Your 1990 Mustang, whether the LX, LX 5.0L or GT model, comes equipped with a high level of standard equipment. Many of those features are noted in the Major Standard Features list on the next page.

Of course, if you would like to personalize your Mustang even more, you may do so in a number of ways.

First, consider a Preferred Equipment Package. These Packages combine popular options at significant savings when compared to the cost of the same options ordered separately. These packages are detailed in the Preferred Equipment Package portion of the chart on the next page.

Package content is subject to change. See your Ford Dealer for details.

Next, take a look at the list of individual options included in the bottom of the chart. Individual options allow you to add a little or a lot depending on your needs.

Automatic Overdrive Transmission—manual transmissions are great—for some people—but if they're not for you, this option is a must. The Automatic Overdrive transmission is available on all Mustang models, even GT.

Flip-up Open-air Roof—if you like the feeling of the open air but are sold on the versatility of the hatchback model, you should consider this attractive alternative. Available on hatchbacks only, the flip-up glass panel is convenient and easy to use. It can be flipped up partially or removed completely.

MUSTANG LX SPECIAL VALUE PROGRAM

When you purchase your Mustang LX with Preferred Equipment Package 240A you will receive the following package of equipment at no extra charge:

Electronic AM/FM stereo radio with cassette tape player and integral digital clock (in place of the standard electronic AM/FM stereo), speed control, dual electric remote-control mirrors, power side windows and the Power Lock Group which includes door locks and remote trunk/hatch release.

LX 5.0L AND GT SPECIAL VALUE PROGRAM

If you purchase either of these models, the LX 5.0L or the GT, with their respective Preferred Equipment Packages 245A and 249A, you will receive air conditioning at no extra charge.



A. Electronic AM/FM stereo with cassette tape player

B. Air conditioning with rotary controls

C. Flip-up open-air roof for hatchbacks

D. Rear window defroster

SAFETY AND OWNER BENEFITS

SMART & SAVVY CHOICES

PREFERRED EQUIPMENT PACKAGES (Note: Package content subject to change) ■ = Included in package S = Standard 0 = Optional	LX 240A	LX 5.0L 245A	GT 249A
2.3L EFI engine	S		
5.0L EFI engine		S	S
Power Equipment Group (1) Includes: Power Lock Group with door locks and remote trunk/hatch release, dual electric remote control mirrors, power side windows	■	■	■
Speed control	■	■	■
Electronic AM/FM stereo radio with cassette player and integral digital clock	■	■	■
Premium Sound System	0	■	■
Radio credit option (2)	0	0	0
Custom Equipment Group Includes: air conditioning, dual illuminated visor mirrors (3)	0	■	■
Other options			
Automatic transmission	0	0	0
Rear window defroster (4)	0	0	0
Clearcoat paint	0	0	0
Flip-up open-air roof (5)	0	0	0
Vinyl seat trim	0		
Leather seat trim (6)		0	0
Titanium lower accent bodyside treatment (7)			0
Performance tires P225/60VRx15		S	S
WSW tires	0		
Wire style wheel covers	0		

MAJOR
STANDARD
FEATURES

EXTERIOR

- Flush, aerodynamic halogen headlamps
- Urethane lower bodyside protection
- Bodyside protection moldings
- Flush quarter window glass (sedans and hatchbacks)
- Wraparound taillamps
- Dual remote-control mirrors, RH convex (sedans and hatchbacks)
- Color coordinated bodyside paint stripe
- Single wing rear spoiler with integrated stop lamp (hatchbacks)
- Finned wheel covers
- 10-hole cast aluminum wheels (LX 5.0L)
- 16-spoke cast aluminum wheels (GT)
- Ground effects styling (GT)
- Fog lamps (GT)

INTERIOR

- Driver air bag Supplemental Restraint System (SRS)
- Rear passenger 3-point active lap/shoulder belt restraint system
- Front and rear ashtrays
- 16-oz. carpeting
- Cargo area cover (hatchbacks)
- Center console
- Cigarette lighter, front
- Clock, electronic (integral with radio)
- Driver's side footrest/support
- Full instrumentation—tachometer, trip odometer, voltmeter, temperature, fuel and oil pressure gauges
- Alert lights for low oil check, low coolant, low fuel and low washer fluid (GT)
- Glove box, locking
- Light Group—lamps in dome (integrated in mirror on convertibles) with door courtesy switches, lights in engine compartment, luggage or cargo compartment, glove box, front ashtray and "headlamps on" alert chime
- Pivoting header-mounted map light (hatchbacks)
- Dual visor mirrors with covers
- Split/fold-down rear seatbacks (hatchbacks)
- Stalk-mounted controls
- Low back reclining cloth front bucket seats with cloth headrests (2-door)
- Articulated front sport seats, cloth trim, two-way headrests and power lumbar supports (hatchbacks and convertibles)
- Full wrapover door trim panels with full length armrests and map pockets
- Power Lock Group—power door locks, power decklid/hatch release
- Side window demisters
- Tinted glass
- Electronic AM/FM stereo seek radio with integral digital clock and four speakers
- Interval wipers
- Luxury Sound Insulation Package

Convertibles

- Power retractable top with glass rear window
- Luggage rack with integrated stop lamp
- Dual electric remote control mirrors, RH convex
- Power side and quarter windows
- Footwell courtesy lights

(1) Standard on convertible. (2) No radio installed. (3) Dual illuminated visor mirrors not available on convertible. (4) Not available on convertibles. (5) Hatchbacks only. (6) Not available on LX 5.0L sedan. (7) Available with selected GT colors.

SPECIFICATIONS, COLORS & TRIMS

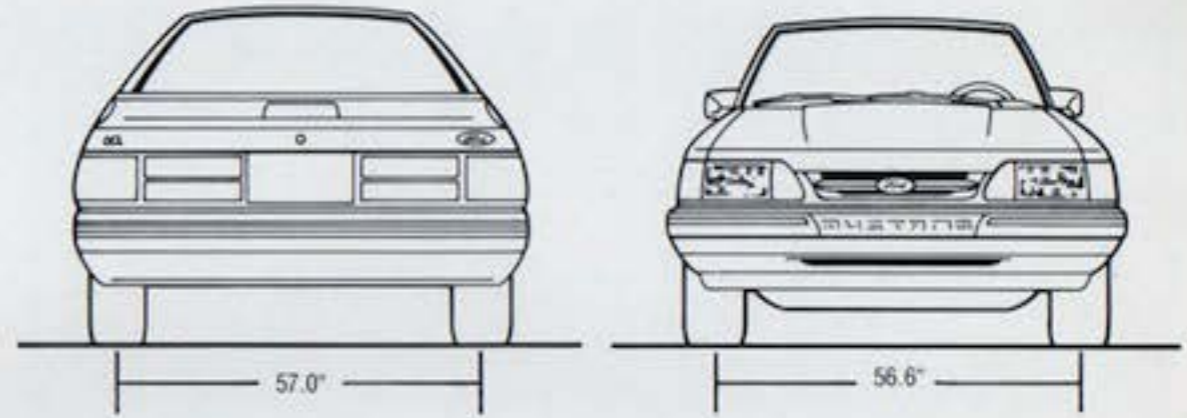
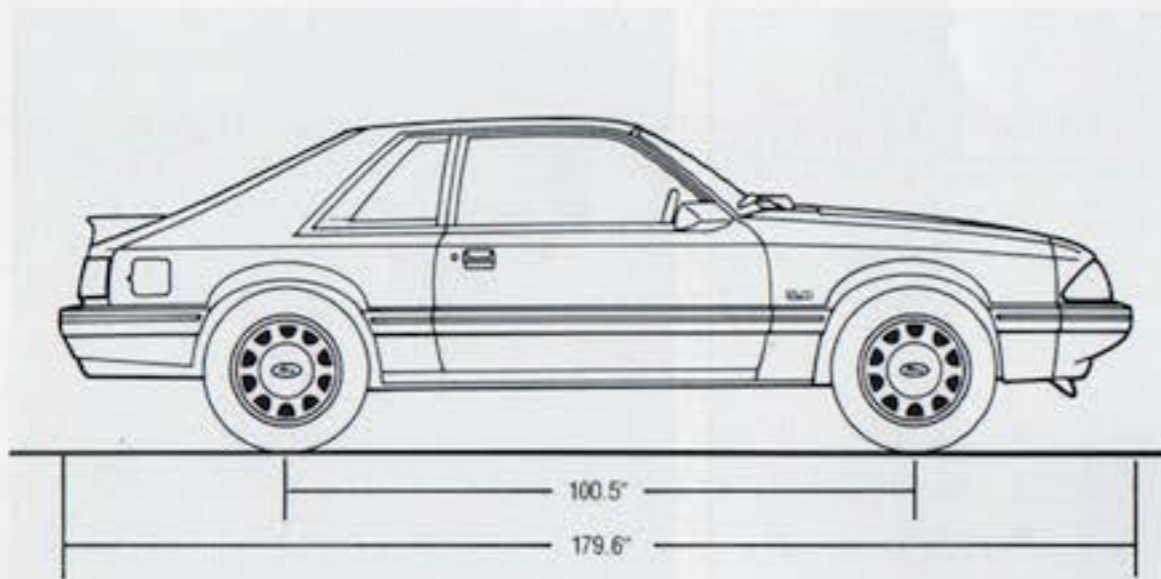

DIMENSIONS

	2-Door Sedan	2-Door Hatchback	Convertible
Wheelbase	100.5"	100.5"	100.5"
Length	179.6"	179.6"	179.6"
Height	52.1"	52.1"	52.1"
Width	68.3"	68.3"	68.3"
Front tread	56.6"(1)	56.6"(1)	56.6"
Rear tread	57.0"	57.0"	57.0"
Trunk or cargo volume (cu. ft.)	10.0	30.0(2)	6.4
Passenger capacity	4	4	4

(1) 57.9 on GT
(2) 12.2 cu. ft. with rear seat backs up.

COLORS AND TRIMS—MUSTANG LX, LX 5.0L, GT

Interior Colors					Exterior Colors
Crystal Blue	Scarlet Red(1)	Titanium(1)	Black(1)	White(4)	
	X	X	X	X	Black(1)
X	X	X	X	X	Oxford White(1)
	X	X	X	X	Bright Red(1)
	X	X	X	X	Cabernet Red(2)
			X	X	Extra cost Clearcoat paint
					Bright Yellow(1)
	X	X	X	X	Deep Titanium Metallic(2)
X	X	X	X	X	Light Titanium Metallic(2)
	X	X	X	X	Wild Strawberry Metallic(2)
X			X	X	Crystal Blue Metallic
X		X		X	Twilight Blue Metallic(2)
X		X		X	Ultra Blue Metallic(2)
				X	Deep Emerald Green Metallic(3)

(1) Available on GT; (2) Available on GT with optional Titanium Lower Accent Treatment; (3) Limited model and late availability. See your dealer for details.
(4) Available in convertible with White/Red, White/Blue, White/Titanium door trim panel and carpet color combinations. See your dealer for details.
Some of these paint and trim colors are shown in this catalog. On the printed page, of course, colors are at best only representative of the originals. Your Ford Dealer can show you actual samples of paint colors and trim materials.

MUSTANG GT AND LX 5.0L

Engine type	5.0L overhead valve V-8
Compression ratio	9.0:1
Induction system	Electronic sequential multiple-port fuel injection
Fuel tank	15.4 gallons with tethered gas cap
Transmission	Standard 5-speed manual overdrive Optional automatic overdrive
Axle	Traction-Lok
Suspension, front	Modified MacPherson, nitrogen gas-pressurized hydraulic struts, variable rate coil springs, stabilizer bar
Suspension, rear	Variable rate coil springs, Quadra-Shock with vertically-mounted nitrogen gas-pressurized shocks, horizontally-mounted hydraulic with freon-filled bag axle dampers, stabilizer bar
Steering	Power rack-and-pinion, 14.7:1 on-center ratio
Brakes	Power front disc/rear drum
Wheels	15-inch cast aluminum (16-spoke style on GT; 10-hole style on LX 5.0L)
Tires	P225/60VR15 unidirectional Goodyear performance radials

MUSTANG LX

Engine type	2.3L OHC 4-cylinder
Compression ratio	9.5:1
Induction system	Electronic multiple-port fuel injection
Fuel tank	15.4 gallons with tethered gas cap
Transmission	Standard 5-speed manual overdrive Optional automatic overdrive
Suspension, front	Modified MacPherson, nitrogen gas-pressurized hydraulic struts, coil springs, stabilizer bar
Suspension, rear	Four-bar link, nitrogen gas-pressurized hydraulic shocks, coil springs
Steering	Power rack-and-pinion, 18.7:1 on center ratio
Brakes	Power front disc/rear drum
Wheels	Stamped steel, 14" x 5"
Tires	Standard P195/75R14 BSW steel-belted radials Optional P195/75R14 WSW steel-belted radials

SAFETY AND OWNER BENEFITS

Ford Motor Company strongly encourages all passengers to use their safety belts. In Mustang, a driver air bag supplemental restraint system is standard in all models.



Ford also urges the use of child and infant restraints, as required in all states. Ford's easy-to-install Tot-Guard (for children 20 to 50 pounds) is available at all Ford Dealers. If a child restraint requires a top- tether, Ford cars provide for attachment of an anchor at each rear outboard seating position (except Mustang Convertible models).

FORD LIFEGUARD DESIGN SAFETY FEATURES

Vehicle operation

- Split service hydraulic brake system with warning light
- Corrosion-resistant brake lines
- Flash-to-pass headlamps
- Turn indicator with lane-changing signal feature
- Hazard warning flasher
- Backup lamps
- Parking lamps coupled with headlamps
- High-mount brake lamp
- 2-speed windshield wipers with variable wipe
- Windshield washers
- Outside rearview mirrors
- Glare-reduced instrument panel, windshield wiper arms and windshield pillars
- Uniform transmission shift quadrant with safety starting switch (on all cars equipped with automatic transmission)
- Clutch or neutral interlock for starter motor (on cars equipped with manual transmission)
- Continuously variable control illumination intensity (instrument cluster lighting)
- Safety hood latch system
- Responsive windshield defroster system
- Tamper-resistant (non-reversing) odometer
- Speedometer with highlighted 55 mph
- Impact-activated fuel pump shut-off for electronic fuel-injected engines

Occupant protection

- Safety-designed front end structure
- Safety-designed roof structure on coupes, sedans and station wagons
- Steel guard rails in side doors
- Safety-designed door hinges and double yoke

- safety door latches
- Driver air bag supplemental restraint system with front outboard lap/shoulder belts and emergency locking retractors
- Integral lap and shoulder belts for occupants of rear seats
- Visual and audible seat belt fastening reminders for the driver's seat
- Energy-absorbing steering column and steering wheel
- Energy-absorbing armrests and safety-designed door handles
- Energy-absorbing instrument panel with padding
- Energy-absorbing sun visors
- Energy-absorbing front seat back tops
- Self-locking seat back latches
- Head restraints for front outboard occupants
- Safety glove box latch
- Inside yieldaway rearview mirror
- Impact-absorbing laminated safety glass windshield
- Flame-resistant interior materials
- Safety-designed coat hooks
- Safety-designed radio control knobs and push buttons

Anti-theft

- Locking steering column with audible key reminder
- Visible Vehicle Identification Number (VIN)
- Inside hood release

6-YEAR/60,000-MILE POWERTRAIN WARRANTY

Covers you and future owners, with no transfer cost, for 6 years or 60,000 miles, whichever comes first. This limited warranty covers major powertrain components. Ask your dealer for a copy of this warranty.

6-YEAR/100,000-MILE CORROSION PROTECTION

Mustang's corrosion warranty coverage for outer body panel rust-through is 6 years or 100,000 miles, whichever comes first. See your dealer for a copy of this limited warranty.

SCHEDULED MAINTENANCE

Here are some examples of normal scheduled maintenance intervals for the 1990 Mustang. For complete maintenance

recommendations, refer to the Maintenance Schedule and Record Log

Engine oil and filter change	7,500 miles or 6 months
Spark plug change	30,000 miles
Air filter replacement	30,000 miles
Engine coolant replacement	30,000 miles or 3 years

DAMAGE RESISTANCE

Ford equips Mustang with impact-resistant front and rear bumpers that meet the damageability requirements of the Federal Bumper Standards at 5 mph (exceeding the Standards' 2½-mph requirement).

FORD DEALER QUALITY COMMITMENT

The Ford Quality Commitment extends beyond the factory to every facility where Ford products are sold worldwide. Your dealer knows that making your satisfaction his top priority is part of the total team effort. To him, "Quality is Job 1," means putting the customer first.



Participating Ford Dealers offer the Lifetime Service Guarantee, which guarantees their customer-paid work on your Ford vehicle for as long as you own it. A covered repair is paid for once. If it ever has to be fixed again, the repairing dealer will fix it free. Ask to see a copy of the Lifetime Service Guarantee when you visit your participating Ford Dealer.



Optional Ford Extended Service Plans cover major components on new Ford cars and light trucks for longer than the vehicle's basic warranty. Your Ford Dealer has full details.

Motorcraft

QUALITY REPLACEMENT PARTS FROM FORD

Genuine Ford and Motorcraft original equipment replacement parts meet the same high standards as those installed in production.



The leasing alternative is available to qualified lessees through your participating Ford Dealer, who can arrange a Red Carpet Lease® tailored to your circumstances through Ford Credit. A wide variety of financing plans are also available.

OPTIONS AVAILABILITY

Options shown or described in this catalog are available at extra cost and may be offered only in combination with other options or subject to additional ordering requirements or limitations.

PRODUCT CHANGES

Ford Division reserves the right to change product specifications at any time without incurring obligations.

"ASK YOUR FORD DEALER"

Following publication of this catalog, certain changes in standard equipment, options, prices and the like, or product delays, may have occurred which would not be included in these pages. Your Ford Dealer is your best source for up-to-date information.

Best-Built American Cars.



This is based on an average of consumer-reported problems in a series of surveys of '81-'89 models designed and built in North America.