

F O R D 1 9 9 4

# PROBE





## 1994 PROBE GT

There are a great many sports coupes on the road, most of them quite ordinary. Then there are the few, the Ford Probe among them, that clearly stand apart from all the others in their class.

The inspiration and dedication of the car's designers, and their deeply intuitive sense for all the things that provide a truly rewarding driving experience — these are what ultimately generate the sense of excitement you get from the dynamics of the car's styling and its superb overall performance.

Probe is the product of a "customer-driven" design philosophy. This is a genuine sports coupe, the creation of men and women wholly committed to designing cars around your driving needs.

### THE PROBE GT. A STANDOUT IN ITS CLASS

The very look of Probe GT says driving enjoyment: The fluid contours of the sleek, aerodynamic body. The unique front and rear

fascia treatments, fog lamps, and lower bodyside cladding. And the low-profile, high-performance 16" tires.

But exciting power and exceptional handling are what make it all happen.

GT's responsive 24-valve, DOHC, multi-port fuel-injected 2.5-liter V-6 puts out 164 horsepower (SAE rating) @ 5,600 rpm and 160 lbs.-ft./torque @ 4,000 rpm.

The 4-wheel independent suspension system with sport-tuned components and the low-profile, wide-stance P225/50VR16 radials deliver tight handling capability. And GT is equipped with 4-wheel disc brakes, to which you can add the optional anti-lock system.

GT is designed for driving comfort, too, with a multi-adjustable driver's seat, full center console, and more.

And because safety is such a high priority, Probe for 1994 comes equipped with an air bag supplemental restraint system for both the driver and front passenger.



*Probe GT in Rio Red Tinted Clearcoat, pictured also at right. Some equipment shown is optional.*









# PROBE ERGONOMICS

In a superbly crafted sports coupe, the attributes of style and function are as important to interior design as they are to the shape of the aerodynamic body shell.

## SUPERB ERGONOMICS

Notice how the Probe's instrument and door panels are smoothly integrated, as though they're a single piece. Take note, too, of the center console angled toward the driver's seat — a design that is not only pleasing to the eye, but helps make operating the car convenient.

Seating is body-contoured for comfort. The shift lever is carefully located in relation to the driver's position. Important operating information on the driver-oriented instrument panel is located directly in your line of sight beneath a low windshield cowl line. The instrument cluster features the clarity of analog gauges, including a tachometer, fuel gauge, engine coolant temperature gauge, oil pressure gauge, and voltmeter.

The controls, some on steering column levers, are easy to reach and operate so that you can concentrate your attention on the road.

When you drive as comfortably and conveniently as you do at the wheel of a Ford Probe, you're in full command of the car and the road. Which is the ultimate goal of the engineer in the design of a performance car.



On the center panel console are heating/cooling, stereo system and other controls. As you can see in the photograph at right, this console is angled toward the driver, an important ergonomic design feature.

## DUAL AIR BAGS STANDARD

Probe is designed not only for your driving enjoyment, but for your safety as well.

Probe's "operating safety" features — the suspension, steering and braking systems, for example — can help you avoid an accident. And there are the "occupant safety" features designed to protect you in the event of an accident. Especially important is

the air bag supplemental restraint system. In Probe for 1994 it's standard equipment for both the driver and the front passenger.

Today, Ford has more cars equipped with dual air bags than many other manufacturers. But important as the air bag is, it's intended only to supplement your lap and shoulder safety belts, so be sure always to buckle up.



Above: Probe GT interior in Opal Grey. Driver seat power lumbar/seat back bolster adjust, a leather-wrapped steering wheel and manual transaxle shift lever are GT standard features.

Left: An air bag supplemental restraint system is standard for both the driver and front passenger in Ford Probe for 1994. Be sure always to buckle up your safety belts.

Some equipment shown on these pages is optional.



Dual electric remote mirrors are included in all Preferred Equipment Packages. Heated mirrors are included with the optional rear wiper/washer.

A "memory" feature returns your forward-folded seat back to the exact position you previously set.

Headlamps, turn signals and wiper/washer controls are on steering column-mounted levers.

50/50 split rear seat backs can be lowered individually, allowing for added luggage or cargo either with or without a third passenger.



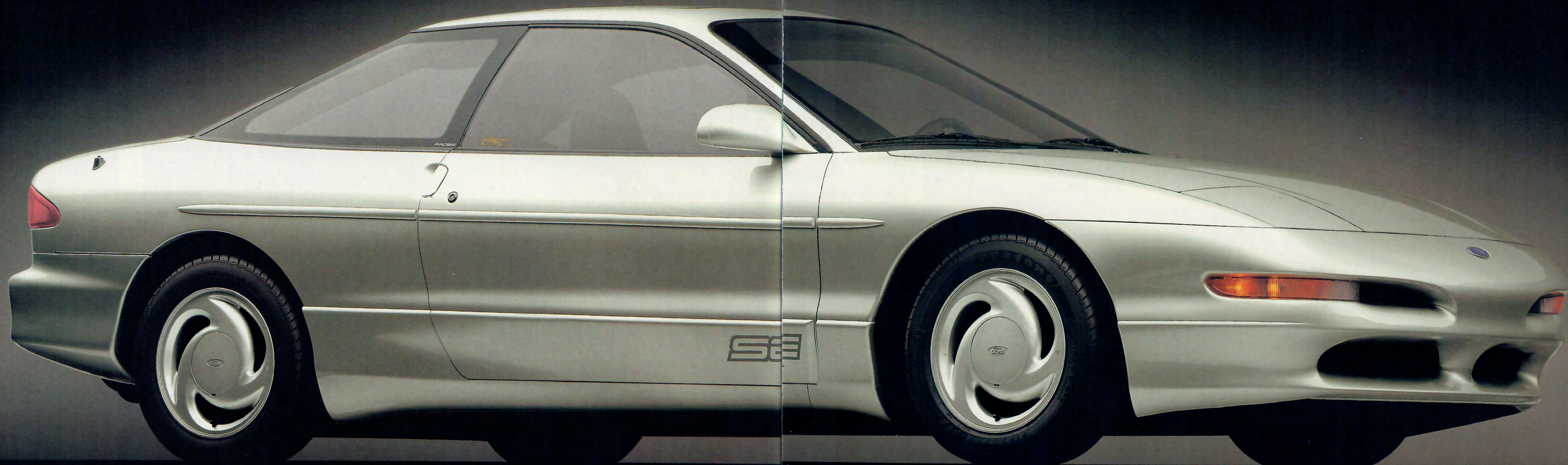

## PROBE

When it comes to getting down to the serious business of what driving enjoyment is all about, Probe is quite a capable performer.

With its 4-wheel independent suspension system and 16-valve, DOHC 2.0-liter engine, Probe can generate a lot of driving fun.

And playing no small part in Probe's excellent overall

performance is a beautifully sculpted aerodynamic shape that cheats the wind and its performance-robbing effects.

An aerodynamic design requires less horsepower to overcome the inhibiting force of air drag at cruising speeds.

Also, air flow is redirected over the body in such a way as to increase downforce on the tires for better handling.

Probe sports a great list of standard features, such as body-contoured bucket seats, the clarity of analog gauges, an electronic AM/FM stereo sound system, and versatile 50/50 split fold-down rear seats, to mention just a few.

And Probe 1994 comes equipped with an air bag supplemental restraint system for both the driver and the

front passenger. Be sure always to buckle up your lap/shoulder safety belts.

You'll find a lot of superb options, too, for personalizing your Probe. Power sliding roof. Anti-lock brake system with sport suspension. Full center console. CD player with subwoofer. All-electronic 7-band graphic equalizer. And the exciting Sport Edition.

*Probe in Aspen Silver Clearcoat Metallic with the optional Sport Edition: GT front fascia (without fog lamps), GT body-color bodyside cladding, 15" aluminum wheels, P205/55R15 87S BSW tires, and Sport Edition "SE" nomenclature.*

*Following pages: Probe in Portofino Blue Clearcoat Metallic.*

*Some equipment shown on these pages is optional.*







## SAFETY AND HANDLING

Virtually eliminated is the tendency to pull in a particular direction when hard acceleration is applied — a condition known as “torque steer.”

Probe responds precisely to driver inputs in highway-speed maneuvering as well as in lower-speed cornering. The quadra-link rear suspension system, for example, is designed to offset the car's tendency to “toe-out” under the forces of acceleration, cornering and braking by eliminating toe change.

Excellent road-holding is the result of integrated systems components: Tuned strut valving, bushings, spring rates, and stabilizer bars. The quadra-link rear suspension design. Plus low aspect-ratio tires.

With its sport-tuned suspension components and low-profile 16” performance radials, the GT takes Probe's excellent handling capability to even greater heights of high performance.

Probe is engineered on a total performance concept whose singular purpose is to reward the driver.

It's an approach that's fully driver-oriented in its focus: Every aspect — power, handling, steering and braking — is viewed not as a distinct element, but rather as part of a total, integrated equation.

### TIGHT HANDLING, PRECISE STEERING

Probe features a 4-wheel independent suspension with MacPherson struts/coil springs. The stabilizer bars, strut valving, spring rates and bushings are tuned for balanced ride quality and tight, solid handling.

Front suspension tuning, steering geometry, and the half-shafts of equal length work together to virtually eliminate the condition known as “torque steer” — the car's tendency to pull in a particular direction when hard acceleration is applied.

The quadra-link rear system is designed to offset the natural inclination of the wheels to “toe-out” under the forces of acceleration, cornering and braking (which can reduce stability and control) by eliminating

toe change. This design enables the wheels to maintain their effective alignment for enhanced sensitivity to directional changes.

Probe has the traction of front-wheel drive. The rack-and-pinion power steering system is precise, with a firm “on-center” feel.

### RESPONSIVE BRAKING

The power brakes are responsive and resistant to fade. And for world-class stopping capability, there's the optional 4-wheel disc anti-lock brake system.

The computerized anti-lock brake system prevents the wheels from locking up in a hard braking situation or on slippery roads by applying and releasing the brakes at a rate of speed far exceeding that of human capability — up to 10 times per second. It's much like a professional driver who skillfully “pumps” the brakes, only a great deal faster.

Anti-lock braking helps provide greater steering control and smooth, straight stops under most conditions.

In Probe you have a complete handling system that perfectly complements the power under the hood.



The standard Probe has power-assisted front disc/rear drum brakes. The Probe GT comes with 4-wheel discs. A computer-controlled anti-lock system is available in both models.

“Operating safety” features (steering, suspension and brake systems, for example) are engineered to help you avoid an accident. And there are “occupant safety” features (such as the air bag supplemental restraint system) that are designed to provide protection in the event of an accident.





# PERFORMANCE

Sport performance is yours to enjoy with the responsive 2.0-liter I-4 in Probe or the 2.5-liter V-6 under the hood of the exciting Probe GT.

Though comparatively small in their displacements, each of these multi-valve engines delivers excellent all-around performance.

Especially impressive is the Probe GT's V-6, which is but 2.5 liters in size yet is surprisingly powerful. It has exceptional power-efficiency as well: a high ratio of power (164 SAE net hp) to displacement (153 cu. in.). That's more than one horsepower per cubic inch.

## MULTI-VALVE DESIGN

Both powerplants employ multi-valve technology long embraced by designers of racing engines as one of the best ways to increase power output without having to increase displacement.

Each cylinder has four valves (two for intake and two for exhaust) and belt-driven twin overhead camshafts (one activating the intake valves and the other the exhaust valves). Into each cylinder is injected as much fuel/air as possible, and as quickly as possible.

The basic objective in the multi-valve design is to extract optimum power from every drop of fuel and to deliver responsive power and torque over the full performance range — from accelerating off the line to passing at highway speed.

The freer-breathing four valves (versus two) increase the flow and velocity of air into and out of the cylinder, promoting greater rapid-burn combustion and delivering higher power output. And the valves, each smaller and lighter, permit the use of low-tension springs, enabling the engine to reach higher rpm more quickly.

## MULTI-PORT FUEL INJECTION

Integral to the success of the multi-valve design is a "multi-port" electronic fuel-injection (EFI) system that is governed by a computer.

Multi-port EFI delivers an electronically controlled, precisely measured amount of fuel into each cylinder, which has its own injector. Precise fuel metering promotes clean, even burning of the fuel. And, especially important, it helps improve efficiency\* while increasing power and response.

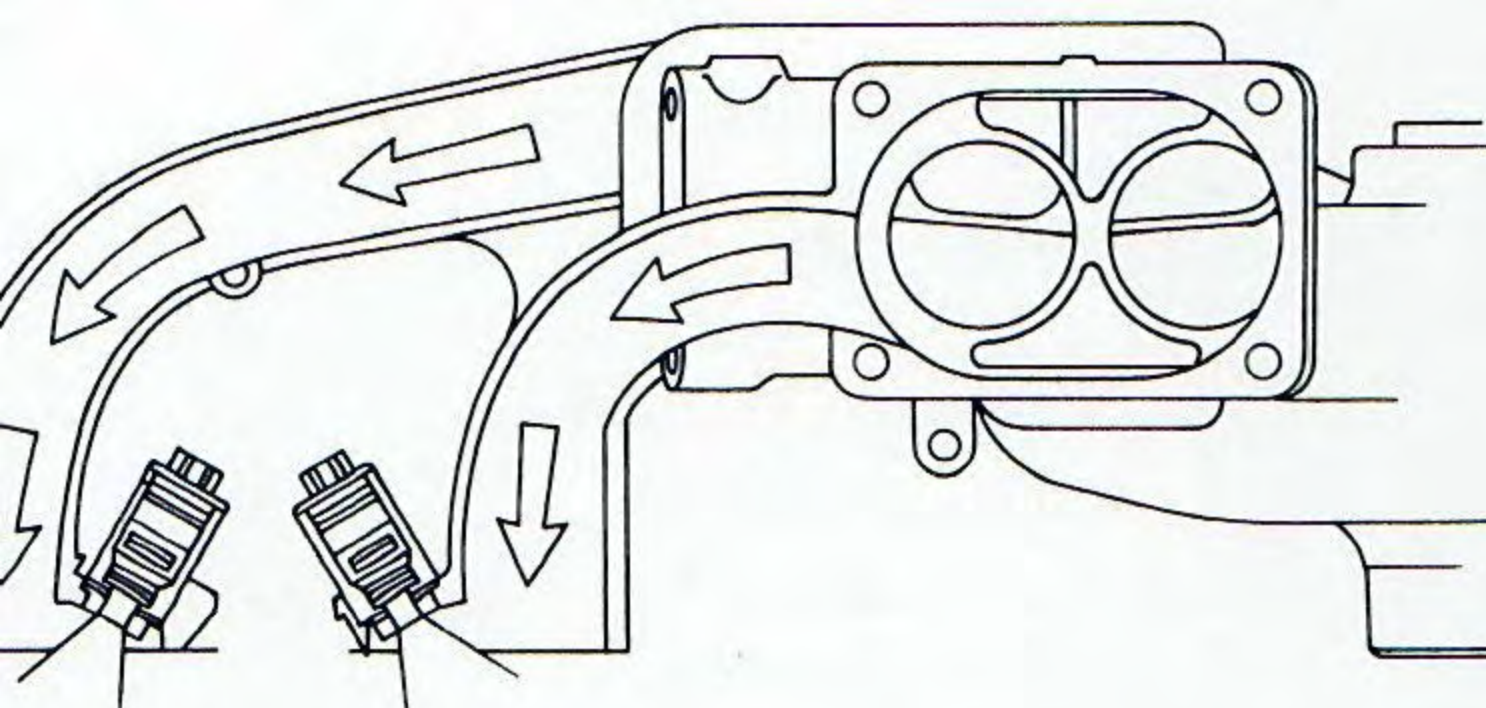

Computer-controlled, multi-port electronic fuel injection provides precise fuel metering for efficiency\* and smooth operation.

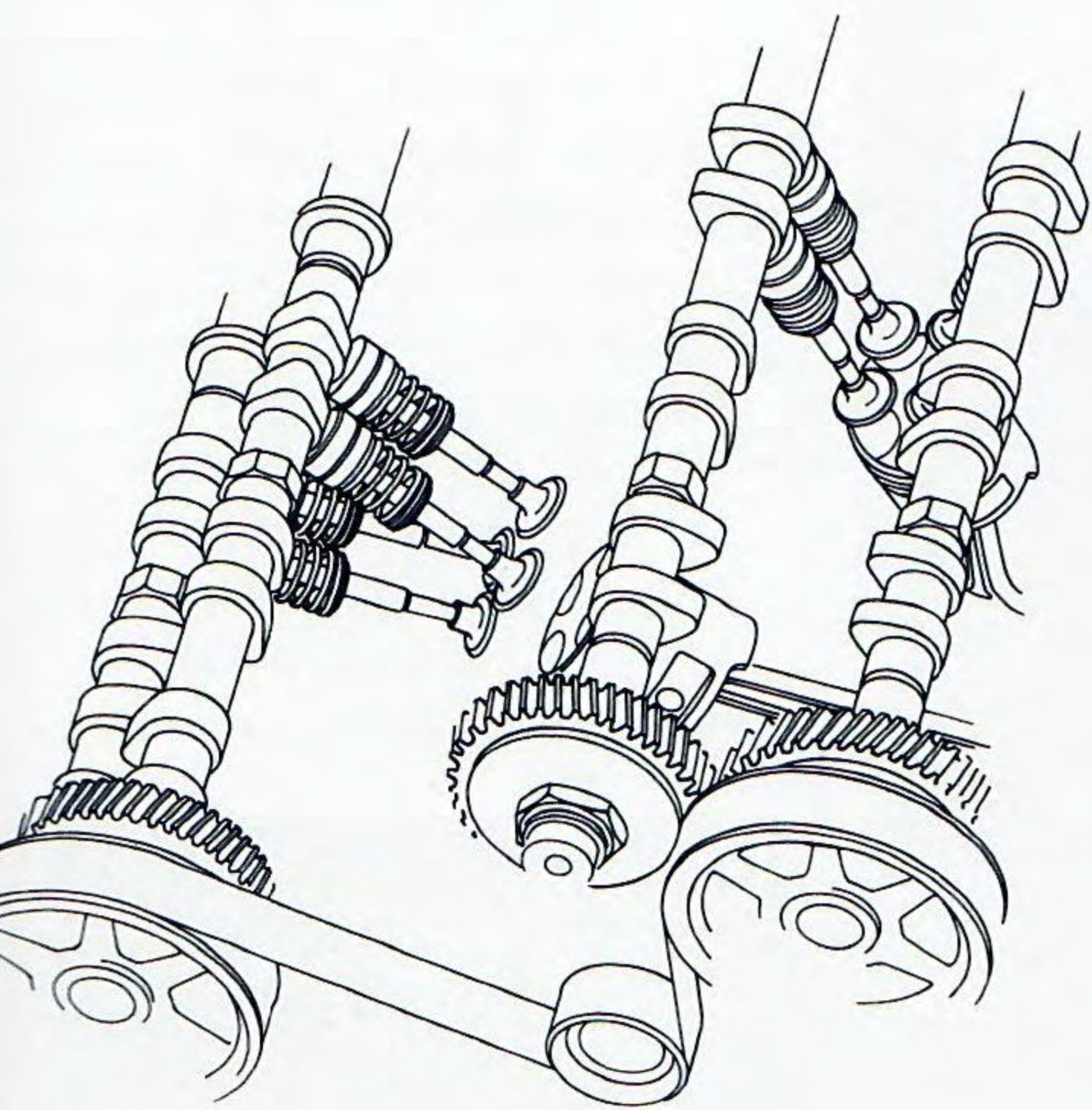

Four valves per cylinder (two for intake, two for exhaust), actuated by belt-driven dual overhead camshafts, promote high-flow/velocity breathing and rapid-burn combustion.

\*EPA estimates were unavailable at press time. See your Ford Dealer for mileage information.

Probe GT's 24-valve, DOHC, multi-port fuel-injected 2.5-liter V-6 puts out 164 horsepower (SAE rating) @ 5,600 rpm and 160 lbs.-ft. torque @ 4,000 rpm.

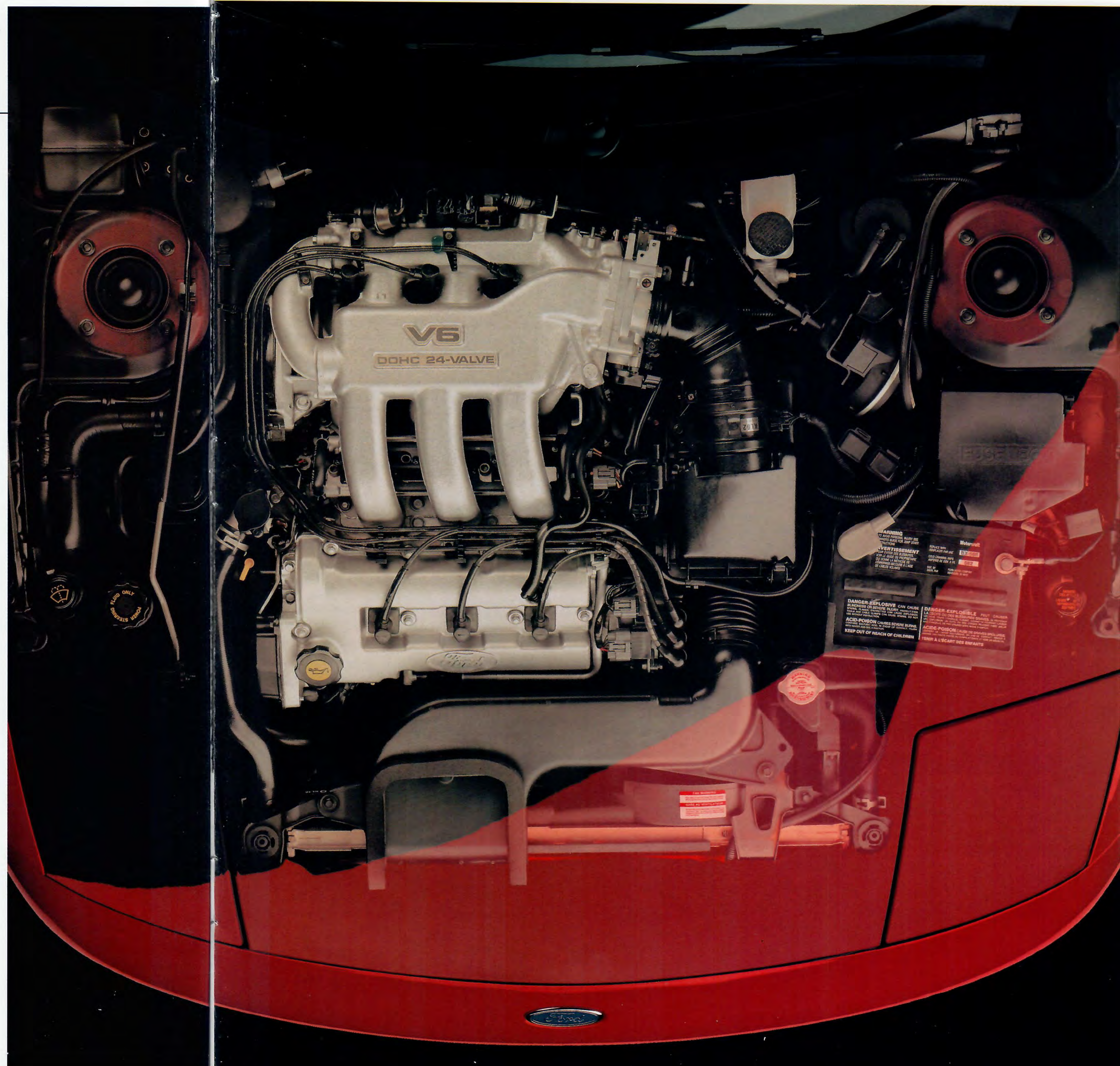



# STANDARD FEATURES AND OPTIONS

## PREFERRED EQUIPMENT PACKAGES AND OPTIONS

P = Package feature (content subject to change)  
O = Optional feature S = Standard feature

	Probe		Probe GT	
	251A	253A	261A	263A
Group 1: Rear window defroster; dual electric remote-control mirrors	P	P	P	P
Group 2: Tilt steering column; convenience group (tinted glass, interval windshield wipers, remote fuel door/liftgate releases, battery saver, headlamp warning chime, door/liftgate ajar light, low fuel light, low washer fluid light, glove box light, underhood light, and fade-to-off dome lamp)	P	P	P	P
Group 3: CFC-free air conditioning; electronic AM/FM stereo radio with cassette player, digital clock and premium sound system	O*	P	P	P
Group 4: Color-keyed bodyside moldings (may be deleted); speed control; light group (illuminated entry system, dual illuminated visor vanity mirrors, remote keyless entry system; and fade-to-off dome lamp with map lights); power group (power side windows with driver and passenger "express-down" feature operated from the driver's seat, and power door locks)	O*	P	O*	P
Group 5: Anti-lock braking system (includes 4-wheel disc brakes and sport suspension system in Probe model); rear wiper/washer and heated dual electric remote-control mirrors	O*	O*	O*	P
Electronic 4-speed automatic transaxle (requires optional anti-lock braking system in GT model)	O	O	O	O
Leather seating surfaces on front bucket seats only	-	-	O	O
Manual driver's seat height adjustment	O	O	-	-
Power driver's seat	-	-	O	O
Console with storage armrest/cupholder	O	O	S	S
Front color-keyed floor mats	O	O	O	O
Anti-theft system	O	O	O	O
Electronic AM/FM stereo radio with compact disc player, digital clock, and premium sound system with subwoofer speaker	O	O	O	O
All-electronic 7-band graphic equalizer	O	O	O	O
Power radio antenna	-	O	O	O
Engine block heater	O	O	O	O
Power sliding roof (includes dome lamp/map lights)	O	O	O	O
15" aluminum wheels and P205/55R15 BSW tires	O	O	-	-
SE option: GT front fascia (without fog lamps), GT body-color bodyside cladding, unique 15" aluminum wheels, P205/55R15 black sidewall tires, and Sport Edition "SE" nomenclature	O	O	-	-
Feature car: includes Wild Orchid exterior paint, unique floor mats, and black GT cloth bucket seats with unique inserts	-	-	O	O

\* All features listed in the group are available individually.

## PROBE PAINT AND TRIM COLORS

Exterior Paint Colors	Interior Trim Colors			
	Opal Grey	Black	Ruby Red	Royal Blue
Rio Red Tinted Clearcoat	■	■	■	
Coral Mist Clearcoat Metallic	■	■	■	
Electric Red Clearcoat Metallic	■	■	■	
Wild Orchid Clearcoat Metallic	■	■	■	
Portofino Blue Clearcoat Metallic	■	■	■	■
Electric Blue Clearcoat Metallic	■	■	■	■
Teal Mist Clearcoat Metallic*	■	■	■	
Aspen Silver Clearcoat Metallic	■	■	■	
Black Clearcoat	■	■	■	■
Vibrant White	■	■	■	■

\*Late availability. See your dealer for details.

## MAJOR STANDARD FEATURES

### Probe

- Concealed halogen headlamps
- Manual-adjustable outside mirrors (driver-side remote)
- Flush door handles
- Wraparound quarter windows with concealed center and rear pillars and flush glass
- Tinted rear window and quarter window glass
- Functional roof drip molding
- Wheel covers
- Air bag supplemental restraint system for driver and front passenger
- 3-point lap/shoulder safety belts front and rear
- Electronic AM/FM stereo radio, digital clock, 4 speakers
- Center console with rear ashtray
- Side window demisters
- Performance instrument cluster with tachometer, fuel gauge, temperature gauge, oil pressure gauge, voltmeter, and trip odometer
- Urethane soft-feel steering wheel
- Cloth bucket seats with integral headrests; recliners with memory feature
- Door trim panels with integral armrests
- 50/50 fold-down rear seats
- Cargo compartment light

### Probe GT (in addition to or in place of standard Probe features)

- Unique front and rear fascias
- Rectangular fog lamps
- Lower bodyside cladding
- 16" 5-spoke aluminum wheels
- Full center console with armrest and cup holder
- Leather-wrapped steering wheel and manual transaxle shift knob
- GT cloth bucket seats with driver-side power lumbar/seat back side bolster adjust
- Seat back stowage compartment
- Cargo area net

## PRODUCT CHANGES

Following publication of the catalog, certain changes in standard equipment, options, prices and the like, or product delays, may have occurred which would not be included in these pages. Your Ford Dealer is your best source for up-to-date information.

Ford Division reserves the right to change product specifications at any time without incurring obligations.

Optional speed controls are located on the steering wheel for fingertip convenience.



Let in more sunshine and fresh air with the optional power sliding roof.

For added security, Probe offers an optional remote keyless entry system.



Enhance rearview vision year-round with the optional rear wiper/washer and electric heated remote-control mirrors.



Enjoy the superb quality and performance of the optional compact disc player with electronic AM/FM stereo radio, subwoofer speaker, and amplifier putting out 140 watts of power.

The 7-band graphic equalizer has five pre-set memories (classical, pop, rock, vocal and jazz) and many other outstanding features.



Left to right: 14" wheel covers (standard on Probe); 15" 3-spoke aluminum wheels (optional on Probe), and 16" 5-spoke aluminum wheels (standard on GT).



# PROBE SPECIFICATIONS

## Engine, Probe

Type	I-4
Valves	16, DOHC
Displacement	2.0L (122 cu. in.)
Horsepower (SAE net)	118 @ 5,500 rpm
Torque (SAE net lb.-ft.)	127 @ 4,500 rpm
Fuel system	Multi-port electronic fuel injection

## Engine, Probe GT

Type	V-6
Valves	24, DOHC
Displacement	2.5L (153 cu. in.)
Horsepower (SAE net)	164 @ 5,600 rpm
Torque (SAE net lb.-ft.)	160 @ 4,000 rpm
Fuel system	Multi-port electronic fuel injection

## Transaxle

Type	5-speed manual overdrive (std.) Electronic 4-speed automatic (opt.)
------	--

## Body/Chassis

Drivetrain type	Front-wheel drive
Body type	Unitized with separate front subframe
Front suspension	Independent MacPherson struts with stabilizer bar (unique sport handling components in GT)
Rear suspension	Independent MacPherson struts with stabilizer bar (unique sport handling components in GT)

## Body/Chassis, cont'd

Steering	Power rack-and-pinion, 17:1 overall ratio
Brakes	Power front disc/rear drum Power 4-wheel disc (GT)
Tires	P195/65R14 88S BSW all-season P225/50R16 91V BSW performance (GT)
Fuel capacity	15.5 gallons

## Dimensions

	2-Door Probe/Probe GT
Wheelbase	102.9"
Length	178.9"
Height	51.6"/51.8"
Width	69.8"
Front tread	59.8"/59.4"
Rear tread	59.8"/59.4"
Front head room	37.8"
Rear head room	34.8"
Front leg room	43.1"
Rear leg room	28.5"
Front shoulder room	51.9"
Rear shoulder room	53.8"
Cargo volume (cu. ft.)	11*
Passenger capacity	4

\*With rear seat backs up.

## BUMPER-TO-BUMPER COVERAGE

The 36-month/36,000-mile bumper-to-bumper coverage of Ford's new vehicle limited warranty covers the complete vehicle (except tires, battery, service adjustments and other items covered under separate provisions) against defects in factory-supplied materials or workmanship. For complete information, see your dealer.

## FORD CITIBANK CREDIT CARD

Using your Ford Citibank Visa® or MasterCard® could earn you hundreds, even thousands of dollars from Ford toward the purchase or lease of a new Ford, Lincoln or Mercury product. To apply or get more information, call

1-800-374-7777. Or visit a Ford or Lincoln-Mercury Dealer, or a branch office of Citibank.

## ROADSIDE ASSISTANCE PROGRAM

Every new Ford includes the assurance of an emergency Roadside Assistance Program provided by Ford Auto Club, Inc. during the 3-year/36,000-mile bumper-to-bumper warranty period. Help is a toll-free phone call away 24 hours a day, anywhere in the continental United States should you need any towing assistance, fuel delivery, tire change, a jump start or even help when you're locked out of your car. Ask your Ford Dealer for complete details on the Ford Roadside Assistance

Program and a copy of this limited warranty.



Optional Ford Extended Service Plans can cover major components on new Ford cars and light trucks for longer than the vehicle's basic warranty. Your Ford Dealer has full details.



Ford Credit is a full service company that makes a wide variety of financing and leasing programs available to qualified buyers through the Ford Dealer of your choice. Through Ford Credit's financing or Red Carpet leasing, arrangements suited to your

special needs can be made quickly and conveniently right at the dealership. Ask your Ford Dealer for the facts on any of Ford Credit's financing or lease plans.

## OPTIONS AVAILABILITY

Options shown or described in this catalog are available at extra cost and may be offered only in combination with other options or subject to additional ordering requirements or limitations.



Printed on recycled paper  
10% post-consumer waste

