

TAURUS

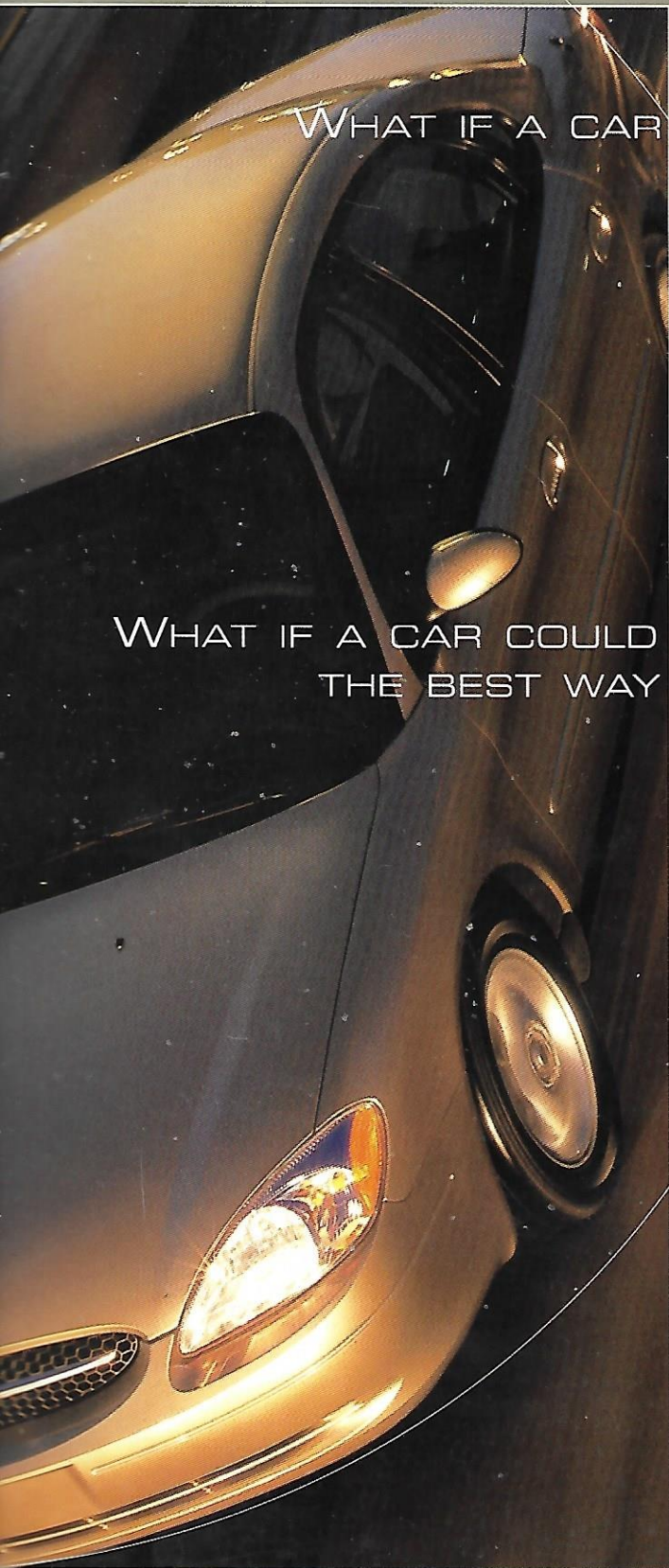

2000 TAURUS



WHAT IF A CAR COULD SEE WHAT YOU SEE?

WHAT IF A CAR COULD DETERMINE
THE BEST WAY TO PROTECT YOU?

WHAT IF?

WHAT IF?

Can anyone really expect to answer the question?

Not likely.

At Ford, curiosity has always been the clearest path to innovation.

Or in this case, reinvention.

From the clever Personal Safety System down to the way we

approach a cupholder, the new 2000 Taurus is surprisingly resourceful.

Surprisingly adjustable. It's our way of making a design statement.



Child seat

tether anchors

Child safety seat tether anchors help enhance child protection.

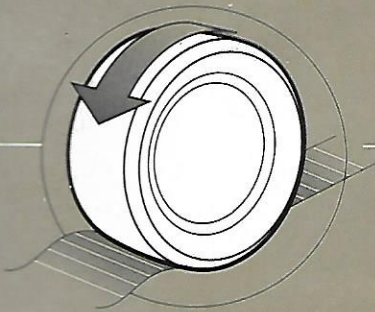

Traction Control

Taurus can now be equipped with an All-Speed Traction Control System. Traction Control works to detect and limit wheel spin to help drivers maintain traction on slippery surfaces. At all speeds.

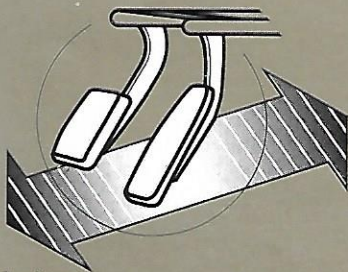

Class-exclusive power adjustable pedals

Class-exclusive power adjustable pedals allow smaller drivers to sit a comfortable distance from the steering wheel.

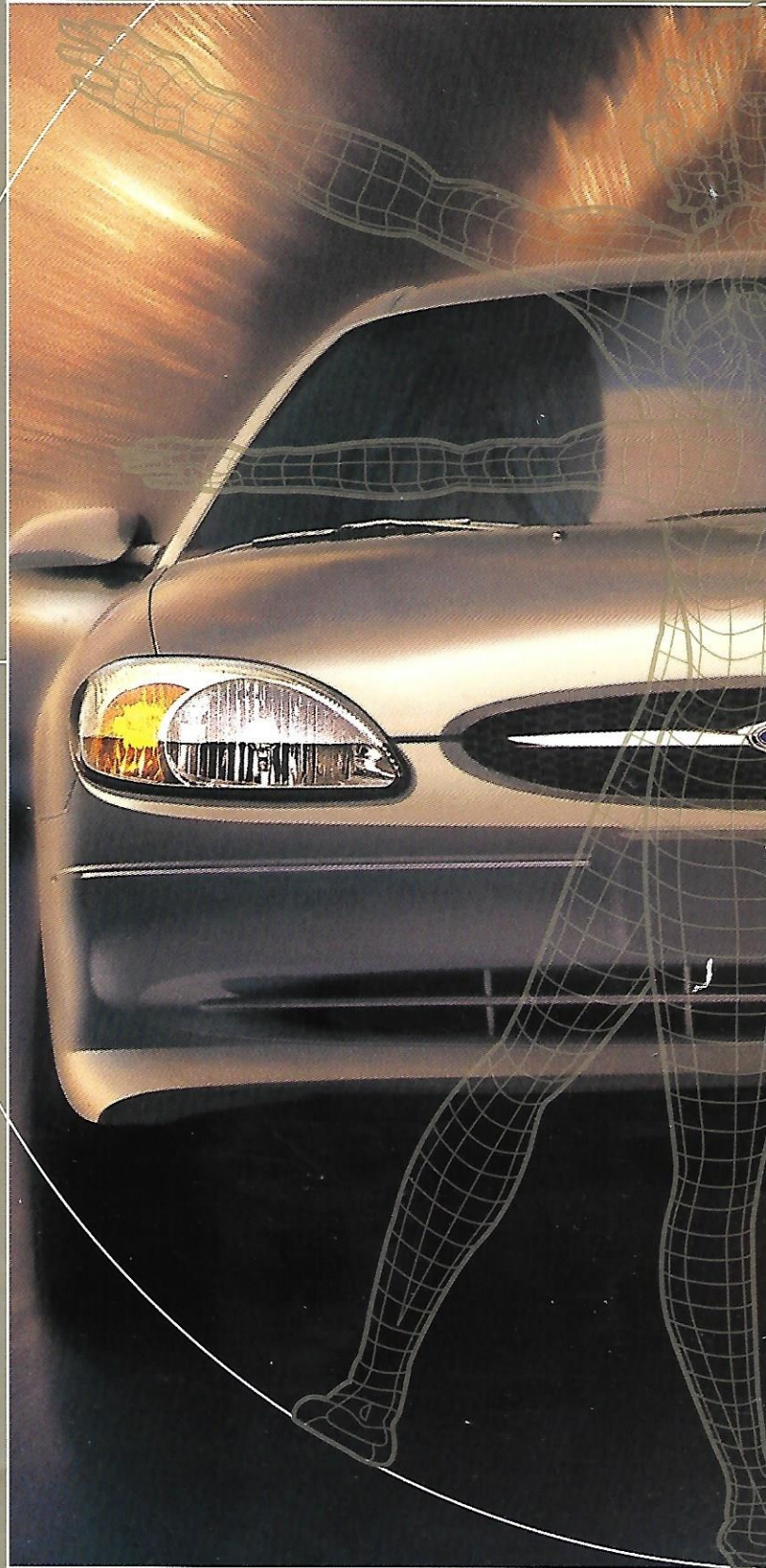

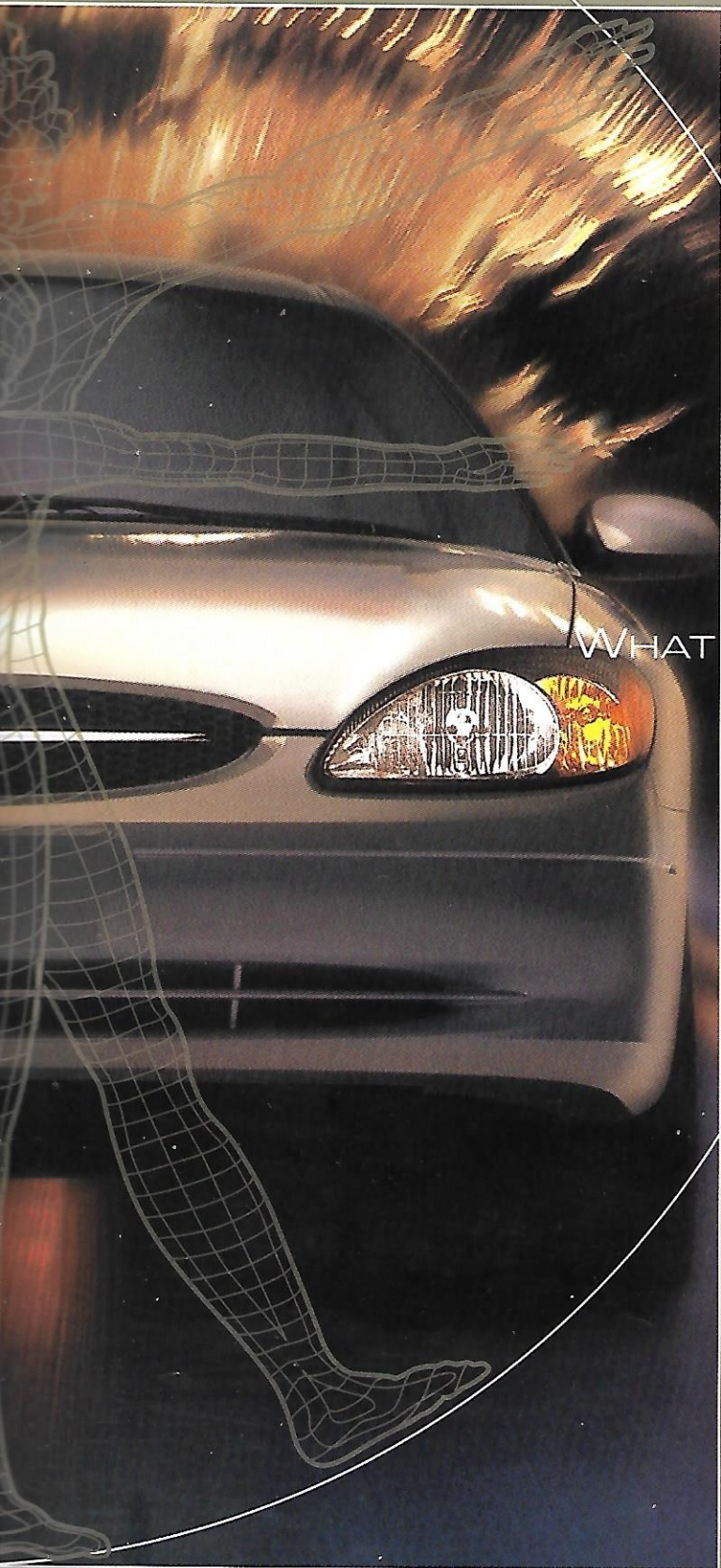

WHAT IF A CAR COULD ADJUST TO YOU?

Dual-stage airbags

Dual-stage airbags deploy in a manner that corresponds to crash severity. Lower, less forceful inflation for moderate impacts and higher inflation for severe impacts.

Always wear your safety belt and secure children in the rear seat.

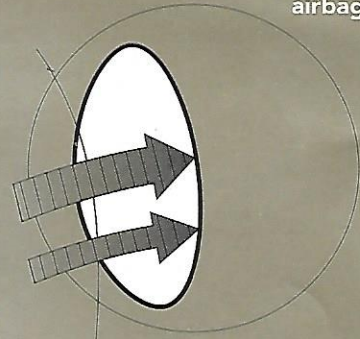

Side-impact airbags

Optional front seat side airbags deploy independently during side impacts. They are designed to help reduce injury to the head and chest.

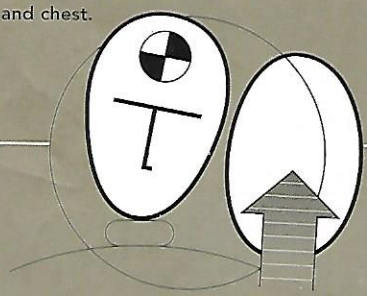

Manual lumbar feature

The new manual lumbar feature on the driver's seat is arched to provide more comfort to a wider range of drivers. Opt for the power driver's seat for easier adjustment and a more ergonomic driving position.

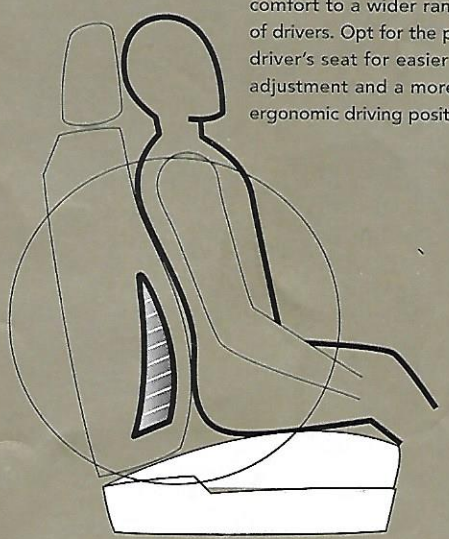

WHAT IF A CAR COULD DETERMINE THE BEST WAY TO PROTECT YOU?

The Personal Safety System.

For the first time in Ford history, a computer-driven system that "thinks" and responds to different crash conditions.

Within milliseconds of a crash, sensors feed information about the driver's seating position, safety belt usage, and crash severity to the Restraints Control Module – the "brain" of the system. This customizes protection, allowing appropriate safety technologies to operate during a frontal collision. For instance, in moderate severity crashes or for drivers sitting close to the steering wheel, the Personal Safety System deploys airbags with lower force.

In more severe crashes, airbags deploy with a higher inflation rate. The System can also activate safety belt pretensioners, which tighten to hold belted passengers securely during a crash. And energy management retractors "smooth" a person's forward momentum to help reduce the risk of chest injury.

SAFETY

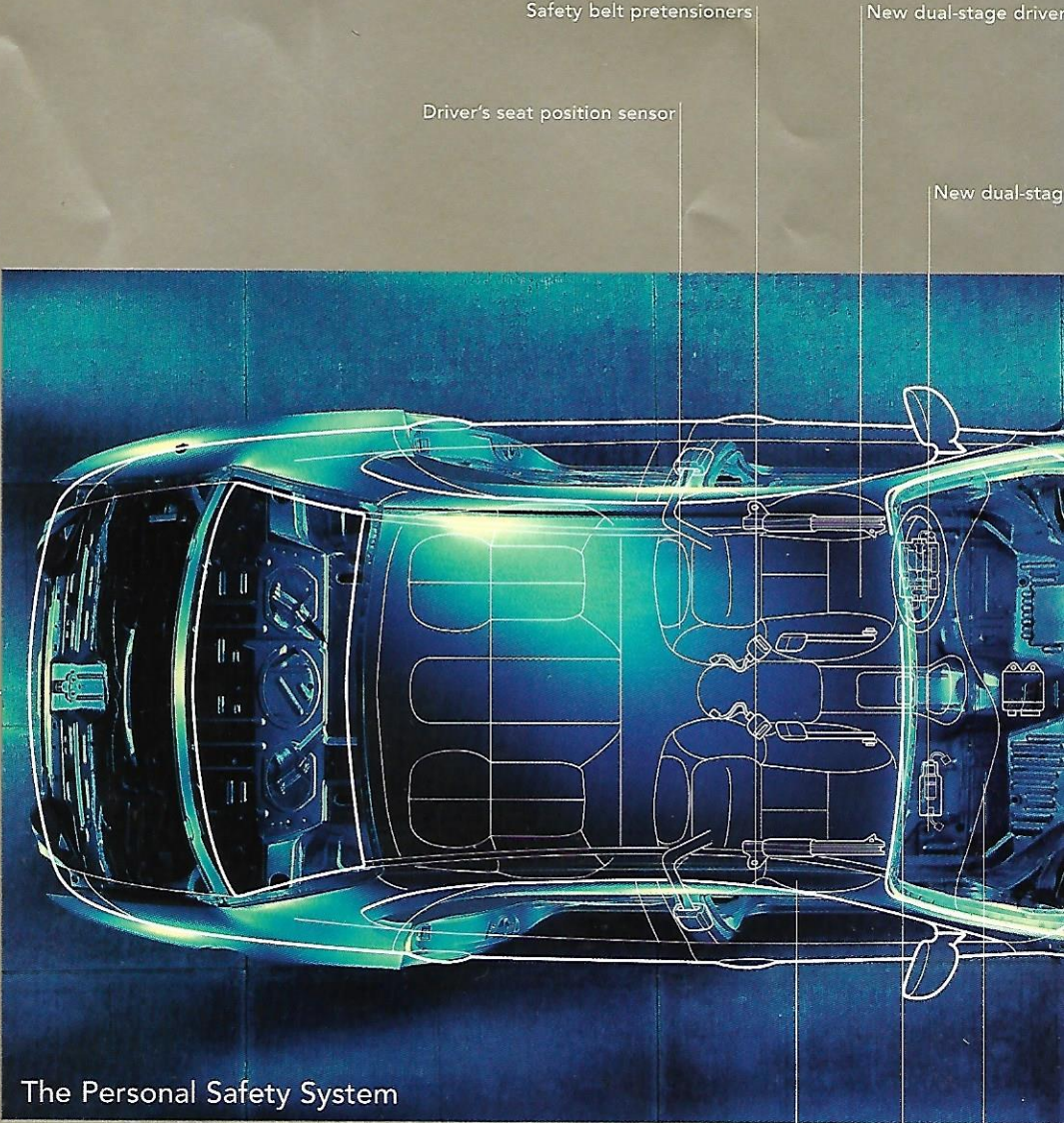

Safety belt pretensioners

New dual-stage driver

Driver's seat position sensor

New dual-stage

The Personal Safety System

Front safety belt usage sensors

Energy m

Personal Safety System Restraints Control Module

crash severity sensor

airbag



The new Taurus is 30% quieter than before. Noise entering the car is soaked up by new lightweight dash insulation, a heavier carpet barrier and a fully lined trunk. We even flared the edge of the hood so wind sweeps more silently over the car.

Emergency interior trunk release with a glow-in-the-dark handle puts safety within easy reach.



tractors

The trunk opening is wider than before for easier loading. It's also equipped with utility hooks to keep things in place.

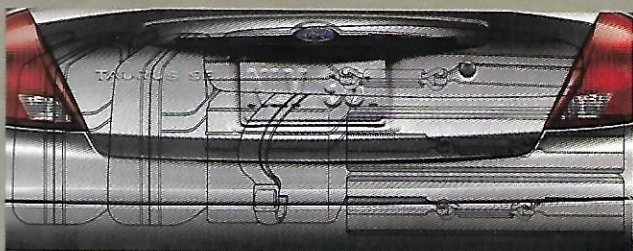

Inside the 2000 Taurus there is purpose behind every change we made. It can be as subtle as controls that are easier to grip. Or up to seven conveniently placed map pockets. Of course, it may also be significant. A roofline raised, from front to back, to improve head room for up to six passengers. Purposeful innovation. It's the only reason to change.

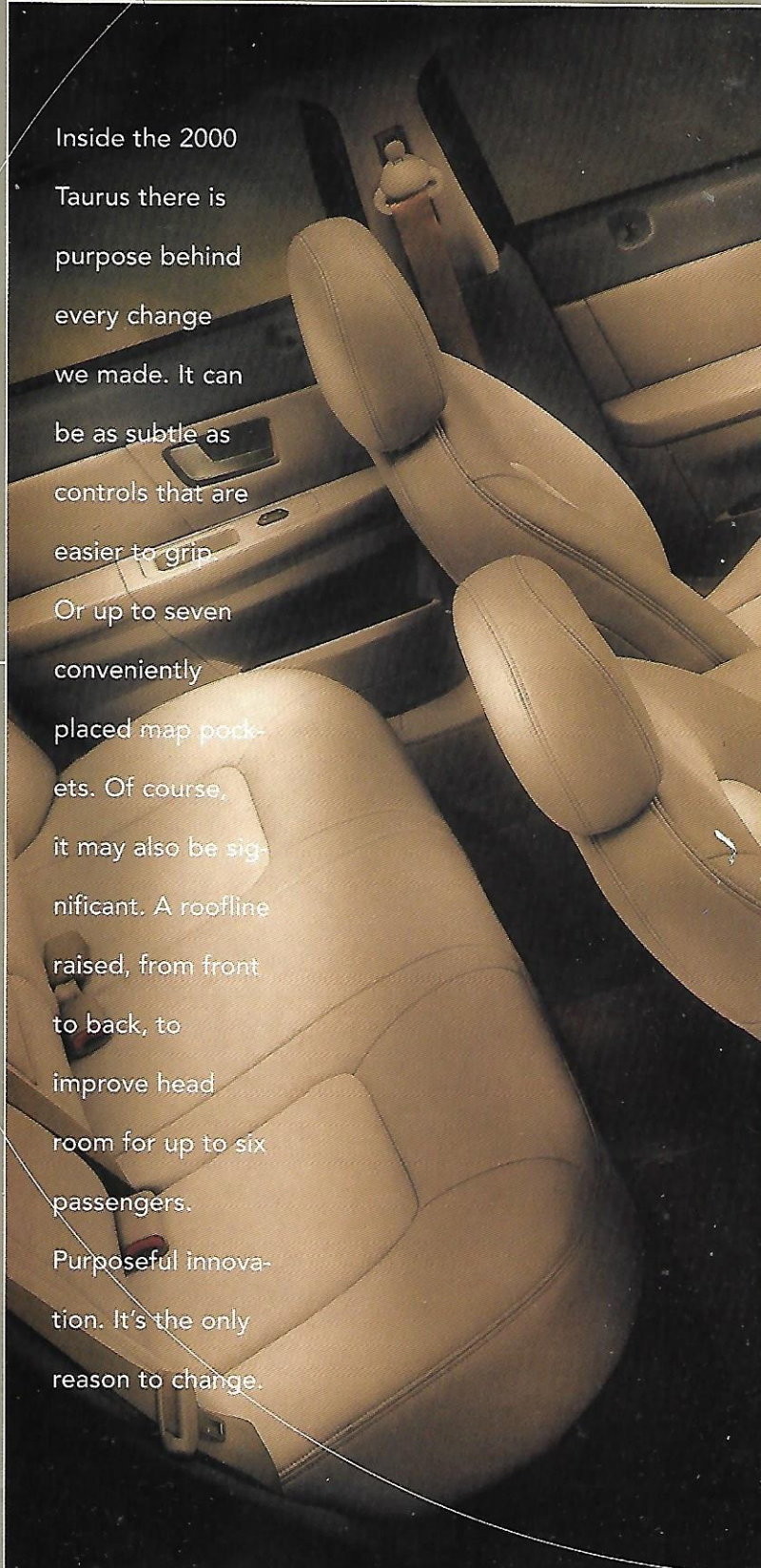



What is a standard-sized drink? The answer: There isn't one. We kept this in mind when we developed an adjustable cupholder that actually works. Refreshing, indeed.

Even the A-pillar was improved. Energy-absorbing foam padding was added to help lessen the risk of a head injury during a crash.

Dual front powerpoints let you run more than one accessory at a time. Standard.



The new flip/fold center console* opens flat to provide additional storage space and beverage holders. The console is such a smart use of space, it's patented.

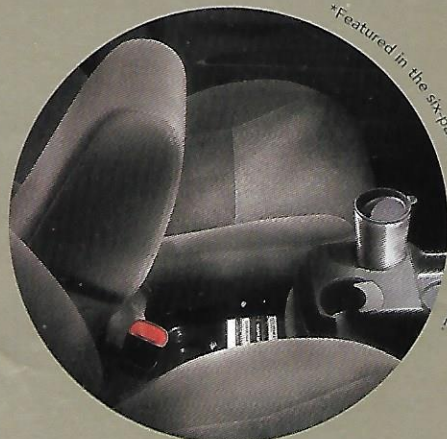

*Featured in the six-passenger[†] Taurus LX and SE



An environmentally responsible flexible-fuel version of the Taurus engine is standard with LX and available with SE and SES. This engine is equipped with a larger 18-gallon fuel capacity. More importantly, it runs on renewable ethanol-based fuel, 100% gasoline, or a mixture of the two.

DURABILITY

The best way to determine a car's durability is to put it through its paces. With Taurus, this meant logging over four million real world miles.

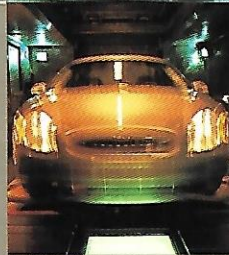
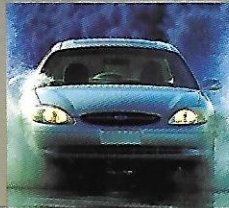

The 4-Post Shaker simulates 150,000 miles of the worst washboard road imaginable. A rather vigorous way to test for squeak and rattle. The simulator is also capable of testing under extreme weather conditions. Inside, temperatures dip as low as -30° F and rise as high as 180° F.

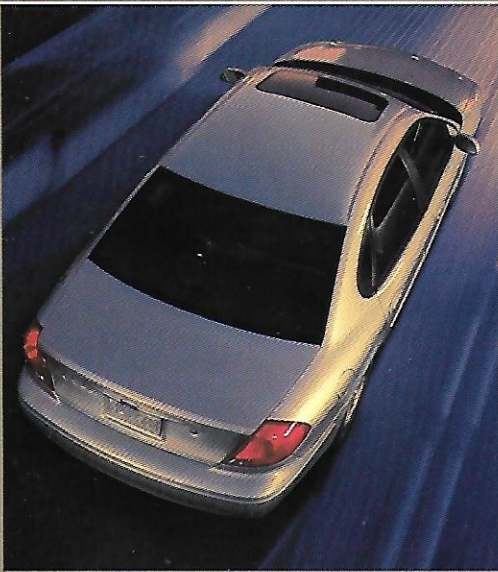
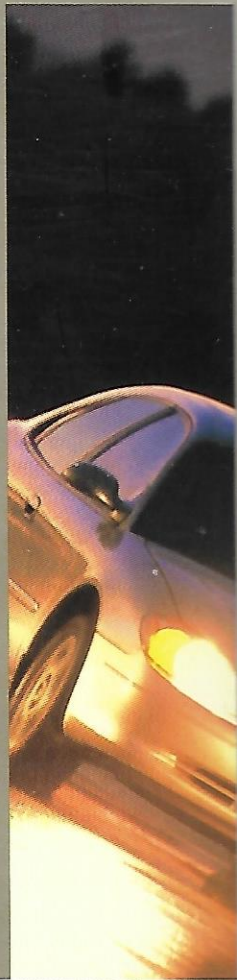

It's up to you. Better yet, the system costs no more than any other Taurus engine.

ENVIRONMENT

PERFORMANCE

The potent 3.0-liter 24-valve Duratec V6 puts 200 horsepower at your beck and call. Optional.

The 3.0-liter Duratec V6 and the 3.0-liter Vulcan V6 are designed to go 100,000 miles without a scheduled tune-up.*

*Under normal driving conditions with routine fluid and filter changes.

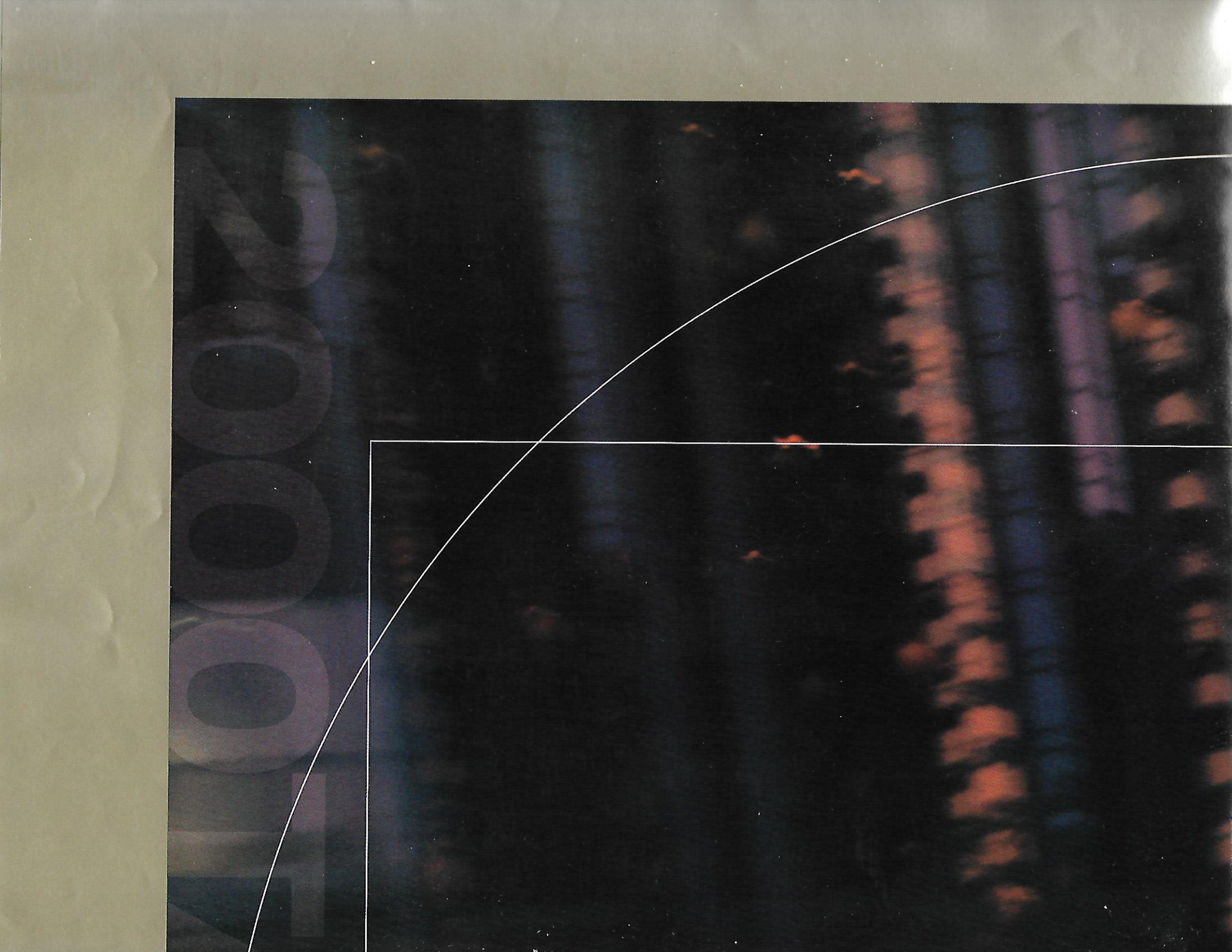



62.1"

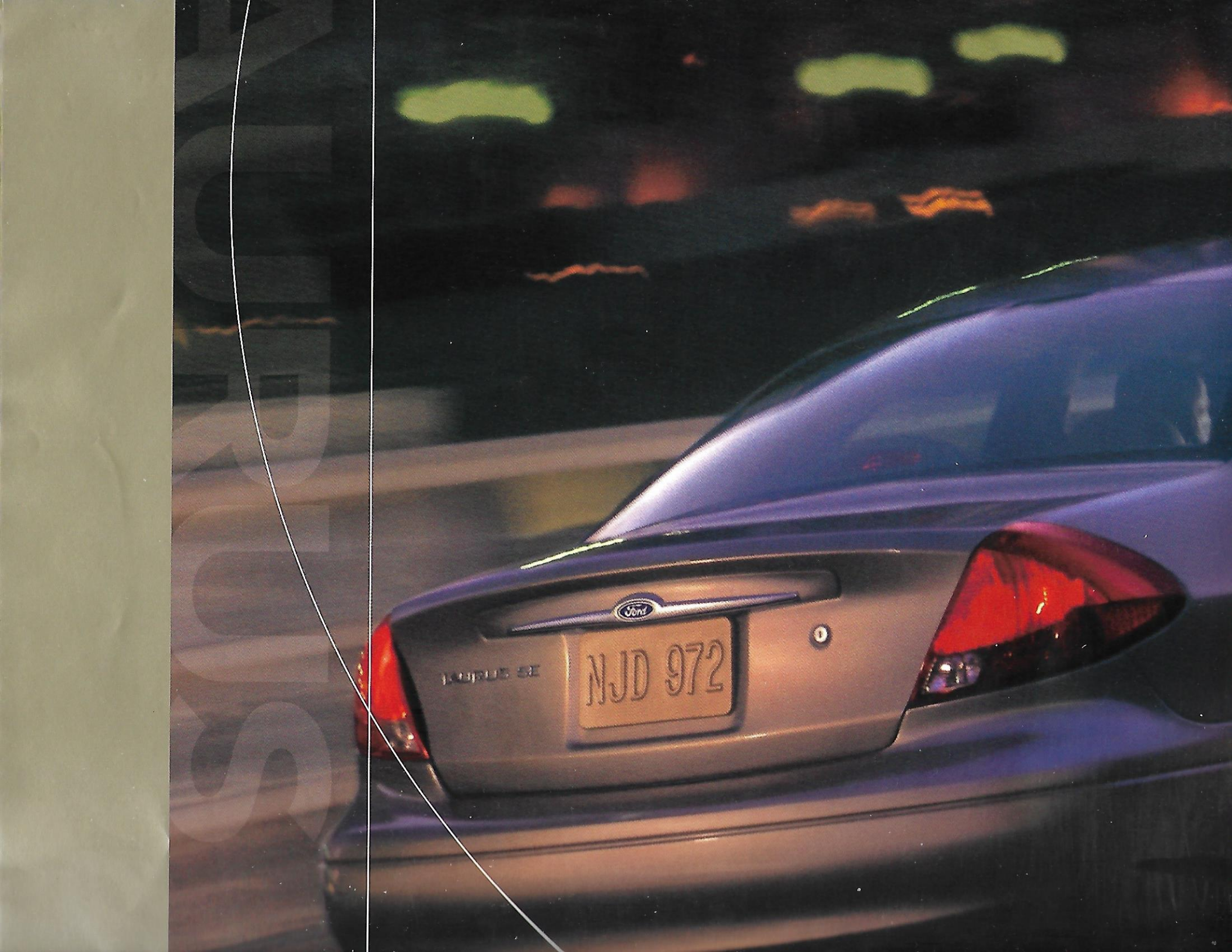

TAURUS SE



NJD 972



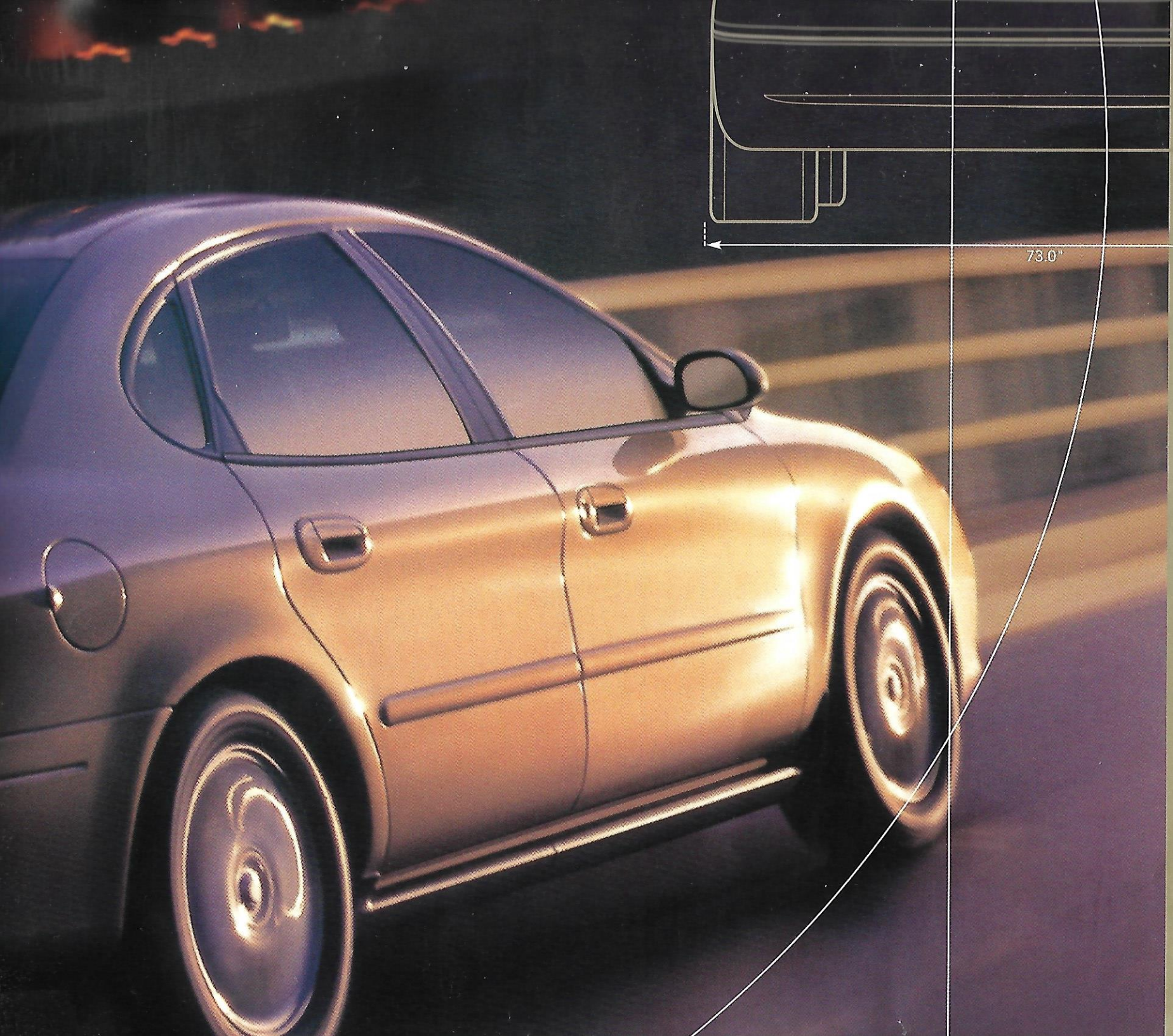

73.0"

Taurus LX Sedan comes nicely appointed. W

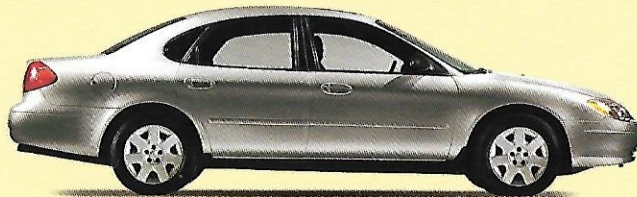

Exterior:

- 5-mph bumpers
- Black power mirrors
- Bodyside moldings
- 6-spoke bolt-on wheel covers

Interior:

- Personal Safety System
- Dual-stage airbags
- Electronic digital clock
- Cupholders/cassette stowage
- Grocery bag hooks
- Integrated control panel
- Light Group
- AM/FM stereo with four speakers
- Five-passenger seating (six-passenger optional)
- Child safety seat tether anchors for rear seating positions
- Tilt steering column

Functional:

- Air conditioning, manual
- Air extractors
- Battery saver
- Power brakes
- Belt-Minder Warning System
- Rear window defroster



Exterior:

- 5-mph bumpers
- Body-color power mirrors
- Bodyside moldings
- 5-spoke painted aluminum wheels*

Interior:

- Personal Safety System
- Dual-stage airbags
- Electronic digital clock
- Cupholders/cassette stowage
- Grocery bag hooks
- Integrated control panel
- Light Group
- AM/FM stereo cassette with four speakers
- Five-passenger seating (six-passenger optional)
- Child safety seat tether anchors for rear seating positions
- Tilt steering column

Functional:

- Air conditioning, manual
- Air extractors
- Battery saver
- Power brakes
- Belt-Minder Warning System
- Rear window defroster

Walk through the series and it gets even better.



Exterior:
5-mph bumpers
Body-color power mirrors
Bodyside moldings
5-spoke painted aluminum wheels

Interior:
Personal Safety System
Dual-stage airbags
Electronic digital clock
Cupholders/cassette stowage
Grocery bag hooks
Integrated control panel
Light Group
AM/FM stereo cassette with four speakers
Six-passenger seating with 3-way flip/fold console
(five-passenger optional)
Child safety seat tether anchors for rear seating positions
Tilt steering column
Illuminated visor mirrors with secondary visors
60/40 split/fold rear seat

Functional:
Air conditioning, manual
Air extractors
Battery saver



Exterior:
5-mph bumpers
Body-color power heated mirrors
Bodyside moldings
5-spoke machined aluminum wheels
Autolamps with delay

Interior:
Personal Safety System
Dual-stage airbags
Electronic digital clock
Cupholders/cassette stowage
Grocery bag hooks
Integrated control panel
Light Group
AM/FM stereo cassette with four speakers
Six-passenger seating with 3-way flip/fold console
(five-passenger optional)
Child safety seat tether anchors for rear seating positions
Tilt steering column
Illuminated visor mirrors with secondary visors
60/40 split/fold rear seat
Leather-wrapped steering wheel

Functional:
Air conditioning, automatic



Medium Parchment
Cloth shown

Child safety rear door locks
Particulate Air Filtration System
SecuriLock™ Passive Anti-Theft System
P215/60R16 94T all-season tires
Rear stabilizer bar
Intermittent windshield wipers
Power windows

Child safety rear door locks
Particulate Air Filtration System
SecuriLock™ Passive Anti-Theft System
P215/60R16 94T all-season tires
Rear stabilizer bar
Intermittent windshield wipers
Power windows
Remote Keyless Entry System
Speed control
Power locks

*6-way power driver's seat may be substituted for no additional charge.

16" x 6" bolt-on steel wheels.
Standard on LX, optional on SE Sedan.



16" x 6" 5-spoke painted
aluminum wheels. Standard on SE Sedan,
SE Wagon and SES.



16" x 6" 5-spoke machined aluminum
wheels. Standard on SEL.



Optional equipment:

Anti-lock brakes
Adjustable pedals
All-Speed Traction Control
Leather seating surfaces
MACH® Audio System with 6-disc changer
Power passenger seat
Power moonroof
Side impact airbags
60/40 split/fold seat
Flex fuel 3.0-liter Vulcan V6
3.0-liter 24-valve Duratec V6
Floor mats

Optional Wagon equipment:

Wagon Group:
3rd-row rear-facing seat
Cargo cover

SES Wagon Group:
4-wheel ABS
6-way power driver's seat
Illuminated visor mirrors
with secondary visors

Product Changes and Options Availability

Following publication of the catalog, certain changes in standard equipment, options, prices and the like, or product delays, may have occurred which would not be included in these pages. Your Ford Dealer is your best source for up-to-date information. Ford Division reserves the right to change product specifications at any time without incurring obligations. Options shown or described are available at extra cost and may be offered only in combination with other options or subject to additional ordering requirements or limitations.

Battery saver
Rear window defroster
Emergency inside trunk release
3.0-liter Vulcan V6
Child safety rear door locks
Particulate Air Filtration System
SecuriLock™ Passive Anti-Theft System
P215/60R16 94T all-season tires
Rear stabilizer bar
Intermittent windshield wipers
Power windows
Remote Keyless Entry System
Speed control
Power locks
4-wheel ABS
6-way power driver's seat

Battery saver
Power brakes
Belt-Minder Warning System
Rear window defroster
Emergency inside trunk release
3.0-liter 24-valve Duratec V6
Child safety rear door locks
Particulate Air Filtration System
SecuriLock™ Passive Anti-Theft System
P215/60R16 94T all-season tires
Rear stabilizer bar
Intermittent windshield wipers
Power windows
Remote Keyless Entry System (with keypad)
Speed control
Power locks
4-wheel ABS
Six-way power driver's seat
Electronic temperature control



Medium Graphite
Cloth shown



Dark Charcoal
Leather Trim shown

SE Wagon includes the following equipment:

Exterior:

Flip-up backlight glass with gas cylinders
5-mph bumpers with step pads
Aerodynamic luggage rack with
adjustable crossbar and tie-downs

Interior:

Cargo courtesy light

Functional:

Power antenna
Four-wheel disc brakes
Tie-downs

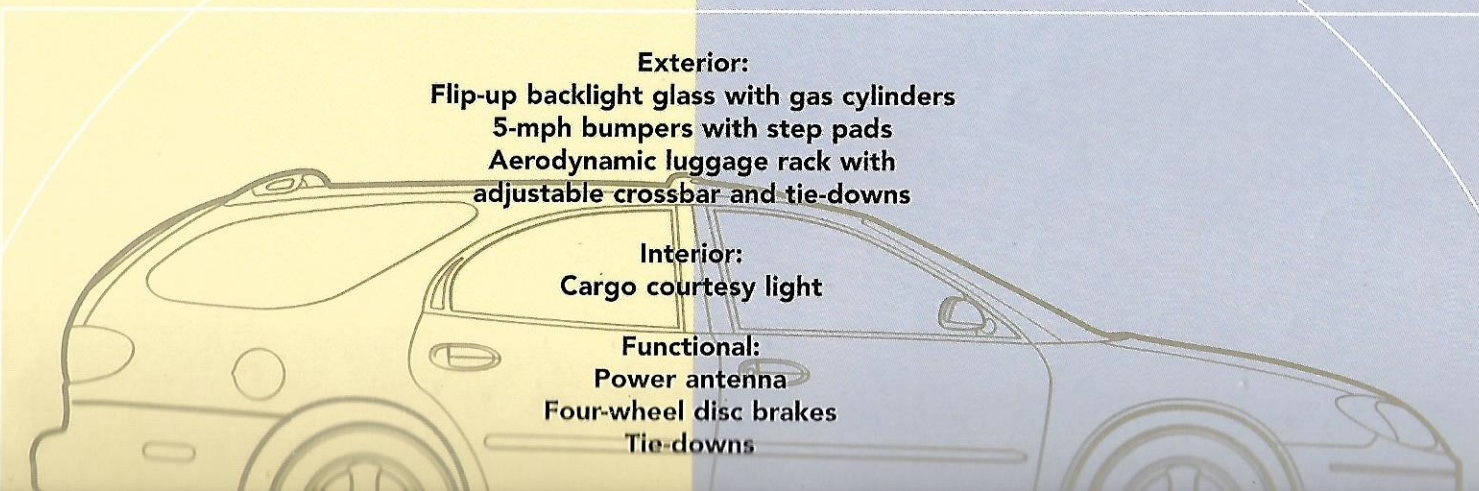



Tropic Green
Clearcoat Metallic



Toreador Red
Clearcoat Metallic



Graphite Blue
Clearcoat Metallic



Chestnut Brown
Clearcoat Metallic



Black
Clearcoat



Harvest Gold
Clearcoat Metallic



Silver Frost
Clearcoat Metallic



Medium Royal Blue
Clearcoat Metallic

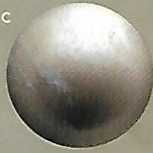

Performance White

We Race. You Win.™
It's how Ford describes technology transfer. In many ways, the NASCAR Taurus is a prototype. Innovations that have made it a point leader in the Winston Cup Series are likely to make it into production. Into your Taurus. With perhaps a little less fanfare.

Accessories



Rear Spoiler comes with integrated rear brake light.



Splash Guards protect lower body panels from stones and other road debris.

Roadside Assistance

Every new Ford includes the assurance of a 24-hour emergency Roadside Assistance Program provided during the 3-year/36,000-mile limited warranty period. Ask your Ford Dealer for complete details on this program which includes such services as fuel delivery, tire change, jump start, or even help when you're locked out of your vehicle.

New Vehicle Limited Warranty

Under the New Vehicle Limited Warranty, you receive bumper-to-bumper coverage for 3 years/36,000 miles with no deductible. You also receive corrosion/performance coverage for five years with unlimited mileage and no deductible. Ask your Ford Dealer for a copy of the warranty.

Competitive comparisons based on published 1999 competitive data.

fordforce
COMMUNITY ACTION TEAM

Visit our website at
www.fordvehicles.com

