

WHERE POWER MEETS PRECISION

# 2013 GMC SIERRA

WE ARE PROFESSIONAL GRADE.

**GMC**



# 2013 GMC SIERRA

GMC. Our commitment is to push the limits of what's possible. Our dedication is to build professional-grade SUVs, trucks and vans. Our products are purposefully engineered to offer you the highest standards of performance, innovation and versatility. Like you, GMC believes that just being good enough is never enough and jobs worth doing are worth doing well. It's why the 2013 Sierra was built to work smart as well as efficiently. It's why Sierra can offer over 300 horsepower and an EPA-estimated 22 hwy mpg<sup>1</sup> in the same V-8 engine.

GMC. We are Professional Grade.

## MODELS

---

SIERRA DENALI & DENALI HD	pg. 2
SIERRA 1500	pg. 6
SIERRA ALL-TERRAIN	pg. 10
SIERRA 2500HD	pg. 12
SIERRA 3500HD	pg. 14
FEATURES & BENEFITS	pg. 16
COLOR & TRIM	pg. 30
ACCESSORIES	pg. 32
EQUIPMENT OPTIONS	pg. 34

<sup>1</sup>Sierra XFE model.





SIERRA 1500 CREW CAB SLT IN QUICKSILVER METALLIC shown with available equipment.



**SIERRA 1500 DENALI** (upper)

Our ½-ton Sierra 1500 Denali has a long list of standard features, including our 6.2L V-8. So you'll be able to combine strength and capability with premium features to create a truck tailored to your purpose.

**SIERRA 2500 DENALI HD** (center)

Our ¾-ton Sierra 2500HD Denali sits on a fully boxed, high-strength steel frame specifically engineered for HD applications. With the available Duramax Diesel 6.6L V-8 Turbo, it has a trailering capacity of up to 16,500 lbs.<sup>1</sup>

**SIERRA 3500 DENALI HD** (lower)

Our 1-ton Sierra 3500HD Denali is the ultimate expression of professional-grade engineering. It offers an available maximum payload of up to 5355 lbs<sup>2</sup> and maximum trailering of up to 22,600 lbs<sup>1</sup> with the available Duramax Diesel 6.6L V-8 Turbo.



**SIERRA DENALI & DENALI HD  
ELEVATING THE STANDARD  
OF EXCELLENCE.**

Professional Grade—at GMC, that's how we build our Sierra pickup truck, and Sierra Denali raises that standard to the highest levels of excellence. Available in all Sierra series, from 1500 and 2500HD to our 3500HD with single or dual rear wheels—no GMC truck works harder, works smarter, than Sierra Denali. It's smarter, thanks to Sierra 1500 Denali's standard Vortec 6.2L V-8. No competitor's V-8-powered pickup offers you 400-plus horsepower with better fuel economy.<sup>3</sup> It's stronger, thanks to Sierra Denali HD's available Duramax Diesel 6.6L V-8—the most powerful engine ever offered in a GMC HD pickup truck. A combination of iconic grille, wheels and chrome accents distinguish the Denali exterior, while inside, Sierra Denali models reward you with a spacious interior so refined, it rivals the comfort and technology of the finest passenger sedans.

**SIERRA 1500 DENALI FEATURES**

For details, see corresponding page number listed below.

6.2L V-8 VVT Engine	pg. 17	Eaton® Automatic Locking Rear Differential	pg. 19
403 Horsepower	pg. 17	StabiliTrak Stability Control System	pg. 20
417 lb-ft Torque	pg. 17	20" Chrome Aluminum Wheels	pg. 29

<sup>1</sup>Maximum trailer weight ratings are calculated assuming a base vehicle, except for any option(s) necessary to achieve the rating, plus driver. The weight of other optional equipment, passengers and cargo will reduce the maximum trailer weight your vehicle can tow. See your GMC dealer for additional details. <sup>2</sup>Maximum payload capacity includes weight of driver, passengers, optional equipment and cargo. <sup>3</sup>EPA estimated mpg Sierra Denali with 6.2L V-8: 13 city/19 hwy. Based on GM 2012 Large Pickup segment.



SIERRA 1500 DENALI IN ONYX BLACK shown with available equipment.



SIERRA 2500 DENALI HD INTERIOR IN EBDONY shown with available equipment.



## SIERRA DENALI INTERIOR ITS DETAILS HAVE DETAILS.

Sierra Denali is a truck built by—and for—those who demand attention to detail. Its seating surfaces are trimmed in a premium leather material that's perforated for comfort. Its front seats are not only heated—they're cooled, too, and feature 12-way power adjustment. The gauge cluster integrates a Driver Information Center that puts valuable information in one place. Every surface your eye scans tells you this is no ordinary truck. Every feature you engage fulfills Denali's aim to be the ultimate Sierra.

### SIERRA DENALI INTERIOR FEATURES

For details, see corresponding page number listed below.

12-Way Power Heated & Cooled Front Seats pg. 24

Automatic Dual-Zone Climate Control pg. 24

Leather-Wrapped Heated Steering Wheel pg. 24

Bose® Centerpoint® Surround Sound System pg. 26



SIERRA 1500 CREW CAB SLT IN QUICKSILVER METALLIC shown with available equipment.





## SIERRA 1500 WASTE NOT, WANT NOT.

For Sierra 1500, GMC engineers have achieved a remarkable balance of power with fuel efficiency. It starts with Sierra XFE, our 2WD V-8-powered Crew Cab. Its standard 315-hp 5.3L V-8 offers an EPA-estimated 22 hwy mpg, the best of any competitive V-8 in its class.<sup>1</sup> Sierra 1500 is also available with a 403-hp Vortec 6.2L V-8 that is the highest output V-8 we've ever put in a GMC 1/2-ton pickup.

### AVAILABLE SIERRA 1500 FEATURES

For details, see corresponding page number listed below.

5.3L V-8 Engine	pg. 16	6-Speed Automatic Transmission	pg. 18
Active Fuel Management	pg. 16	StabiliTrak, Standard	pg. 20
315 Horsepower	pg. 17	20" Chrome Wheels	pg. 29

<sup>1</sup>EPA-estimated mpg Sierra XFE with 5.3L V-8 15 city/22 hwy. Based on GM 2012 Large Pickup segment.



### 1500 EXTENDED CAB

The rear doors of Sierra 1500 Extended Cab open 170 degrees, creating an ease of access for passengers and cargo that makes this Sierra ideal for everyday use.



**STEERING WHEEL CONTROLS** (upper)

Available steering-wheel-mounted controls allow the Sierra 1500 driver convenient access to radio volume and Bluetooth<sup>1</sup> for phone while keeping all eyes on the road.

**REAR-VISION CAMERA SYSTEM** (lower)

To help make backing out of parking spaces or hitching up trailers easier, a rear-vision camera displays what's in its field of vision. The available system places a monitor in your rearview mirror or navigation screen, if equipped.



**SIERRA SLT INTERIOR  
PURPOSE, DRIVEN.**

Sierra 1500 SLT wraps proven capability around an interior that combines comfort, convenience and style. The leather-appointed, 10-way adjustable front seats welcome you into a world where everything serves a purpose. Sierra's ergonomic design puts important functions easily within the driver's reach, including steering-wheel-mounted audio and cruise controls and an available touch-screen Navigation System.<sup>2</sup>

**AVAILABLE SIERRA 1500 INTERIOR FEATURES**

For details, see corresponding page number listed below.

Automatic Dual-Zone Climate Control	pg. 24	Rear-Vision Camera System	pg. 25
10-Way Power Front Seats	pg. 24	Touch-Screen Navigation <sup>2</sup>	pg. 26

<sup>1</sup>Go to [gm.com/bluetooth](http://gm.com/bluetooth) to find out which Bluetooth phones are compatible with the vehicle. <sup>2</sup>Map coverage for Puerto Rico and the U.S. Virgin Islands available on separate disc. Coverage not available for portions of Canada.



SIERRA 1500 SLT INTERIOR IN LIGHT TITANIUM shown with available equipment.

## SIERRA ALL-TERRAIN AN OFF-ROAD ALL-STAR.

When the pavement ends, Sierra All-Terrain is well-prepared. It was born ready, thanks to a Z71 Off-Road Suspension with off-road jounce bumpers, a high-capacity air cleaner and skid plates designed to protect the front underbody, oil pan, differential and transfer case (if equipped). Rancho® Tenneco™ shocks enhance its ability to take on challenging terrain. You decide the source of power: the standard 315-hp 5.3L V-8 or available 403-hp 6.2L V-8. You decide the style preferred: a four-bar chrome grille, chrome-accented bodyside molding and 18-inch chrome wheels, or body-color trim with body-color grille, bumpers, mirrors and door handles with 20-inch chrome wheels. Whichever you choose, Sierra All-Terrain is off-road ready the second you drive it off the showroom floor.

### SIERRA ALL-TERRAIN FEATURES

For details, see corresponding page number listed below.

Available 403-hp 6.2L V-8	pg. 17	Heavy-Duty Trailing Package	pg. 34
Eaton Automatic Locking Rear Differential	pg. 19	Rancho Tenneco Shocks	pg. 34
18" Chrome-Clad Aluminum Wheels	pg. 29	Z71 Off-Road Suspension	pg. 34





SIERRA BODY COLOR ALL-TERRAIN IN SUMMIT WHITE shown with available equipment.



#### SIERRA ALL-TERRAIN INTERIOR

The brushed aluminum trim and available two-tone leather-appointed seating give Sierra All-Terrain an interior designed to match its unique exterior style.

## SIERRA 2500HD STRENGTH WITH INTELLIGENCE.

Sierra 2500HD leads its class with a maximum <sup>3</sup>/<sub>4</sub>-ton fifth-wheel trailer rating of up to 17,800 lbs.<sup>1</sup> It is strength combined with smarts, thanks to two innovations. StabiliTrak is a stability control system that helps you stay on the path you are steering in bad weather or on uneven road surfaces. Trailer Sway Control uses StabiliTrak's sensors to detect the rocking of a swaying trailer, then automatically applies the vehicle's brakes to bring it back in line. Need range? Sierra 2500HD with the available Duramax Diesel 6.6L V-8 Turbo has a highway mileage range of up to 680 miles.<sup>2</sup>

### SIERRA 2500HD FEATURES

For details, see corresponding page number listed below.

6.0L V-8, 360 hp, 380 lb-ft Torque	pg. 17	36-Gallon Fuel Tank (approx.)	pg. 21
Fully Boxed Steel Frame	pg. 20	13,000 lb Conventional Hitch Max Trailer Rating <sup>1</sup>	pg. 40
Available Diesel Exhaust Brake	pg. 21	17,800 lb Fifth-Wheel Max Trailer Rating <sup>1</sup>	pg. 40

<sup>1</sup>Maximum trailer weight ratings are calculated assuming a base vehicle, except for any option(s) necessary to achieve the rating, plus driver. The weight of other optional equipment, passengers and cargo will reduce the maximum trailer weight your vehicle can tow. See your GMC dealer for additional details. <sup>2</sup>Based on GM testing and fuel tank capacity. Your range may be less. <sup>3</sup>Maximum payload capacity includes weight of driver, passengers, optional equipment and cargo.

SIERRA 2500HD CREW CAB SLT IN QUICKSILVER METALLIC shown with available equipment.



**PAYLOAD AND TRAILERING** (below, top left)

Sierra 2500HD has a maximum payload of up to 4212 lbs.<sup>3</sup> and with the available Duramax Diesel 6.6L V-8 Turbo, a maximum trailering capacity of up to 13,000 lbs<sup>1</sup> with a conventional ball hitch, or up to 17,800 lbs<sup>1</sup> with a fifth-wheel or gooseneck hitch.

**FOLDING MIRRORS** (below, top right)

The outside mirrors fold to make it easier to navigate tight spaces, or available camper mirrors (shown at bottom) extend to give you a wide view and you can retract them when parking in narrow spaces.

**RECIRCULATING BALL STEERING** (bottom)

Who says the steering in a heavy-duty pickup needs to feel sluggish? Sierra HD models feature recirculating ball steering, which helps give the driver direct feedback to steering inputs. So the response is quick and nimble.





#### PAYLOAD CAPACITY (upper)

The most capacity you can get in a GMC Sierra? Our 3500HD Regular Cab 2WD Long Bed with dual rear wheels with a best-in-class payload capacity of up to 7222 lbs.<sup>1</sup> If it's cargo and crew you need to haul, or a combination of both, the Sierra Crew is a Sierra built for the heaviest of heavy-duty jobs.

#### WIDE-VIEW MIRROR (center)

All 3500HD models come standard with vertical camper-style, convex spotter surface mirrors that help you see what's along your flanks when you're trailering a wide load.

#### TRAILERING CAPACITY (lower)

With a best-in-class 1-ton maximum fifth-wheel trailering capacity of up to 23,100 lbs<sup>2</sup> and a GCWR of 30,500 lbs,<sup>3</sup> Sierra 3500HD puts professional-grade power to work for you (Crew Cab model shown can trailer up to 22,500 lbs<sup>3</sup>).



## SIERRA 3500HD EXCUSELESS.

The 2013 Sierra 3500HD is simply the toughest, strongest, most capable 1-ton pickup truck we've ever built. Its available Duramax Diesel 6.6L V-8 Turbo generates 765 lb-ft of torque and 397 horsepower that will keep the momentum rolling effortlessly all day long, thanks to an Allison<sup>®</sup> 6-speed transmission geared to put you in precisely the right rpm range for optimum performance and efficiency. Sierra 3500HD's powertrain is mounted to a fully boxed frame that's 92 percent stronger and has five times more torsional stiffness than our previous generation heavy-duty frame.

#### SIERRA 3500HD FEATURES

For details, see corresponding page number listed below.

6.0L V-8, 360 hp, 380 lb-ft Torque	pg. 17	36-Gallon Fuel Tank (approx.)	pg. 21
Fully Boxed Steel Frame	pg. 20	18,000-lb Conventional Hitch Max Trailer Rating <sup>2</sup>	pg. 40
Available Diesel Exhaust Brake	pg. 21	23,100-lb Fifth-Wheel Max Trailer Rating <sup>2</sup>	pg. 40

<sup>1</sup>Maximum payload capacity includes weight of driver, passengers, optional equipment and cargo. <sup>2</sup>Maximum trailer weight ratings are calculated assuming a base vehicle, except for any option(s) necessary to achieve the rating, plus driver. The weight of other optional equipment, passengers and cargo will reduce the maximum trailer weight your vehicle can tow. See your GMC dealer for additional details. <sup>3</sup>When properly equipped, includes weight of the vehicle and trailer combination, including the weight of driver, passengers, fuel, optional equipment and cargo in the vehicle and trailer.





SIERRA 3500HD CREW CAB SLT WITH DUAL REAR WHEELS IN QUICKSILVER METALLIC shown with available equipment.

# 1500 ENGINES

Vortec gasoline-powered V-6 and V-8 engines available in Sierra 1500 are remarkable for the technology they bring to the full-size pickup. The results: power of up to 403 hp from the available Vortec 6.2L V-8, and competition-leading V-8 fuel efficiency of up to 22 mpg hwy from the available Vortec 5.3L V-8<sup>1</sup>

<sup>1</sup>EPA-estimated 22 mpg hwy for Sierra XFE. Based on 2012 GM Large Pickup segment.

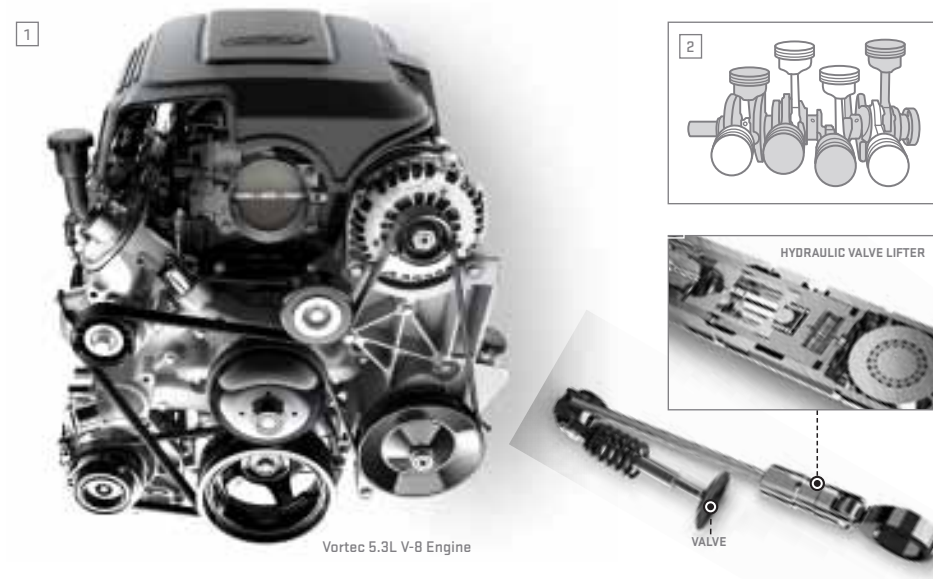

**1 VORTEC ENGINES** To give you uncompromised power and torque for confident daily driving, passing and trailering, look no further than the Vortec engine family. Each model uses innovative “vortex technology” to swirl and tumble incoming air and fuel for optimum power and response.

**VARIABLE VALVE TIMING (VVT)** For easy responsiveness in low-speed city driving and bold power for open-road passing or trailering, many Vortec engines feature VVT. It monitors and changes valve open and close points for near-peak levels of torque across the entire range of engine speeds.

**2 ACTIVE FUEL MANAGEMENT** Sierra 5.3L V-8 engines use Active Fuel Management. This available system senses load and demand, then activates or deactivates four of the engine’s eight cylinders. In Sierra XFE, the result is competition-leading V-8 EPA-estimated highway fuel economy of 22 mpg.<sup>2</sup> A valve lifter [above] deactivates the cylinder. Under high-demand conditions, the valve’s switching mechanism is depressurized, reengaging the cylinder and restoring full power, without you ever noticing the transition.

<sup>2</sup>Based on GM 2012 Large Pickup segment.

# HD ENGINES

Sierra 2500HD and 3500HD models offer Vortec V-8 gasoline and Duramax Diesel engines. No matter which you choose, you’ll have plenty of what you demand from a heavy-duty pickup: power and torque, with deep reserves of both for when your right foot asks for maximum effort.



**3 DURAMAX DIESEL 6.6L V-8 TURBO** With direct-injection technology that helps it start in as little as 3.0 seconds at -40°F and a sophisticated Allison<sup>®</sup> transmission with overdrive, the available Duramax Diesel 6.6L gives you a maximum highway range of up to 680 miles on a single fill-up.<sup>3</sup>

<sup>3</sup>Based on GM testing and fuel tank capacity. Your range may be less.

**DURAMAX B20 BIODIESEL CAPABILITY** To reduce carbon-dioxide emissions and stretch your fuel budget, the Duramax 6.6L can operate on B20 biodiesel, a mix of 20 percent biodiesel from domestic, renewable resources, and 80 percent petroleum diesel.

**DURAMAX HIGH-PRESSURE DIRECT INJECTION** For fast starts in cold weather, quieter operation and maximum efficiency, the direct injection system operates at nearly 30,000 psi to turn heavy diesel fuel into a fine mist, burning cleaner and faster with lower emissions and greater power than the previous model.

# HYBRID

GMC engineers gave Sierra Hybrid the capability of a V-8 with the efficiency of a four-cylinder. The result: 332 horsepower, 367 lb-ft torque, up to 1527 lbs of payload<sup>4</sup> and up to 6100 lbs of conventional trailering<sup>5</sup>—all with a category-leading fuel economy of an EPA-estimated 20 city/23 hwy.<sup>6</sup>

<sup>4</sup>Maximum payload capacity includes weight of driver, passengers, optional equipment and cargo. <sup>5</sup>Maximum trailer weight ratings are calculated assuming a base vehicle, except for any option(s) necessary to achieve the rating, plus driver. The weight of other optional equipment, passengers and cargo will reduce the maximum trailer weight your vehicle can tow. See your GMC dealer for additional details. <sup>6</sup>Based on GM 2012 Large Pickup segment.

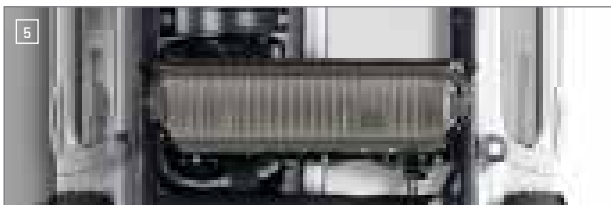

**4 HYBRID MODEL VORTEC 6.0L V-8 VVT (LZ1) WITH ACTIVE FUEL MANAGEMENT** To deliver outstanding economy<sup>7</sup> without compromise to torque or horsepower, the 6.0L V-8 VVT is engineered with Active Fuel Management technology to deactivate four of its eight cylinders under light loads and low speeds. At highway speeds, the cylinders reactivate in an instant to give you full engine power.

<sup>7</sup>EPA-estimated mpg 20 city/23 hwy.

**5 300-VOLT NiMH BATTERY PACK** The Nickel-Metal Hydride (NiMH) battery technology can store a lot of energy in a small space. In fact, the 300-volt battery pack is strong enough to propel your Sierra for miles, yet small enough to fit under the rear seat.

**HYBRID MODEL 2-MODE ELECTRONICALLY VARIABLE TRANSMISSION** To conserve fuel at low speeds or under light loads, this 2-mode transmission has two integral electronic motors that engage to give Sierra Hybrid smooth, effortless power. At higher loads and speeds with the 6.0L V-8 fully engaged, it acts as a normal automatic transmission.

**REGENERATIVE BRAKING SYSTEM** During normal stops, regenerative braking uses the motors in the hybrid transmission as generators to slow the vehicle by applying resistance in the motors rather than brake friction. Simultaneously, that energy is captured as electricity in the 300-volt battery pack, available for the next acceleration cycle.

# ALL ENGINES

At GMC, we've always believed in building the right tool for the job. With Sierra, that translates into the widest range of engines of any pickup truck manufacturer. We also believe that keeping your GMC operating at peak performance should be easy, and thanks to innovative features like an Oil Life Monitor and available OnStar engine diagnostics, it is.

## 1500 ENGINES

<b>VORTEC 4.3L V-6 [LU3]</b>	<b>HORSEPOWER:</b> 195 hp @ 4600 rpm	<b>TORQUE:</b> 260 lb-ft @ 2800 rpm
<b>VORTEC 4.8L V-8 VVT [L20]</b> FlexFuel Capable	<b>HORSEPOWER:</b> 302 hp @ 5600 rpm	<b>TORQUE:</b> 305 lb-ft @ 4600 rpm
<b>VORTEC 5.3L V-8 VVT [LMG]</b> Active Fuel Management/FlexFuel Capable, Iron Block	<b>HORSEPOWER:</b> 315 hp @ 5200 rpm	<b>TORQUE:</b> 335 lb-ft @ 4000 rpm
<b>VORTEC 5.3L V-8 VVT [LC9]</b> Active Fuel Management/FlexFuel Capable, Aluminum Block	<b>HORSEPOWER:</b> 315 hp @ 5200 rpm	<b>TORQUE:</b> 335 lb-ft @ 4000 rpm
<b>VORTEC 6.2L V-8 VVT [L9H]</b> FlexFuel Capable	<b>HORSEPOWER:</b> 403 hp @ 5700 rpm	<b>TORQUE:</b> 417 lb-ft @ 4300 rpm

## HEAVY DUTY ENGINES

<b>VORTEC 6.0L V-8 VVT [L96]</b> FlexFuel Capable	<b>HORSEPOWER:</b> 360 hp @ 5400 rpm <sup>7</sup>	<b>TORQUE:</b> 380 lb-ft @ 4200 rpm
<b>DURAMAX DIESEL 6.6L V-8 TURBO</b>	<b>HORSEPOWER:</b> 397 hp @ 3000 rpm	<b>TORQUE:</b> 765 lb-ft @ 1600 rpm

## HYBRID ENGINE

<b>VORTEC 6.0L V-8 VVT [LZ1]</b> Active Fuel Management EPA-est. mpg [city/highway]: 20/23	<b>HORSEPOWER:</b> 332 hp @ 5100 rpm	<b>TORQUE:</b> 367 lb-ft @ 4100 rpm
--	--------------------------------------	-------------------------------------

**OIL LIFE MONITOR** For long life and durability, nothing is more important than changing your oil at the right time. GMC engineered the mystery out of this essential service with the Oil Life Monitor. It calculates how much life your oil has left, based on when and how you drive. Then, it updates you with a telltale on your Driver Information Center.

**E85 FLEXFUEL CAPABILITY<sup>9</sup>** Most Sierra gas V-8 engines are capable of running on E85 ethanol, an advanced biofuel.

<sup>9</sup>E85 is a blend of 85 percent ethanol and 15 percent regular gasoline. Visit [gmc.com](http://gmc.com) and search E85 for more information on E85 as an alternative fuel.

**ONSTAR VEHICLE DIAGNOSTICS<sup>10</sup>** Standard with your 6-month trial subscription to OnStar, the OnStar Vehicle Diagnostics service can run hundreds of checks of your engine, transmission, antilock brakes and more, then organize the information into an easy-to-read monthly report. OnStar can also run a check of your vehicle as you drive just by pressing the blue button and asking the Advisor for an On-Demand Diagnostics check. So now, the peace of mind that comes from knowing the condition of your Sierra's key systems is as easy as checking your e-mail.

<sup>10</sup>Visit [onstar.com](http://onstar.com) for details and system limitations.

**TRACTION CONTROL SYSTEM** To make the most of available traction on many road surfaces, traction control measures and compares the speed of your wheels. If it senses one or more wheels starting to spin, such as on a slippery surface, the system applies individual brakes and manages engine power to slow the wheel down and maintain traction so you can move forward with a better sense of control.

# TRANSMISSIONS/DRIVETRAIN

A pickup truck's transmission and driveline components are critical to translating every rotation of the engine's crankshaft into power at the drive wheels—power to tow and haul, power to pass, power to grip snow-covered asphalt or gravel-strewn backroads. GMC Sierra offers a range of robust yet refined transmissions precisely matched to maximize the power delivery, efficiency and load demands of our eight Sierra engines.

6

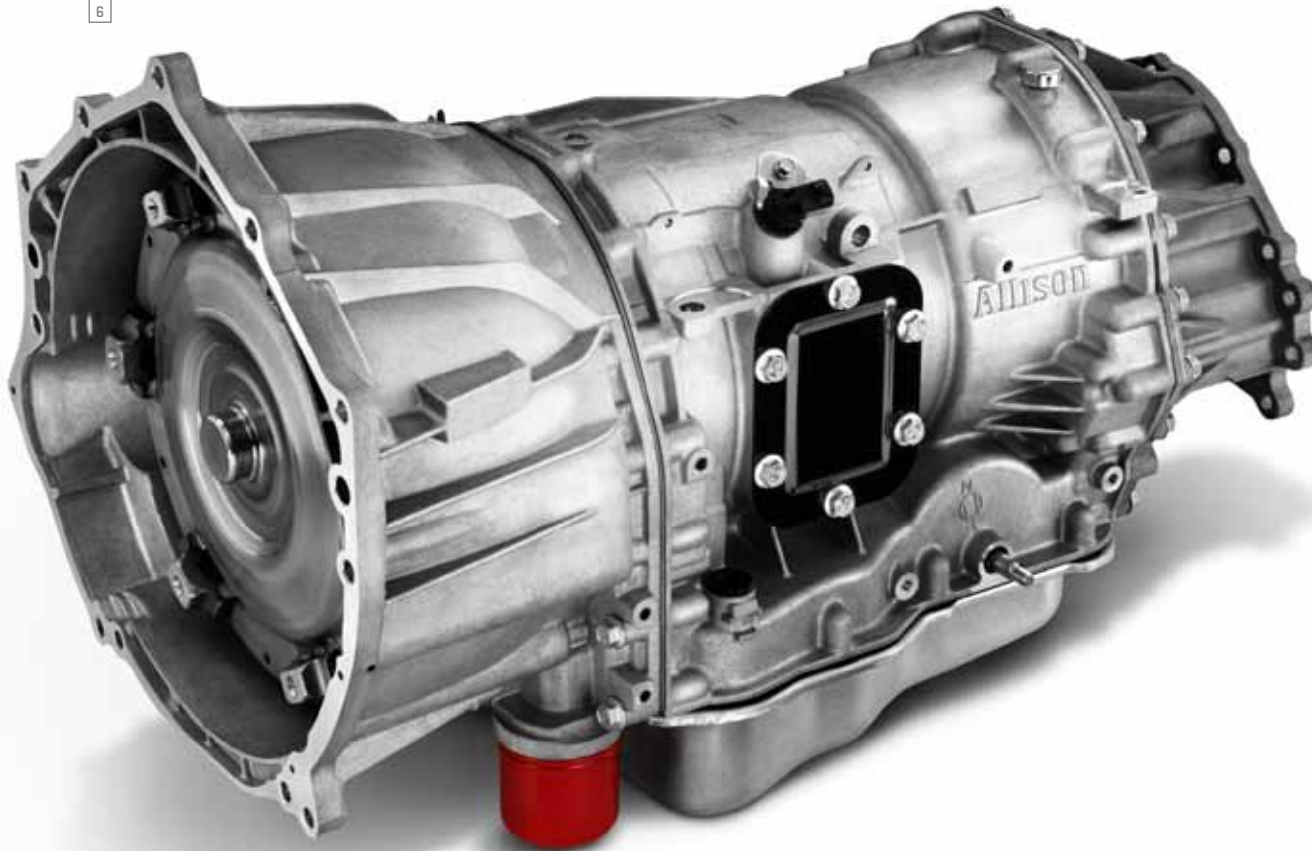

## SIERRA HEAVY DUTY

**6 ALLISON® 1000 SERIES 6-SPEED AUTOMATIC WITH OVERDRIVE** How do you handle the 765 lb-ft of torque produced by Sierra HD's available Duramax Diesel engine? GMC engineers specified the Allison 1000 Series 6-speed automatic with overdrive for its heavy-duty strength and durability.

**HEAVY DUTY 6-SPEED AUTOMATIC WITH OVERDRIVE** Sierra HD's Vortec 6.0L V-8 is mated to a 6-speed automatic with overdrive built for heavy duty. It's a sophisticated tool that features Tow/Haul mode, Driver Shift Control and Automatic Engine Grade Braking to help you use the full potential of Sierra HD with confidence.

## SIERRA 1500

**6-SPEED AUTOMATIC WITH OVERDRIVE** Engineered for control and confidence in a wide variety of situations, the 6L80-E 6-speed automatic is an ideal partner for Sierra 1500's Vortec family of gasoline engines. Filled with innovative technology, this available transmission can help you cut steep climbs, long grades and heavy loads down to size.

**4-SPEED AUTOMATIC OVERDRIVE TRANSMISSION** Proven in millions of Sierra 1500s, this durable 4-speed automatic with overdrive gives you smooth shifts with the strength of millions of miles of experience. It's engineered with Tow/Haul mode to handle maximum loads with ease.

## ALL MODELS

**TOW/HAUL MODE** To give you more power to accelerate, Tow/Haul mode raises transmission up-shift points. This feature also helps you slow your Sierra by raising downshift points, which uses engine compression to slow your Sierra.

**AUTOMATIC ENGINE GRADE BRAKING** Standard with gas-engine 6-speed automatic transmissions, Grade Braking automatically senses when you

want to slow your Sierra, and when the conditions are met, engages a Grade Braking shift schedule that helps you maintain your desired speed.

**DRIVER SHIFT CONTROL** Move through the gears like a manual, with the convenience of an automatic. Move the shift lever to "M," and you get fingertip "tap up/down" range control of transmission gear selection. Included with select automatic transmissions.

**AUXILIARY EXTERNAL TRANSMISSION OIL COOLER**

Available on Sierra 1500 and standard on Sierra HD, an air-to-oil auxiliary cooling unit helps keep transmission temperatures in check—especially critical when trailering or plowing snow.

**ALLISON 1000 SERIES 6-SPEED AUTOMATIC WITH OVERDRIVE**

Designed by the same company that makes transmissions for military tanks, this transmission is the exclusive partner for the available Duramax Diesel engine in Sierra HD.

**AUTOMATIC ENGINE GRADE**

**BRAKING** On all gas-engine Sierra models, the 6-speed transmissions come with Automatic Engine Grade Braking. This feature adds brake assistance on downhill grades, automatically sensing when to slow your Sierra. When the conditions are met, it engages a Grade Braking shift schedule that selects the right gear to optimize engine braking.

**EATON® HEAVY-DUTY AUTOMATIC LOCKING REAR DIFFERENTIAL**

No other competitor in its class offers an available fully automatic locking rear differential for on- and off-road use. Available on Sierra 1500 and Sierra 2500HD and standard on 3500HD, the Eaton Locker senses when there's a difference in rotational speed between left and right rear wheels of approximately 100 rpm. It then locks the differential to turn both rear wheels in unison for added traction.

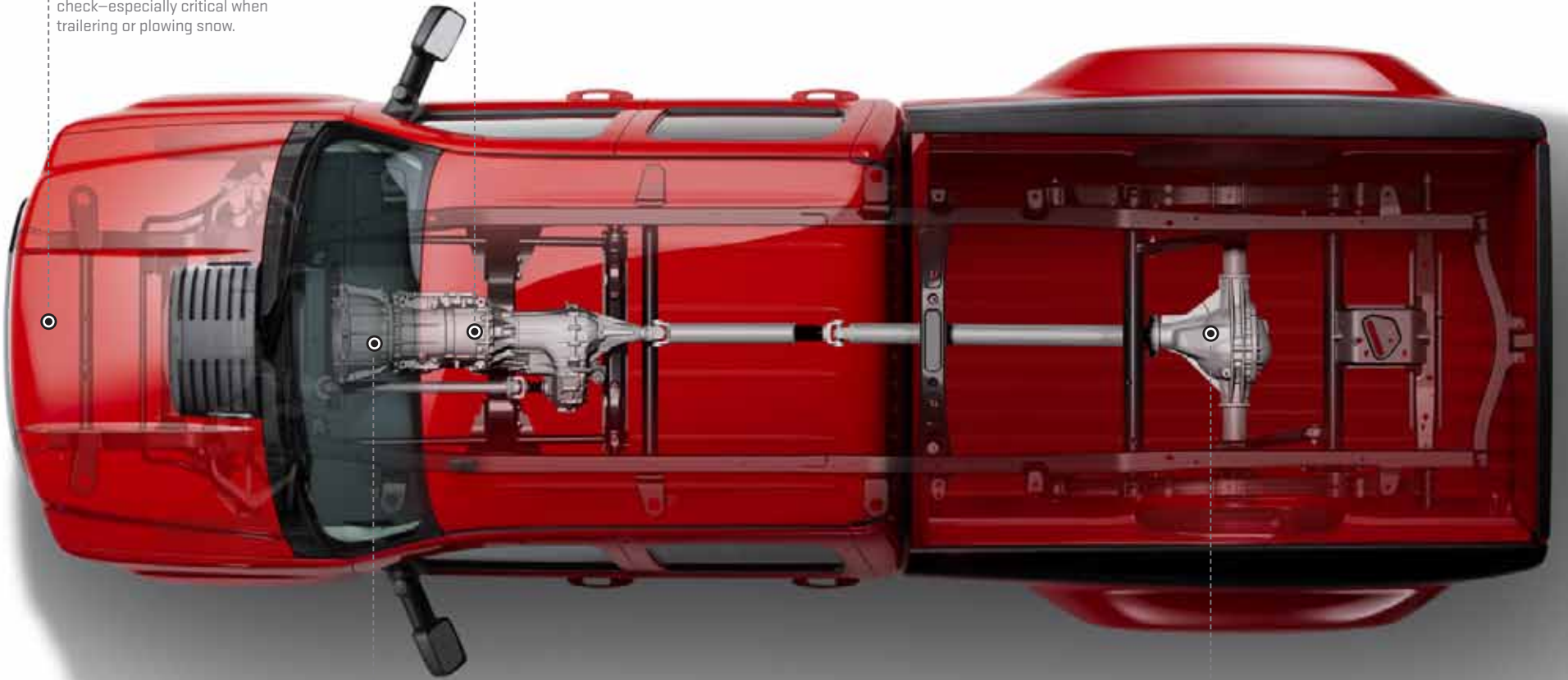

# CHASSIS / CONTROL SYSTEMS

There's a critical difference between just driving a truck and commanding a GMC Sierra. One fundamental source of that difference: the Sierra chassis and control systems. GMC engineers took the powerful drivetrains of Sierra and mounted them to strong, rigid frames—one for Sierra 1500 and another built for Sierra HD models. Then they gave each chassis advanced control systems designed to make driving Sierra and Sierra HD easier under heavy load. One example: StabiliTrak, a stability control system standard on all Single Rear Wheel (SRW) Sierra models. Sensing when your vehicle is not responding to your steering inputs, StabiliTrak adjusts engine speed and applies brake pressure to any individual wheel to help maintain directional control.

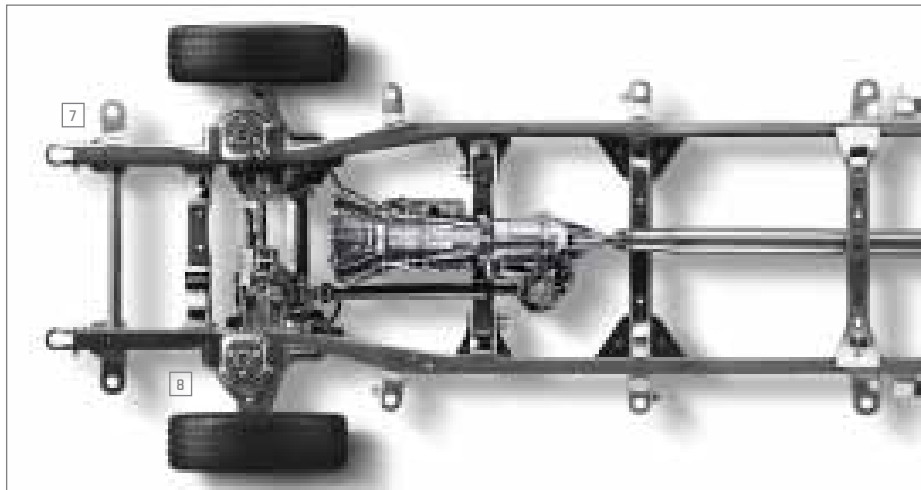

## SIERRA 1500

**7 SIERRA 1500 FRAME** To help resist bending, twisting and shaking, Sierra 1500 frames feature a hydroformed front section and are fully boxed from the nose to the spare tire area. This construction technique essentially welds a frame inside a frame to create a closed “box” section that gives a strong, stable platform for the engine and cab.

**8 FULLY INDEPENDENT FRONT SUSPENSION** On Sierra 1500 models, our coil-over-shock front suspension delivers improved ride quality versus torsion-bar designs.

**POWER RACK-AND-PINION STEERING** Power rack-and-pinion steering provides Sierra 1500 models with a positive on-center feel at highway speeds, as well as extra low-speed assist for maneuvering in tight spaces.

**STABILITRAK** A stability control system that's standard on all Single Rear Wheel (SRW) Sierra models, StabiliTrak senses when your vehicle is not responding to your steering inputs and adjusts engine speed and applies brake pressure to any individual wheel to help maintain directional control.



## SIERRA HD

**9 SIERRA HD FRAME** Not just a beefed-up light-duty frame, the Sierra HD frame is specifically engineered for HD use. Crafted from high-strength steel, the HD frame is fully boxed along its entire length, with fully welded (not riveted) brackets and cross-members. Tubular cross-members are through-rail welded for significantly added strength and resistance to twisting over rough surfaces.

**INDEPENDENT FRONT SUSPENSION** For ride comfort without sacrificing strength, Sierra HDs have an independent front suspension designed specifically for the constant punishment of heavy-duty use. With an available unsurpassed pickup Gross Front Axle Rating of up to 6000 lbs,<sup>1</sup> this torsion-bar suspension design allows you to make seasonal ride-height adjustments in minutes, with a single wrench.

<sup>1</sup>Capabilities and weight ratings are dependent upon model, engine, transmission and GVWR combinations. See your GMC dealer for details.

**10 MULTILEAF REAR SPRINGS** The more load Sierra HD takes, the more its springs step up to the task. To handle heavy-duty payloads, GMC engineers specced out Sierra HD models with rear leaf springs that are 3 inches wide—two-stage for 2500HD models and three-stage for 3500HD models.

**TORSION BAR DESIGN** The Sierra HD frame uses torsion bar suspension. Pioneered for pickups by GMC, the torsion bar is designed to support different front axle loads and to retain proper trim height.

#### HEAVY-DUTY POWER STEERING

Sierra HD models feature recirculating ball power steering. The high-capacity power steering pump and large reservoir help to give a constant level of assist, even when operating at the maximum weight.

**DIESEL EXHAUST BRAKE** To let you engage an extra measure of braking confidence on long grades, the diesel exhaust brake, included with the available Duramax Diesel engine, uses engine compression to create "negative torque" to help slow the vehicle. It is factory installed and calibrated to work with the rest of your Sierra HD's braking system.

**HYDRAULIC BODY MOUNTS** How do you balance the demand for a rigid frame with desire for cabin comfort? GMC engineers positioned the Sierra HD Extended and Crew Cab on rear mounts filled with hydraulic fluid, creating a smooth, quiet ride quality.

**36-GALLON FUEL TANK (approx)** When equipped with the available Duramax Diesel, Sierra HD has a highway range of up to 680 miles on a single tank of fuel,<sup>2</sup> thanks to its 36-gallon fuel tank.

<sup>2</sup>Based on GM testing and fuel tank capacity. Your range may be less.

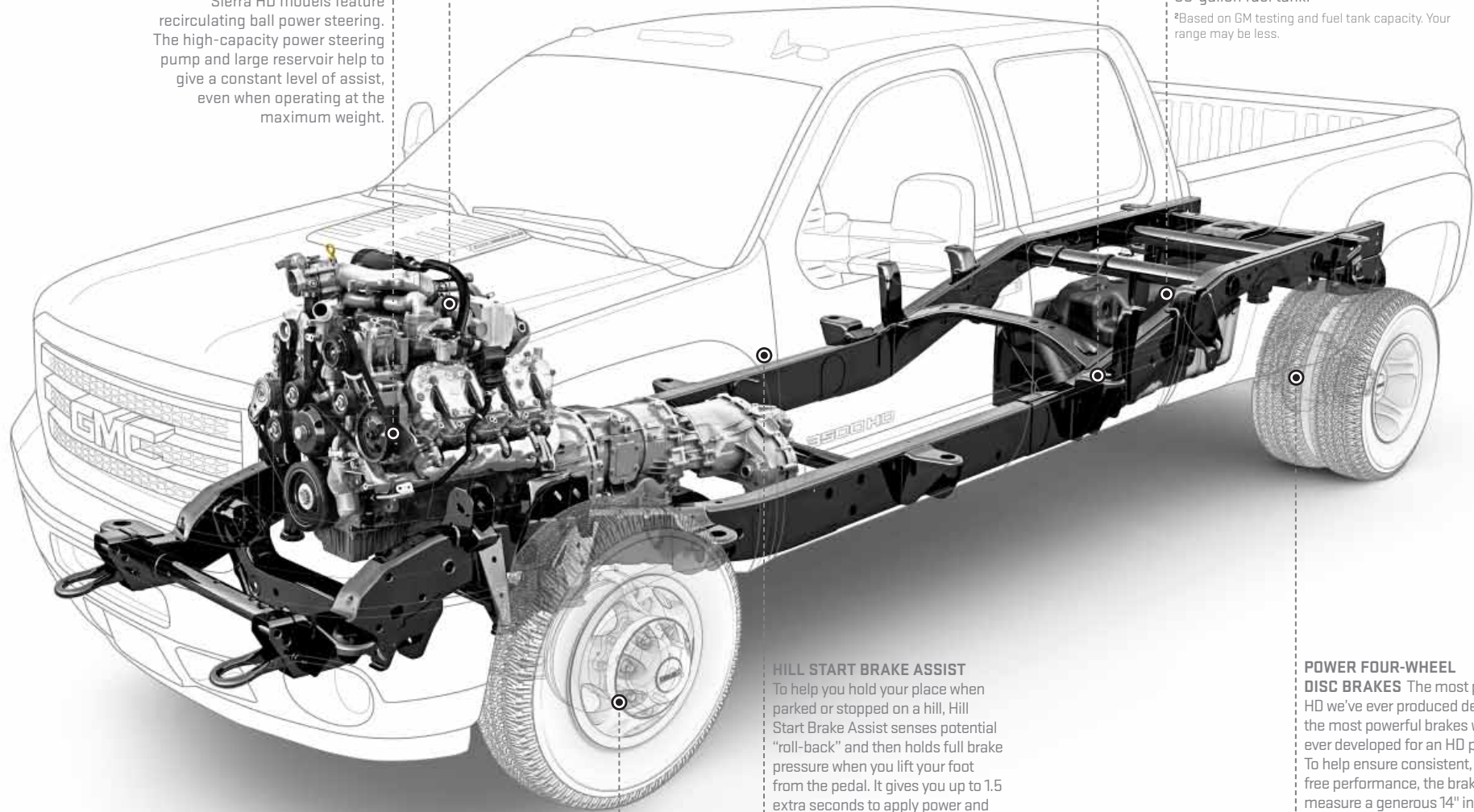

#### ANTILOCK BRAKING SYSTEM (ABS)

For confident stops in a variety of conditions, every Sierra features four-channel antilock brakes. When the brakes are applied, ABS can detect impending wheel lock-up and then pulse that wheel's brake to prevent it. The system can activate any combination of vehicle brakes to maintain control.

#### HILL START BRAKE ASSIST

To help you hold your place when parked or stopped on a hill, Hill Start Brake Assist senses potential "roll-back" and then holds full brake pressure when you lift your foot from the pedal. It gives you up to 1.5 extra seconds to apply power and drive off. (Not available on Hybrid or DRW models.)

#### INTELLIGENT BRAKE ASSIST

In an abrupt stop, milliseconds can be your margin of safety. That's why Sierra's Intelligent Brake Assist senses when you are making an emergency stop, then automatically applies full braking force before your foot can press the pedal all the way. Not available on Dual Rear Wheel (DRW) models.

#### POWER FOUR-WHEEL

**DISC BRAKES** The most powerful HD we've ever produced demanded the most powerful brakes we've ever developed for an HD pickup. To help ensure consistent, fade-free performance, the brake discs measure a generous 14" in diameter and utilize twin piston calipers.



SIERRA 2500HD CREW CAB SLT IN ONYX BLACK shown with available equipment.



# TRAILERING

GMC Sierra and Sierra HD are engineered to offer you professional-grade trailering capability. Whether you're headed out for work or recreation, Sierra offers a wide range of trailering capacities to meet your needs. Complete trailering ratings for Sierra 1500 are listed on page 39, and ratings for Sierra 2500HD and 3500HD models are listed on page 40.

11



**11 MULTI-STAGE REAR LEAF SPRINGS** For big capacity when you need it and a smoother ride when you don't, Sierra HD's 3"-wide multileaf rear springs engage progressively as the load in the bed or on the hitch increases. In 2500HD, it's a 2-stage progression, and on 3500HD, it's 3-stage for added load-bearing capacity.

12

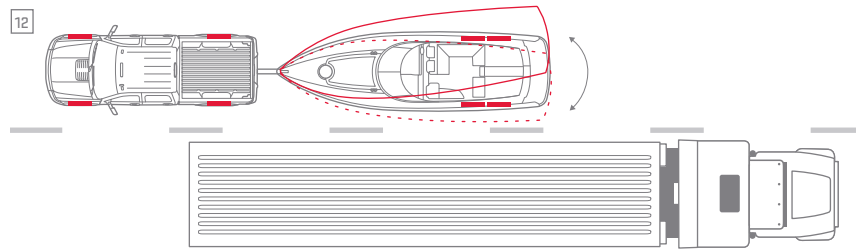

**12 TRAILER SWAY CONTROL** Keep both you and your trailer heading in the proper direction, automatically. This system uses StabiliTrak sensors to detect the rocking of a swaying trailer, and then applies the vehicle's brakes and the trailer's brakes (if properly equipped) to help bring it back in line. The only thing you feel is confidence. (Trailer Sway Control not available on Hybrid or DRW models.)

13



**13 TRAILER BRAKE CONTROLLER** For fingertip control and easy monitoring of your trailer brakes, Sierra offers an integrated trailer brake controller. It is located close to the steering wheel for easy adjustments and displays the level of brake force or "gain" in the Driver Information Center. (Not available on Hybrid, standard on 3500HD models.)



**FIFTH-WHEEL FRAME MOUNT PROVISIONS** Sierra HD models offer easy installation of fifth-wheel and gooseneck hitches. GMC engineers added prepierced access holes to preserve frame integrity as well as a pair of extra cross-members for added strength in the hitch-mount location.

## MAXIMUM TRAILER RATINGS<sup>1</sup>

1500	Up To	10,700 lbs
2500HD	Up To	17,800 lbs
3500HD	Up To	23,100 lbs

Complete trailering ratings for Sierra 1500 are listed on page 39, and ratings for Sierra 2500HD and 3500HD are listed on page 40.

<sup>1</sup>Maximum trailer weight ratings are calculated assuming a base vehicle, except for any option(s) necessary to achieve the rating, plus driver. The weight of other optional equipment, passengers and cargo will reduce the maximum trailer weight your vehicle can tow. See your GMC dealer for additional details.

# INTERIOR

Climb into the cab of a GMC Sierra and you'll quickly get the sense that everything that surrounds you has been purpose-built for your needs. From the integration of advanced technologies to the supportive seats to carefully calculated storage bins, Sierra's spacious interior is designed to put the driver in control and the passengers at ease.



**14 HEATED AND COOLED FRONT SEATS** The ultimate in all-weather comfort, these seats are appointed in a perforated leather that allows the cooling feature to circulate air between you and the seat surface. They are standard on Denali and available on SLT models.

**POWER FRONT SEATING** Get comfortable more easily with power-adjustable front seats. Power driver seat adjustment is available for 40/20/40 seating with select equipment packages, and power driver and passenger seats are included with all bucket seats in SLE (6-way), SLT (10-way) and Denali (12-way).

**POWER-ADJUSTABLE PEDALS** To help drivers of varying sizes sit at a comfortable distance from the steering wheel, adjustable pedals with memory are available on SLE and SLT models, and are standard in Denali.

**HEATED STEERING WHEEL** Exclusive to Denali, the leather-wrapped, heated steering wheel adds soothing warmth whenever the driver demands it.

**15 CLIMATE CONTROL** All Sierra models are equipped with air conditioning. Automatic dual-zone climate control with individual settings for the driver and right-front passenger is standard on SLT and Denali, and available on SLE.

**BLUETOOTH®<sup>1</sup> FOR PHONE** Extend your capabilities by activating the available Bluetooth feature. This lets your Bluetooth device work through the vehicle's controls and features already installed in your Sierra, including hands-free operation and dialing.

<sup>1</sup>Go to [gm.com/bluetooth](http://gm.com/bluetooth) to find out which Bluetooth phones are compatible with the vehicle.

**DRIVER INFORMATION CENTER** Staying in touch with the most important vehicle information is as easy as pressing a button. The Driver Information Center includes the odometer and trip odometers, as well as a message center that keeps you informed about vital vehicle functions and driving conditions. SLE, SLT and Denali include a compass and outside temperature indicator.

# CONVENIENCE

Available on GMC Sierra are a number of advanced features that enhance the level of convenience you can enjoy behind the wheel. Each helps transform ordinary tasks – starting the vehicle, searching for a song, reversing into a parking space – seamlessly integrating innovative technologies to create a truly exceptional driving experience.



**16 REAR-VISION CAMERA SYSTEM** Make it easier to back up to a trailer or negotiate a tight space. This available system places a monitor in your rearview mirror (or navigation screen, if equipped) to display a view of the area behind the vehicle. The rear-vision camera does not replace driver vision. Please use proper care when backing up.

**17 REMOTE VEHICLE START** This available feature lets you start your vehicle from up to 195 feet away. Your Sierra will run for up to 10 minutes. If equipped with the automatic climate control system, it will default to heating or cooling mode based on the outside temperature.

**18 UNIVERSAL HOME REMOTE** Never get locked out again. This available remote can be easily programmed to operate the majority of garage-door-opening systems, and has the benefit of never needing batteries.

**19 STEERING-WHEEL-MOUNTED RADIO CONTROLS** Play your audio system with your fingertips, while you keep your eyes on the road. These available fingertip controls can also manage most music search features of compatible MP3 and iPod® players, as well as Bluetooth® for phone.

\*Go to [gm.com/bluetooth](http://gm.com/bluetooth) to find out which Bluetooth phones are compatible with the vehicle.

**ULTRASONIC REAR PARKING ASSIST** This available system sends out ultrasonic waves that act like rear bumper radar to alert you to the distance of objects up to 8 feet behind the vehicle. The system operates at speeds less than 5 mph. The closer you are, the faster it beeps, to give you a clear signal that can help you operate the vehicle with maximum care.

# ENTERTAINMENT

Sierra is available with a range of entertainment technologies to enhance your experience. The quiet passenger cabin is the perfect starting point for you and your passengers to enjoy the available audio and DVD Rear-Seat Entertainment System. Information, music and video—it's all available via controls and touch-screen technology that make finding exactly what you want easy.



**BOSE® AUDIO SYSTEMS** Make the front seat of your Sierra sound like the front row of your favorite concert. Bose systems are engineered to give you the realism and presence of a live performance. Standard on SLT and available on SLE models, Bose Audio features steering-wheel-mounted radio controls and a premium speaker system, with a center console-mounted woofer for rich bass tones that give you a fuller listening experience.

**BOSE CENTERPOINT® SOUND** Denali models have standard Bose Centerpoint surround-sound system with SurroundStage® signal processing for the sensation of a live performance while you drive. This technology, along with AudioPilot® noise compensation, wraps you in sound, delivering five independent channels from existing two-channel recordings.

**AUXILIARY INPUT** This available feature accommodates most MP3 players and devices, including many smartphones. So you can bring the music and entertainment you love to your Sierra just by plugging in.

**20 REAR-SEAT ENTERTAINMENT SYSTEM** Let your rear-seat passengers enjoy the ride in your Sierra even more. Available in SLT and Denali Crew Cab models, this system includes a DVD player and 8" flip-down screen. It also comes with dual-play, which has a separate upper DVD slot in the radio to let front-seat passengers control the DVD or music playing behind them. The system is compatible with most popular video gaming systems.

**DEALER-INSTALLED WI-FI<sup>1</sup>** Connect up to 20 wireless users at one time and stay in touch with your life's vital information with the first wireless router designed just for automotive use. Ask your dealer for specific plans and prices for this available system.

<sup>1</sup>Monthly rates apply. Visit [autonetmobile.com](http://autonetmobile.com) for coverage map and details.

**21 TOUCH-SCREEN NAVIGATION SYSTEM<sup>2</sup>** For easy operation, the available system includes a large 7" in-dash touch-screen display, 2-D or 3-D map graphics and 3 months of NavTraffic.<sup>3</sup> OnStar subscribers can also use this system with OnStar Turn-by-Turn Navigation assistance (6 months standard). For your convenience, this screen also serves as a large, easily read monitor for the available Rear-Vision Camera System. Its sophisticated features include pause-and-play capability for live broadcasts that works like a DVR for enhanced visibility and viewing.

<sup>2</sup>Map coverage for Puerto Rico and the U.S. Virgin Islands available on separate disc. Coverage not available for portions of Canada. <sup>3</sup>If you subscribe after your trial period, *subscriptions are continuous until you call SiriusXM to cancel.* See SiriusXM Customer Agreement for complete terms and geographic limitations at [siriusxm.com](http://siriusxm.com). Other fees and taxes will apply. All fees and programming subject to change.

**USB PORT<sup>4</sup>** Plug your digital devices into the available USB port in the center console.

<sup>4</sup>Not compatible with all devices.

**SiriusXM SATELLITE RADIO/NAVTRAFFIC<sup>5</sup>** Enjoy SiriusXM Satellite Radio in your Sierra with a 3-month trial subscription to the XMPremier Package. Only SiriusXM brings you more of what you love, all in one place. Get over 130 channels, including commercial-free music, plus the best sports, news, talk, comedy and entertainment. With NavTraffic, you'll get continuously updated traffic information as it occurs, right on your vehicle's available navigation system. Welcome to the world of SiriusXM. [Available on WT models.]

<sup>5</sup>If you subscribe after your trial period, *subscriptions are continuous until you call SiriusXM to cancel.* See SiriusXM Customer Agreement for complete terms and geographic limitations at [siriusxm.com](http://siriusxm.com). Other fees and taxes will apply. All fees and programming subject to change.

# ONSTAR

How do more than six million drivers stay safe on the road? With OnStar,<sup>6</sup> our integrated communications system that connects you to a variety of information—and to a real, live Advisor whenever you push the OnStar button on the overhead console. OnStar is technology designed to enhance your safety, security and peace of mind. A 6-month subscription to the OnStar Directions & Connections Plan is standard on most Sierra models (available on WT.)

<sup>6</sup>Visit [onstar.com](http://onstar.com) for coverage map, details and system limitations. OnStar acts as a link to existing emergency service providers. Services vary with conditions.



**DIRECTIONS & CONNECTIONS PLAN<sup>7</sup>** Success in today's fast-moving world means finding and focusing on the information that means the most to you. To put this capability at your fingertips, Sierra comes standard with a 6-month trial subscription to the OnStar Directions & Connections Plan. (Available on WT models.)

<sup>7</sup>Visit [onstar.com](http://onstar.com) for coverage map, details and system limitations. OnStar acts as a link to existing emergency service providers. Services vary with conditions.

**HANDS-FREE CALLING<sup>8</sup> WITH VOICE-ACTIVATED DIALING** Available OnStar Hands-Free Calling is built into your Sierra. Just push a button, call out the number and you're free to keep your eyes on the road. It's reliable, because it is specially designed for better connectivity and fewer dropped calls in areas with limited cellular reception.

<sup>8</sup>Visit [onstar.com](http://onstar.com) for coverage map, details and system limitations. OnStar Hands-Free Calling requires a hands-free calling-enabled vehicle, existing OnStar service contract and prepaid minutes. Not available in certain markets. Calls can be made in U.S. and Canada only.

**TURN-BY-TURN NAVIGATION** Drive with more confidence and certainty. OnStar Turn-By-Turn Navigation is built into OnStar-equipped Sierra models. It's simple—all you have to do is push one button and ask the OnStar Advisor to download directions to your vehicle. Turn-By-Turn is also smart, because an automated voice calls out every turn as you need it.

**22 ONSTAR VEHICLE DIAGNOSTICS<sup>9</sup>** The peace of mind that comes from knowing the condition of your Sierra's key systems is as easy as checking your e-mail. OnStar Vehicle Diagnostics is a service that is standard with your 6-month trial subscription to the Directions & Connections Plan and can run hundreds of checks of your Sierra's engine, transmission, antilock brakes and more, then organize the information in an easy-to-read monthly report. OnStar can also run a check of your vehicle as you drive; just press the blue button and ask the Advisor for an On-Demand

Diagnostics check. That's peace of mind when you need it.

<sup>9</sup>Capabilities vary by model. Visit [onstar.com](http://onstar.com) for details and system limitations.

**DESTINATION DOWNLOAD** Looking for a destination in your screen-based navigation system? OnStar will do it for you. Simply press your blue OnStar button, and you will be connected with a trained Advisor who will download your directions to your Sierra's available screen-based navigation system. You can also have destinations downloaded on the go—no need to pull over to enter new addresses. It's an enhancement to navigation that makes screen-based navigation systems easier and faster to use.

**STOLEN VEHICLE ASSISTANCE** If your Sierra is ever stolen, OnStar can help locate it after verification with law enforcement. OnStar can use built-in GPS technology to help to locate it, prevent it from restarting with Remote Ignition Block or, if the vehicle is in use, engage the Stolen Vehicle Slow-

down technology to help police recover it quickly and safely.

**ROADSIDE ASSISTANCE<sup>10</sup>** If the unexpected happens on the road—you're stranded, run out of gas or have a flat tire—one push of the OnStar button can immediately connect you to an Advisor, ready to help any hour of the day or night. OnStar can use GPS technology to pinpoint your location and connect you to a service provider. No guessing about where you are or what to do.

<sup>10</sup>Roadside service provided by Cross Country.

**REMOTE DOOR UNLOCK** It's happened to everyone. But there is an easy solution. If you get locked out of your Sierra, OnStar can help. After verifying your account, an OnStar Advisor can send a signal to your Sierra that usually unlocks the doors within minutes.<sup>11</sup>

<sup>11</sup>Requires power door locks. Services vary by model and conditions.

**AUTOMATIC CRASH RESPONSE** If your Sierra is in a crash, built-in sensors can automatically send

an alert to OnStar. An OnStar Advisor is immediately connected to your vehicle to help you. Even if you aren't capable of responding, the Advisor can use GPS technology to locate you and request that emergency help is sent right away.

**23 CRISIS ASSIST** During severe weather or other natural disasters, OnStar can offer assistance and help you navigate your way to safety. Just push the red OnStar emergency button and our specially trained Crisis Assist Team moves quickly to help you. OnStar can pinpoint your location and provide up-to-date information from public safety authorities, request that help be sent to you or even contact family members or loved ones.

**EMERGENCY SERVICES** If someone in the vehicle needs emergency help, the OnStar emergency button gives you a priority connection to a specially trained Advisor at any time, day or night. OnStar uses GPS technology to pinpoint your location and

can request police, fire or medical support be sent right away. The Advisor can also stay with you on the line until help arrives.

**24 ONSTAR REMOTELINK APP<sup>12</sup>** The OnStar Remotely app offers an amazing level of control and connection with your vehicle. After downloading and registering the app, GMC owners with an eligible vehicle can use their iPhone<sup>®</sup> or Android<sup>™</sup>-based mobile devices to control their vehicle from their phone and perform specific commands—like unlocking their doors—remotely.<sup>13</sup> You can lock/unlock your doors from any distance, start your vehicle remotely,<sup>14</sup> sound your horn and flash your lights to help locate your vehicle or contact an OnStar Advisor, Roadside Assistance or your preferred dealer. To learn all about all the great features available, go to [onstar.com](http://onstar.com).

<sup>12</sup>Available on iPhone<sup>®</sup>, select Android<sup>™</sup> and BlackBerry<sup>®</sup> platforms. Services vary by phone and conditions. <sup>13</sup>Requires power door locks. <sup>14</sup>Requires factory-installed remote start.

# SAFETY

Sierra is designed to help protect you before, during and after a collision. Advanced chassis control technologies help Sierra drivers avoid potential accidents. A system of air bag supplemental restraints<sup>1</sup> helps protect passengers during a collision. With the available OnStar Automatic Crash Response<sup>2</sup> (standard for 6 months), Sierra can even connect you to help in the critical moments immediately after you're involved in a crash.

<sup>1</sup>Air bag inflation can cause severe injury or death to anyone too close to the air bag when it deploys. Be sure every occupant is properly restrained. Always use safety belts and the correct child restraint for your child's age and size, even with air bags. Even in vehicles equipped with the Passenger Sensing System, children are safer when properly secured in a rear seat in the appropriate infant, child or booster seat. Never place a rear-facing infant restraint in the front seat of any vehicle equipped with an active frontal air bag. See your vehicle Owner's Manual and child safety seat instructions for more safety information. <sup>2</sup>Visit [onstar.com](http://onstar.com) for coverage map, details and system limitations. OnStar acts as a link to existing emergency service providers.

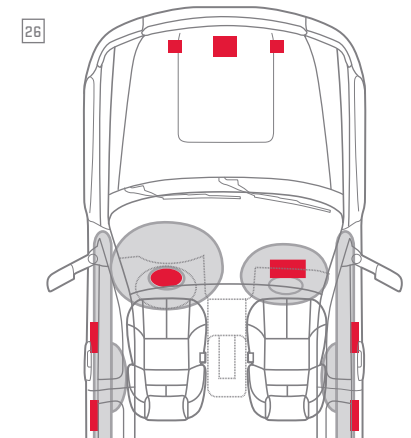

**25 FRONTAL AIR BAGS<sup>3</sup>** All Sierra models come with driver and front-passenger air bags. To help reduce the risk of injury to passengers, Light Duty models come standard with dual-stage frontal air bags that have sensors to gauge the severity of a crash, then determine whether to deploy one or two levels of inflation. Sierra Light Duty models also feature a Passenger Sensing System for the outboard front passenger that automatically turns off the air bag if the passenger is under the appropriate weight.

**26 HEAD CURTAIN SIDE-IMPACT AIR BAGS<sup>3</sup>** These air bags unfurl from the roof rail like a protective curtain for outboard passengers, and can be activated by either rollover sensors or side-impact sensors. They are available on select Heavy Duty models.

<sup>3</sup>Air bag inflation can cause severe injury or death to anyone too close to the air bag when it deploys. Be sure every occupant is properly restrained. Always use safety belts and the correct child restraint for your child's age and size, even with air bags. Even in vehicles equipped with the Passenger Sensing System, children are safer when properly secured in a rear seat in the appropriate infant, child or booster seat. Never place a rear-facing infant restraint in the front seat of any vehicle equipped with an active frontal air bag. See your vehicle Owner's Manual and child safety seat instructions for more safety information.

**SEAT-MOUNTED SIDE-IMPACT AIR BAGS<sup>3</sup>** To help protect the thorax and pelvic regions of the driver and outside front passenger in a side-impact collision, Sierra Light Duty and Heavy Duty Denali models include side-impact air bags mounted on the driver and outside front passenger seat. They are available on select Heavy Duty models.

**LATCH CHILD SEAT ANCHORING SYSTEM** Make it easier to properly install a child seat. LATCH stands for Lower Anchors and Top tethers for CHildren. A LATCH seat will install to specially designed retainer hooks in your Sierra with an audible "click." It also means that you can install a top tether strap that helps limit movement in a forward crash to help reduce the chance of injury.

**REINFORCED STEEL SAFETY CAGE DESIGN** Sierra's robust body structure is engineered to help maintain the integrity of the passenger compartment in the event of a collision. All steel from wheel to wheel, the body is designed to crush in a controlled manner in the event of a collision, absorbing the energy of a crash as much as possible.

**PASS-KEY III+ THEFT DETERRENT SYSTEM** Preventing unauthorized starting attempts in your Sierra comes down to a tiny chip found in your ignition key. It functions as an electronic "fingerprint" that disables your starting system if it detects a theft attempt is underway.

# WHEELS

A selection of strong, stylish GMC wheels in a range of sizes is available to help you tailor your new Sierra precisely to your personal taste. Whether you choose painted steel, chrome-clad aluminum or forged polished aluminum, each wheel features a durable finish designed to withstand the test of time, and many are also available with matching lugs and GMC center caps.



## SIERRA/1500 WHEELS



**NX7**  
17" PAINTED  
STEEL  
STANDARD: WT



**S86**  
20" CHROME-  
CLAD ALUMINUM  
AVAILABLE: SLE  
AND SLT



**RZF**  
18" CHROME-  
CLAD ALUMINUM  
STANDARD:  
ALL-TERRAIN  
PACKAGE



**P41**  
20" CHROME  
ALUMINUM  
STANDARD:  
DENALI



**PY9**  
17" CHROME-  
STYLED STEEL  
STANDARD: SLE  
AND SL CREW CAB  
AVAILABLE: WT  
REGULAR AND  
EXT CAB



**R08**  
18" CHROME-  
CLAD  
ALUMINUM  
STANDARD: SLT  
AND HYBRID



**N88**  
17" POLISHED  
ALUMINUM  
SPORT  
STANDARD: XFE  
AVAILABLE:  
SLE AND SLT  
W/MAX  
TRAILERING  
PACKAGE

## 2500HD WHEELS



**PYN**  
17" PAINTED  
STEEL  
STANDARD: WT



**PYP**  
17" CHROME-  
CLAD STEEL  
AVAILABLE: WT



**PYQ**  
17" CAST-  
ALUMINUM  
BRIGHT  
MACHINED  
STANDARD: SLE



**PYS**  
20" ALUMINUM  
AVAILABLE: SLE  
AND SLT

## 2500HD/3500HD SRW WHEELS



**PYT**  
18" PAINTED  
STEEL  
STANDARD:  
3500HD WT  
AVAILABLE:  
2500HD WT



**PYR**  
18" FORGED  
POLISHED  
ALUMINUM  
STANDARD:  
2500HD SLT,  
3500HD SLE  
AND SLT  
AVAILABLE:  
2500HD SLE

## DENALI HD SRW WHEELS



**PYR**  
18" FORGED  
POLISHED  
ALUMINUM  
STANDARD:  
2500 AND 3500  
DENALI HD



**PYS**  
20" ALUMINUM  
AVAILABLE: 2500  
DENALI HD

## 3500HD DRW WHEELS



**PYW**  
17" PAINTED  
STEEL  
STANDARD: WT



**P06**  
17" CHROME  
SKINS  
AND CENTER  
CAPS  
STANDARD: SLE  
AND SLT



**RS7**  
17" FORGED POL-  
ISHED ALUMINUM  
STANDARD: 3500  
DENALI HD DRW  
AVAILABLE:  
3500HD SLE AND  
SLT DRW

# EXTERIOR COLORS



SIERRA 1500 CREW CAB IN STEEL GRAY METALLIC shown with available equipment.



ONYX BLACK<sup>1</sup>



QUICKSILVER METALLIC



STEEL GRAY METALLIC<sup>1</sup>



SUMMIT WHITE<sup>1</sup>



FIRE RED



STEALTH GRAY METALLIC



SONOMA RED METALLIC<sup>1</sup>

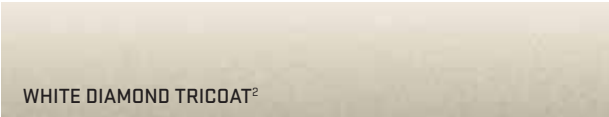

WHITE DIAMOND TRICOAT<sup>2</sup>



HERITAGE BLUE METALLIC



MOCHA STEEL METALLIC

All colors are basecoat/clearcoat for high gloss and durable finish. See dealer for more details on paint and color availability.

<sup>1</sup>Available on Denali. <sup>2</sup>Available on Crew Cab and 1500 Denali.



# INTERIOR COLORS



## VINYL (Standard: WT)



## CLOTH (Standard: SL; Available: WT)



## PREMIUM CLOTH (Standard: SLE, Hybrid and XFE)



## LEATHER-APPOINTED (Standard: SLT; Available: SLE, Hybrid and XFE)



## SIERRA ALL-TERRAIN INTERIOR TRIM Premium Cloth (Standard: SLE)



## PERFORATED LEATHER-APPOINTED (Standard: Denali; Available: SLT)

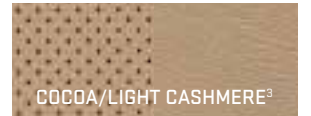

<sup>3</sup>Very Dark Cashmere/Light Cashmere on SLT. <sup>4</sup>Not available on Denali.

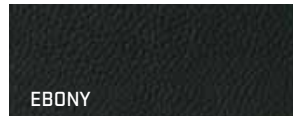
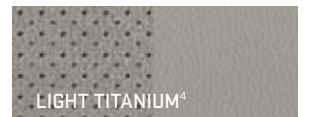
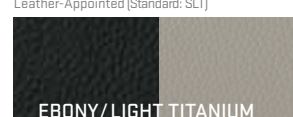
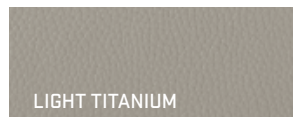

# ACCESSORIES

Engineered to the same standards as your Sierra, GMC Accessories range from functional enhancements like assist steps and bed management systems to a stylish array of accessory chrome wheels and accents. So go ahead, accessorize your Sierra exactly the way you want it.

## 20" AND 22" CAST CHROME WHEELS<sup>1</sup>

Fill up your wheel wells and stand out from the crowd with these factory-engineered and approved wheels from GMC Accessories. Each wheel features a brilliant durable chrome finish and is available with matching lugs and GMC logo center caps.

<sup>1</sup>Use only GM-approved tire and wheel combinations. Unapproved combinations may change the vehicle's performance characteristics. For approved tire and wheel combinations and other important information, go to [gmaccessorieszone.com](http://gmaccessorieszone.com) or see your GMC dealer for details.



CK948 20" CHROME



CK951 20" CHROME



CK997 20" CHROME



CK375 22" CHROME



CK916 22" CHROME



CK370 20" CHROME



CK991 20" CHROME



CK945 20" CHROME



CK366 TRI-SPOKE 22" CHROME



### SOFT TONNEAU COVER

Roll-up design shields cargo, easily rolls up to allow full access to the bed and is constructed with integrated crossbows.



### CHROME MIRROR COVER

Help your Sierra make a fashion statement with these chrome outside rearview mirror covers.



### ASSIST STEPS

Make it easier to get in and out of your truck with these stylish assist steps. Crafted from rust-resistant stainless steel, they are available in either chrome or black powder coat and in 6-inch oval or 3-inch round styles.



### INTEGRATED DVD

A Dual-Player DVD System mounted in back of each front head restraint with wireless headphones gives rear-seat passengers personal entertainment. Single remote control included.



### OVAL-PATTERN CHROME GRILLE

This sporty chrome grille features a chrome mesh center and surround. It replaces the existing grille.



### DEALER-INSTALLED AUTONET WIFI<sup>2</sup>

Turn your Sierra into a mobile hot spot with the first wireless router engineered specifically for automotive use. It can accommodate up to 10 wireless devices at one time, at a range of up to 150 feet, to help you stay connected, whether you're on the job or at your favorite hideaway.

<sup>2</sup>Monthly rates apply. Visit [autonetmobile.com](http://autonetmobile.com) for coverage map and details.



### STATIONARY TOOLBOX

Diamond-patterned toolbox features dual gas shocks for smooth opening and closing and GMC logo.



**BED RAIL CAPS** Give the rails to your Sierra pickup's bed extra protection against wear and tear with these tough-as-nails rail caps.



SIERRA 1500 CREW CAB SLE IN QUICKSILVER METALLIC shown with available equipment and dealer-installed accessories.

## TRIM LEVELS

## CONFIGURATIONS

	WT	SL	SLE	SLT	DENALI
Regular Cab	●	–	●	–	–
Extended Cab	●	●	●	●	–
Crew Cab	●	●	●	●	●

## MECHANICAL SIERRA 1500

<b>ALL-WHEEL DRIVE</b> Electronic automatic system	–	–	–	–	○
<b>ALUMINIZED STAINLESS STEEL EXHAUST</b>	●	●	●	●	●
<b>AUXILIARY EXTERNAL TRANSMISSION OIL COOLER</b> Heavy-duty air-to-oil. On WT models, requires Trailing Package, Snow Plow Prep Package or Heavy-Duty Cooling Package. On SL models, included with Trailing Package. On SLE models, requires Heavy-Duty Trailing Package, Snow Plow Prep Package and 6-speed automatic transmission.	○	○	○	●	●
<b>BATTERY</b> Heavy-duty maintenance-free with 600 cold-cranking amps, rundown protection and retained accessory power	●	●	●	●	●
<b>BRAKES</b> Front disc/rear drum with 4-wheel antilock	●	●	●	●	–
4-wheel disc with 4-wheel antilock	–	–	○	○	●
<b>EATON® HEAVY-DUTY AUTOMATIC LOCKING REAR DIFFERENTIAL</b>	○	○	○	●	●
<b>ENGINE</b> Vortec 4.3L V-6	●	–	–	–	–
Vortec 4.8L V-8 Variable Valve Timing (VVT) FlexFuel	○	●	●	–	–
Vortec 5.3L V-8 VVT FlexFuel with Active Fuel Management	○	–	○	●	–
Vortec 6.2L V-8 VVT FlexFuel	–	–	○	○	●
<b>ENGINE BLOCK HEATER</b>	○	○	○	○	○
<b>EXTERNAL ENGINE OIL COOLER</b> Heavy-duty air-to-oil. Integral to driver side of radiator tank. On WT models, requires Heavy-Duty Trailing Package or Heavy-Duty Cooling Package. On SLE models, requires 6-speed automatic transmission.	○	–	○	●	●
<b>FRAME</b> Fully boxed to the spare tire area, with hydroformed front section	●	●	●	●	●
<b>HEAVY-DUTY COOLING PACKAGE</b> Includes external engine oil cooler, auxiliary external transmission oil cooler, electric fan and heavy-duty radiator. Only available with 6-speed transmission.	○	–	○	●	●
<b>STABILITRAK STABILITY CONTROL SYSTEM</b> With proactive roll avoidance, Intelligent Brake Assist and traction control	●	●	●	●	●
<b>SUSPENSION</b> Coil-over-shock independent front; semi-elliptical 2-stage multileaf springs rear	●	●	●	●	●
<b>HEAVY-DUTY HANDLING/TRAILERING SUSPENSION</b> Requires Heavy-Duty Trailing Package on WT models	○	●	●	●	–
<b>Z71 OFF-ROAD SUSPENSION PACKAGE</b> Includes off-road jounce bumpers, high-capacity air cleaner, Skid Plate Package and Z71 decals on rear quarters	–	–	○	○	–
<b>HIGH-PERFORMANCE SUSPENSION PACKAGE</b> Included with 20" chrome-clad aluminum wheels	–	–	○	○	●
<b>TRANSMISSION</b> 4-speed automatic, electronically controlled	●	●	●	–	–
6-speed automatic, electronically controlled	○	–	○	●	●
Transfer case. On WT and SL models, includes floor-mounted shifter. On SLE and SLT models, includes AutoTrac electronic case with rotary dial controls (4WD models). Electronic transfer case available on WT models.	●	●	●	●	–
<b>TRAILERING</b> Heavy-Duty Trailing Package. Includes trailing hitch platform and 2" receiver, 7-wire harness with independent fused trailing circuits mated to a 7-way sealed connector, wiring harness for aftermarket trailer brake controller (located in the instrument panel harness), single wire for center high-mounted stop lamp, heavy-duty automatic locking rear differential and external transmission oil cooler. On 1500 WT and SLE models equipped with 6-speed transmission, includes Heavy-Duty Cooling Package and external engine oil cooler.	○	○	○	●	●
Integrated trailer brake controller. Not available with Vortec 4.3L V-6. Requires Heavy-Duty Trailing Package.	○	○	○	○	○
<b>TRAILER SWAY CONTROL</b> With Hill Start Brake Assist. Not available on Sierra Hybrid.	●	●	●	●	●
<b>MAX TRAILERING PACKAGE</b> Includes Vortec 6.2L V-8, heavy-duty automatic locking rear differential, Heavy-Duty Handling/Trailing Suspension Package, 9.5" hybrid rear axle, 3.73 rear axle ratio, front and rear disc brakes, Heavy-Duty Trailing Package, fog lamps and 17" polished aluminum wheels. Available on Extended and Crew Cab models only.	–	–	○	○	–

## TRIM LEVELS

## MECHANICAL SIERRA 1500 continued

<b>POWER TECH PACKAGE</b> Includes Vortec 5.3L V-8 SFI FlexFuel engine, heavy-duty automatic locking rear differential, Heavy-Duty Trailing Package, dual-zone automatic air conditioning, Bluetooth®1 for phone, steering-wheel-mounted audio controls, CD/MP3 player, driver 6-way power seat adjuster, front fog lamps, EZ-Lift locking tailgate and 17" aluminum wheels. Available on Extended and Crew Cab models only.	–	–	○	–	–
<b>SKID PLATE PACKAGE</b> Frame-mounted shields. Includes front underbody shield starting behind front bumper and running to first cross-member, protecting front underbody, oil pan, differential case and transfer case. Requires 4WD on WT models. Not available on 2WD SLE and SLT models unless Z71 Off-Road Suspension Package is ordered.	○	○	○	○	●
<b>SNOW PLOW PREP PACKAGE</b> Includes 10-amp power for back-up and roof emergency light, 160-amp alternator, high-flow front bumper, forward lamp wiring harness, provision for cab roof-mounted lamp/beacon, instrument panel jumper wiring harness for electronic trailer brake controller, high-capacity air cleaner, auxiliary external transmission oil cooler and Skid Plate Package (4WD Regular Cab models only)	○	–	○	–	–

## MECHANICAL SIERRA 2500HD/3500HD

<b>ALTERNATOR</b> 125-amp	●	–	●	●	●
160-amp. Included with Snow Plow Prep Package when Vortec 6.0L SFI V-8 is ordered. Requires Vortec 6.0L SFI V-8.	○	–	○	○	○
Dual, 125 amps each. Included with Snow Plow Prep Package when Duramax Diesel 6.6L V-8 Turbo is ordered. Requires Duramax Diesel 6.6L V-8 Turbo engine.	○	–	○	○	○
<b>BATTERY</b> Heavy-duty, maintenance-free with 600 cold-cranking amps, rundown protection and retained accessory power	●	–	●	●	●
Auxiliary heavy-duty, maintenance-free with 600 cold-cranking amps. Not available with Duramax Diesel 6.6L V-8 Turbo engine.	○	–	○	○	○
Heavy-duty, 2 batteries, maintenance-free with 730 cold-cranking amps, with rundown protection and retained accessory power. Included and only available with Duramax Diesel 6.6L V-8 Turbo engine.	○	–	○	○	○
<b>BRAKES</b> Power 4-wheel disc, 4-wheel antilock	●	–	●	●	●
<b>EATON HEAVY-DUTY AUTOMATIC LOCKING REAR DIFFERENTIAL</b> Included with Heavy-Duty Trailing Package. Standard on all 3500HD pickup models.	○	–	○	●	●
<b>ENGINE</b> Vortec 6.0L V-8 VVT FlexFuel with SFI	●	–	●	●	●
Vortec 6.0L V-8 Gaseous (CNG) with hardened valves and valve seats. Requires Extended Cab 2500HD models. Please see your dealer for more details.	○	–	○	○	–
Duramax Diesel 6.6L V-8 Turbo with direct injection and B20 biodiesel capability	○	–	○	○	○
<b>ENGINE BLOCK HEATER</b>	○	–	○	○	○
<b>ENGINE OIL COOLER</b> Heavy-duty external air-to-oil. Integral to driver side of radiator tank.	●	–	●	●	●
<b>EXHAUST</b> Aluminized stainless steel	●	–	●	●	●
<b>EXHAUST BRAKE</b> Included with Duramax Diesel 6.6L V-8 Turbo engine only	○	–	○	○	○
<b>FRAME</b> Fully boxed with hydroformed front section	●	–	●	●	●
10,000-lb GVWR <sup>2</sup> package. Select Sierra 3500HD SRW models. See your dealer for details.	○	–	○	○	○
<b>HIGH-CAPACITY AIR CLEANER</b>	●	–	●	●	●
<b>HIGH IDLE SWITCH</b>	○	–	○	○	○
<b>RADIATOR GRILLE AND FRONT BUMPER OPENINGS COVER</b> For cold weather. Requires Duramax Diesel 6.6L V-8 Turbo engine.	○	–	○	○	○
<b>REAR AXLE</b> 3.73 ratio (except 3500HD 2WD Regular Cab SRW model)	●	–	●	●	●
4.10 ratio. Requires Vortec 6.0L V-8 engine.	○	–	○	○	○
<b>SKID PLATE PACKAGE</b> Frame-mounted shields. Includes front underbody shield starting behind front bumper and running to first cross-member, protecting front underbody, oil pan, differential case and transfer case. Requires 4WD on WT models. Not available on 2WD SLE and SLT models unless Z71 Off-Road Suspension Package is ordered.	○	–	○	○	●

TRIM LEVELS	WT	SL	SLE	SLT	DENALI
-------------	----	----	-----	-----	--------

**MECHANICAL SIERRA 2500HD/3500HD continued**

<b>SNOW PLOW PREP PACKAGE</b> Includes 10-amp power for back-up and roof emergency light, 160-amp alternator (dual 125 amp included with Diesel), high-flow front bumper, forward lamp wiring harness, provision for cab roof-mounted lamp/beacon, instrument panel jumper wiring harness for electronic trailer brake controller, Skid Plate Package (4WD models only) and increased Front Gross Axle Weight Rating (FGAWR). See chart on page 39 for more details.	○	–	○	○	○
<b>STABILITRAK</b> Stability control system. Includes electronic trailer sway control, Intelligent Brake Assist and Hill Start Brake Assist (SRW models only).	●	–	●	●	●
<b>STEERING</b> Power, recirculating ball	●	–	●	●	●
<b>SUSPENSION</b> Front independent with torsion bar	●	–	●	●	●
Rear multileaf springs, semi-elliptic with urethane jounce bumpers	●	–	●	●	●
<b>HEAVY-DUTY HANDLING/TRAILERING SUSPENSION PACKAGE</b>	●	–	●	●	●
<b>Z71 OFF-ROAD SUSPENSION PACKAGE</b> Includes off-road jounce bumpers, Skid Plate Package and Z71 decals on rear quarters	–	–	○	○	○
<b>HEAVY-DUTY TRAILERING PACKAGE</b> Includes trailering hitch platform and 2.5" receiver with 2" adapter, 7-wire harness with independent fused trailering circuits mated to a 7-way sealed connector, wiring harness for aftermarket trailer brake controller (located in the instrument panel harness) and integrated trailer brake controller. Standard on all 3500HD models.	○	–	○	●	●
Integrated trailer brake controller. Requires Heavy-Duty Trailering Package. Standard on all 3500HD models.	○	–	○	●	●
Trailering wiring provisions for camper, fifth-wheel and gooseneck trailers; includes additional 8-way wiring harness routed to front of pickup box. Requires Heavy-Duty Trailering Package.	○	–	○	○	○
<b>TRAILER SWAY CONTROL</b> SRW models only	●	–	●	●	●
<b>TRANSFER CASE</b> With floor-mounted shifter (4WD models)	●	–	–	–	–
Electronic shift with rotary dial controls (4WD models)	–	–	●	●	●
<b>TRANSMISSIONS</b> 6L90-E 6-speed automatic. Standard and only available with Vortec 6.0L V-8.	●	–	●	●	●
Allison 1000 Series 6-speed automatic. Included and only available with Duramax Diesel 6.6L V-8 Turbo.	○	–	○	○	○
<b>TRANSMISSION OIL COOLER</b> Auxiliary external heavy-duty air-to-oil	●	–	●	●	●

**SEATING – ALL MODELS**

<b>SEATS</b> 40/20/40 front split-bench with driver and front-passenger manual recline and center fold-down armrest with storage	●	●	–	–	–
40/20/40 front split-bench with driver and front-passenger manual recline. Center fold-down armrest and lockable storage compartment in seat cushion (includes auxiliary power outlet). Adjustable outboard head restraints on Extended and Crew Cab models.	–	–	●	–	–
Front buckets with 6-way power seat adjusters, manual recline, manual lumbar and adjustable head restraints. Requires Extended or Crew Cab models.	–	–	○	–	–
Front buckets with 10-way power seat adjusters (SLT) or 12-way (Denali) including power lumbar control, heated seat cushions and seatbacks, 2-position driver memory (does not apply to lumbar adjuster on SLT) and adjustable head restraints. Includes floor console and storage pockets.	–	–	–	●	●
Heated and cooled perforated leather-appointed seating with 12-way seat adjuster for driver and front passenger. Includes seat-mounted side-impact air bags <sup>3</sup> on SLT and Denali HD SRW models.	–	–	–	○	●
Driver-side manual seat adjuster with lumbar control. On WT models, included and only available with Dark Titanium Cloth seat trim.	○	●	●	–	–
Folding rear bench, full width. Extended Cab models only.	●	●	–	–	–
60/40 folding rear bench. WT and SL require Crew Cab models. SLE requires Extended or Crew Cab models. Not available on Sierra Hybrid.	●	●	●	●	●

TRIM LEVELS	WT	SL	SLE	SLT	DENALI
-------------	----	----	-----	-----	--------

**SEATING – ALL MODELS continued**

<b>SEAT TRIM</b> Dark Titanium vinyl with Graphite-colored rubberized vinyl floor covering	●	–	–	–	–
Dark Titanium Cloth	○	●	–	–	–
Premium Cloth	–	–	●	–	–
Front leather-appointed seating. Includes 6-way power driver seat adjuster on SLE models. Not available on Regular Cab models.	–	–	○	●	–
Premium front leather-appointed seating, Nuance	–	–	–	–	●

**INSTRUMENTATION AND CONTROLS – ALL MODELS**

<b>CRUISE CONTROL</b>	●	●	●	●	●
<b>INSTRUMENTATION</b> Analog cluster with speedometer, fuel level, engine temperature and tachometer. On SLE, SLT and Denali models, includes voltmeter and oil pressure indicators.	●	●	●	●	●
Driver Information Center with odometer, trip odometer and message center. On SLE, SLT and Denali models, includes compass and outside temperature.	●	●	●	●	●
<b>POWER-ADJUSTABLE PEDALS</b> Requires Convenience Package	–	–	○	○	●
<b>REAR-VISION CAMERA SYSTEM</b> With inside rearview mirror display; if Touch-Screen Navigation is ordered, camera display is on NAV screen. Requires locking tailgate. On SLE models, also requires SLE Preferred Package. Not available on Regular Cab models.	–	–	○	○	●
<b>STEERING WHEEL</b> Tilt-Wheel adjustable steering column with brake/transmission shift interlock	●	●	●	●	●
Leather-wrapped (color-keyed on Denali). On WT and SL models, requires Bluetooth <sup>1</sup>	○	○	●	●	●
Steering-wheel-mounted audio controls. On WT and SL models, requires Bluetooth <sup>1</sup> On SLE models, requires Preferred Package.	○	○	○	●	●
Heated, leather-wrapped and color-keyed	–	–	–	–	●
<b>ULTRASONIC REAR PARKING ASSIST</b> With audible warning. Requires Extended or Crew Cab models. Requires Convenience Package.	–	–	○	○	●

**INTERIOR DETAILS – ALL MODELS**

<b>CARPETING</b> Color-keyed with rubberized vinyl floor mats. Extended and Crew Cab models also include rear floor mats; WT models require Dark Titanium Cloth seat trim.	○	●	●	●	–
Color-keyed with removable carpeted floor mats for first and second rows	–	–	–	–	●
<b>CLIMATE CONTROL</b> Single-zone manual air conditioning	●	●	●	–	–
Dual-zone automatic air conditioning with individual settings for driver and right-front passenger; not available with Regular Cab models. Requires Preferred Package.	–	–	○	●	●
<b>DEFOGGER</b> Rear window. Not available with power-sliding rear window.	○	○	○	●	●
<b>FLOOR COVERING</b> Rubberized vinyl	●	○	○	–	–
<b>REARVIEW MIRROR</b> With manual day/night adjustment	●	●	●	–	–
Auto-dimming. Standard on SLE 3500HD models.	–	–	○	●	●
<b>SUNROOF</b> Power with express-open. Includes Universal Home Remote. Crew Cab models only.	–	–	–	○	○
<b>WINDOWS</b> Power with driver express-down. SLT and Denali models include front passenger express-down.	–	●	●	●	●
Rear-access-door, power. Requires Extended Cab models.	–	–	●	●	–
Rear, power-sliding. Not available on Regular Cab models or with rear-window defogger.	–	–	○	○	○

<sup>1</sup>Go to gm.com/bluetooth to find out which Bluetooth phones are compatible with the vehicle. <sup>2</sup>When properly equipped; includes weight of vehicle, passengers, cargo and equipment. <sup>3</sup>Always use safety belts and the correct child restraint for your child's age and size, even with air bags. Even in vehicles equipped with the Passenger Sensing System, children are safer when properly secured in a rear seat in the appropriate infant, child or booster seat. Never place a rear-facing infant restraint in the front seat of any vehicle equipped with an active frontal air bag. See your vehicle Owner's Manual and child safety seat instructions for more safety information.

TRIM LEVELS

OPTION PACKAGES – SIERRA 1500

	WT	SL	SLE	SLT	DENALI
<b>WORK TRUCK PREFERRED PACKAGE</b> Includes power door locks, remote keyless entry, EZ-Lift locking tailgate and Solar-Ray deep-tinted glass. Requires Regular or Extended Cab models.	○	–	–	–	–
<b>WORK TRUCK PLUS PACKAGE</b> Includes 17" chrome-styled steel wheels, chrome surround grille and fog lamps. Requires 1500 Regular or Extended Cab models. On 2WD models, also includes front frame-mounted recovery hooks.	○	–	–	–	–
<b>SLE CONVENIENCE PACKAGE</b> Includes power-adjustable pedals, Universal Home Remote, remote vehicle starter system, Ultrasonic Rear Parking Assist and rear-window defogger. Requires Extended or Crew Cab models.	–	–	○	–	–
<b>SLE PREFERRED PACKAGE (REGULAR CAB)</b> Includes remote vehicle starter system, steering-wheel-mounted controls, Bluetooth <sup>1</sup> for your cell phone, CD/MP3 player, fog lamps, EZ-Lift locking tailgate and 17" polished aluminum wheels	–	–	○	–	–
<b>SLE PREFERRED PACKAGE (EXTENDED OR CREW CAB)</b> Includes steering-wheel-mounted controls, dual-zone automatic air conditioning, 6-way power driver seat adjuster, Bluetooth <sup>1</sup> for your cell phone, CD/MP3 player, fog lamps and EZ-Lift locking tailgate	–	–	○	–	–
<b>SLE WHITE DIAMOND EDITION (CREW CAB ONLY)</b> Includes White Diamond Tricoat exterior color, factory-installed chrome mirror caps and door handles (except tailgate) and bodyside moldings with chrome accent. Not available with outside heated power-adjustable vertical camper mirrors, Body-Color All-Terrain Package, Chrome Essentials Package or All-Terrain Package.	–	–	○	–	–
<b>SLT WHITE DIAMOND EDITION (CREW CAB ONLY)</b> Includes White Diamond Tricoat exterior color, High-Performance Suspension Package, 20" chrome-clad aluminum wheels (S86), <sup>2</sup> chrome recovery hooks, highly polished exhaust tip, factory-installed chrome mirror caps and door handles (except tailgate) and bodyside moldings with chrome accent. Not available with outside heated power-adjustable vertical camper mirrors, Z71 Off-Road Suspension Package, Max Trailering Package, Body-Color All-Terrain Package, Chrome Essentials Package or All-Terrain Package.	–	–	–	○	–
<b>ALL-TERRAIN PACKAGE</b> Includes Z71 Off-Road Suspension Package, Heavy-Duty Trailering Package, inside rearview auto-dimming mirror, 18" x 8" chrome-clad aluminum wheels, P265/65R18 on-/off-road blackwall tires, outside heated power-adjustable power-folding body-colored mirrors, fog lamps, Rancho® brand shocks, body-colored side moldings with chrome accents, unique 4-bar horizontal grille insert with chrome surround, "All Terrain" badging on the front fenders, carpeted floor mats with embroidered "All Terrain" logo, unique sill plates, unique instrument cluster with Z71 logo and mechanical brushed aluminum accents for instrument panel, center console and switch trim plates. Requires Extended or Crew Cab models.	–	–	○	○	–
<b>BODY-COLOR ALL-TERRAIN PACKAGE</b> Includes All-Terrain Package content, plus body-color 4-bar horizontal grille and surround, body-color door handles, mirror caps, front and rear painted bumpers and 20" chrome-clad aluminum wheels (S86). <sup>2</sup> Requires Extended or Crew Cab models.	–	–	○	○	–
<b>CHROME ESSENTIALS PACKAGE</b> Includes 6" chromed tubular oval assist steps, polished exhaust tip, chrome recovery hooks, chrome door handles and mirror caps and 18" chrome-clad aluminum wheels. Not available on Long Box Extended Cab models.	–	–	○	○	–

OPTION PACKAGES – SIERRA 2500HD/3500HD

<b>WORK TRUCK PREFERRED PACKAGE</b> Includes Solar-Ray deep-tinted glass and fog lamps. On 2500HD models, includes 17" chrome-clad steel wheels.	○	–	–	–	–
<b>SLE PREFERRED PACKAGE (REGULAR CAB)</b> Includes remote vehicle starter system, steering-wheel-mounted controls, Bluetooth <sup>1</sup> for your cell phone, CD/MP3 player, fog lamps and EZ-Lift locking tailgate	–	–	○	–	–
<b>SLE PREFERRED PACKAGE (EXTENDED OR CREW CAB)</b> Includes steering-wheel-mounted controls, dual-zone automatic air conditioning, 6-way power driver seat adjuster, Bluetooth <sup>1</sup> for your cell phone, CD/MP3 player, fog lamps and EZ-Lift locking tailgate	–	–	○	–	–
<b>SLE PREMIUM PACKAGE (EXTENDED OR CREW CAB)</b> Includes 20" forged polished aluminum wheels, outside heated power-adjustable vertical camper mirrors, heavy-duty trailering equipment, heavy-duty automatic locking rear differential, dual-zone automatic air conditioning, Bluetooth <sup>1</sup> for your cell phone, steering-wheel-mounted audio controls, AM/FM stereo with CD player and MP3 playback, driver 6-way power seat adjuster, front fog lamps, EZ-Lift locking tailgate, inside rearview auto-dimming mirror, 6" oval chromed tubular assist steps, bodyside moldings with chrome accents and chrome door handles. Not available with SLE Preferred Package.	–	–	○	–	–
<b>SLE CONVENIENCE PACKAGE</b> Includes power-adjustable pedals, Universal Home Remote, remote vehicle starter system, rear-window defogger and Ultrasonic Rear Parking Assist	–	–	○	–	–
<b>SLT CONVENIENCE PACKAGE</b> Includes Universal Home Remote, power-adjustable pedals, EZ-Lift locking tailgate, Ultrasonic Rear Parking Assist and rear wheelhouse liner (dealer installed)	–	–	–	○	–

TRIM LEVELS

ENTERTAINMENT/COMMUNICATION/NAVIGATION – ALL MODELS

	WT	SL	SLE	SLT	DENALI
<b>AM/FM STEREO</b> With seek-and-scan and digital clock	●	–	–	–	–
With MP3-compatible CD player	○	●	●	–	–
With CD player and MP3 playback, USB port <sup>3</sup> and auxiliary input jack. On SLE models, requires SLE Preferred Package.	–	–	○	●	–
With MP3-compatible 6-disc CD player, USB port <sup>3</sup> and auxiliary input jack	–	–	–	○	●
With MP3-compatible CD/DVD player and USB port. <sup>3</sup> On SLT models, requires Crew Cab model and Rear-Seat Entertainment Package. On Denali models, requires Rear-Seat Entertainment Package.	–	–	–	○	○
<b>TOUCH-SCREEN NAVIGATION<sup>4</sup></b> With CD or DVD player and MP3 playback, color touch-screen display, enhanced HDD-based navigation with voice recognition, memory available for music storage, USB port. <sup>3</sup> Radio Data System (RDS) <sup>5</sup> and pause/play radio. Touch-Screen Navigation with DVD player requires Rear-Seat Entertainment Package.	–	–	–	○	○
<b>BOSE® AUDIO PREMIUM SPEAKER SYSTEM WITH SUBWOOFER</b> On SLE models, requires front bucket seats and SLE Preferred Package or Power Tech Package on 1500 models	–	–	○	●	●
Centerpoint® Surround Sound System	–	–	–	–	●
<b>REAR-SEAT ENTERTAINMENT PACKAGE</b> Rear-seat DVD player with LCD display and 2 sets of wireless headphones. Includes rear audio controls. Requires Crew Cab models. On SLT models, includes CD/DVD player. Upgradable to CD/DVD player with navigation. On Denali models, requires CD/DVD player or CD/DVD player and HDD-based navigation.	–	–	–	○	○
<b>SIRIUSXM SATELLITE RADIO<sup>6</sup></b> Including 3 trial months of service	○	●	●	●	●
<b>NAVTRAFFIC<sup>6</sup></b> Including 3 trial months of service. Included and only available with Touch-Screen Navigation. <sup>4</sup>	–	–	–	○	○
<b>BLUETOOTH FOR PHONE<sup>1</sup></b> Personal cell-phone connectivity to vehicle audio system allowing hands-free calling	○	○	○	●	●
<b>ONSTAR</b> Directions & Connections Plan. <sup>7</sup> 6-month subscription.	○	●	●	●	●

CONVENIENCE FEATURES – ALL MODELS

<b>POWER DOOR LOCKS</b> With remote keyless entry (2 transmitters, panic button and content theft alarm). Remote keyless entry does not lock/unlock tailgate. Standard on Crew Cab models.	○	●	●	●	●
<b>REMOTE START</b> With remote keyless entry	–	–	○	●	●
<b>UNIVERSAL HOME REMOTE</b>	–	–	○	○	●

EXTERIOR STYLING AND FUNCTIONALITY – ALL MODELS

<b>BODYSIDE MOLDINGS</b> Body-colored. Chrome insert on Denali models. Not available on Regular Cab DRW models.	–	●	●	●	●
<b>BUMPERS</b> Chrome. On Sierra 1500 WT models, includes black bumper top caps. On SL, SLE and SLT models, includes body-color bumper top caps.	●	●	●	●	–
Front, body-colored	–	–	–	–	●
Rear, chrome step-style with pad	●	●	●	●	–
Rear, body-colored step-style with pad	–	–	–	–	●
<b>DOOR HANDLES</b> Chrome	–	–	–	–	●
<b>EZ-LIFT LOCKING TAILGATE</b>	○	○	○	○	●
<b>FRONT LICENSE PLATE BRACKET</b> Included in all states that require a front license plate	○	○	○	○	○
<b>GLASS</b> Solar-Ray deep tinted	○	●	●	●	●
<b>GRILLE SURROUND</b> Black. 1500 WT models only.	●	–	–	–	–
Chrome grille surround with black horizontal bars. 2500HD and 3500HD WT models only.	●	–	–	–	–
Chrome grille surround with chrome horizontal bars. On WT models, requires Work Truck Plus Package. On Denali models, includes unique chrome upper and lower.	○	●	●	●	●
<b>LIGHTS</b> Halogen front fog lamps. On WT and SLE models, requires Preferred Package.	○	–	○	●	●
Dual cargo area lamps	●	●	●	●	●
<b>RECOVERY HOOKS</b> Front, frame-mounted; standard on 1500 4WD and Denali models. Standard on HD models. Requires All-Terrain Package on 2WD 1500 models.	●	●	●	●	●
Chrome (1500 models only). Requires Chrome Essentials Package.	–	–	○	○	–
<b>SPRAY-IN BEDLINER</b> Available on 2500HD and 3500HD Crew Cab Standard and Long Box models only. Available 4th quarter 2012. See your dealer for details.	○	–	○	○	○
<b>TIRE CARRIER</b> Outside spare, winch-type	●	●	●	●	●
<b>WIPERS</b> Wet-arm front intermittent	●	●	●	●	●

TRIM LEVELS	WT	SL	SLE	SLT	DENALI
<b>OUTSIDE MIRRORS – ALL MODELS</b>					
Manual-folding, black (1500 and 2500HD models)	●	–	–	–	–
Heated power-adjustable, manual-folding, black (1500 and 2500HD models only)	○	●	●	–	–
Heated power-adjustable/power-folding. With integrated turn signal indicators and driver-side auto-dimming; body-color. Not available on 2500HD SLE models. On Light Duty SLE models, requires All-Terrain Package.	–	–	○	●	●
<b>VERTICAL CAMPER</b> Manual-folding with lower convex spotter glass. Standard on 3500HD models. Available on 1500 and 2500HD models.	○	–	–	–	–
Heated, power-adjustable with integrated turn signal indicators; manual-folding/extension; black (convex glass is not heated or power adjustable). SLE 1500 and 2500HD models require inside rearview auto-dimming mirror or inside rearview auto-dimming mirror with camera display. Standard on 3500HD SLE, SLT and Denali models. Not available on Denali 1500 models.	–	–	○	○	○

<b>SAFETY</b>					
<b>AIR BAGS</b> <sup>8</sup> Frontal, includes Passenger Sensing System. On 2500HD and 3500HD models, standard with front driver and passenger single-stage air bag	●	●	●	●	●
<b>Head curtain, front and rear, side-impact</b>					
1500 models	●	●	●	●	●
2500HD models	○	–	○	○	●
3500HD models (SRW only)	○	–	○	○	●
<b>Seat-mounted, thorax and pelvic, side-impact for driver and outboard front-passenger</b>					
1500 models	●	●	●	●	●
2500HD models	○	–	○	○	●
3500HD models (SRW only)	○	–	○	○	●
<b>TIRE PRESSURE MONITORING SYSTEM</b> (Does not monitor spare tire.) Standard on 3500HD models with GVWR <sup>9</sup> less than 10,000 lbs.	●	●	●	●	●
<b>DAYTIME RUNNING LAMPS</b> With automatic lamp control	●	●	●	●	●

### SIERRA 1500 XFE FEATURES AND SPECIFICATIONS

Includes SLE standard content with the following changes / requirements:	
ALUMINUM BLOCK Vortec 5.3L V-8 VVT FlexFuel	
AUTOMATIC TRANSMISSION 6-speed with heavy-duty cooling	
REAR AXLE 3.08 ratio	
ALUMINUM WHEELS N88 17"	
LOW ROLLING-RESISTANCE TIRES	
ALUMINUM LOWER CONTROL ARMS AND SPARE WHEEL	
TONNEAU COVER Soft	
EXTENDED AIR DAM AND OTHER AERO IMPROVEMENTS	
EATON HEAVY-DUTY AUTOMATIC LOCKING REAR DIFFERENTIAL	
HEAVY-DUTY TRAILERING PACKAGE	
<b>FUEL ECONOMY</b>	
EPA-estimated mpg	15 city / 22 hwy
Max. Trailering <sup>10</sup>	7000 lbs
Max. Payload <sup>11</sup>	1648 lbs
GVWR <sup>9</sup>	6700 lbs
GCWR <sup>12</sup>	12,200 lbs

MOST SLE CREW CAB OPTIONS ARE AVAILABLE ON THE SIERRA XFE EXCEPT FOR:

20" WHEELS	
ALL-TERRAIN PACKAGE	
MAX TRAILERING PACKAGE	
Z71 OFF-ROAD SUSPENSION PACKAGE	
POWER TECH EDITION	

### SIERRA 1500 HYBRID MECHANICAL

	3HA	3HB
<b>VORTEC 6.0L V-8 VVT HYBRID</b> With Active Fuel Management, hybrid 2-mode Electronically Variable Transmission and 300-volt DC battery pack	●	●
<b>AUXILIARY POWER MODULE</b> To convert 300-volt battery power to 12-volt	●	●
<b>HYBRID-SPECIFIC COOLING DESIGN</b> Includes a separate powertrain electronics coolant circuit to keep the high-voltage hybrid content cool	●	●
<b>COMBINATION TRANSMISSION COOLER</b> Increases transmission cooling capacity	●	●
<b>EATON HEAVY-DUTY AUTOMATIC LOCKING REAR DIFFERENTIAL</b>	●	●
<b>3.08 AXLE RATIO</b> For optimum highway fuel economy	●	●
<b>HEAVY-DUTY TRAILERING EQUIPMENT</b>	●	●
<b>4-WHEEL DISC BRAKES</b> With 4-wheel Antilock Brake System (ABS) and StabiliTrak	●	●
<b>REGENERATIVE BRAKING SYSTEM</b> Uses hybrid motors in the transmission acting as generators to decelerate the vehicle, while capturing energy for the 300-volt battery pack	●	●
<b>ELECTRIC POWER RACK-AND-PINION STEERING</b> For improved fuel economy and on-center feel	●	●

### EXTERIOR

<b>EZ-LIFT LOCKING TAILGATE</b>	●	●
<b>18" CHROME-CLAD ALUMINUM WHEELS</b>	●	●
<b>MIRRORS</b> Outside heated power-adjustable, black, manual-folding	●	–
Outside heated power-adjustable, power-folding and driver-side auto-dimming, body-color, with integrated turn-signal indicators	–	●
<b>FOG LAMPS</b>	–	●
<b>REAR-WINDOW DEFOGGER</b>	–	●
<b>POWER SUNROOF</b>	–	○
<b>TONNEAU COVER</b> 1-piece soft cover	●	–
3-piece hard cover	–	●
<b>ULTRASONIC REAR PARKING ASSIST</b>	–	●

<sup>1</sup>Go to gm.com/bluetooth to find out which Bluetooth phones are compatible with the vehicle. <sup>2</sup>Use only GM-approved tire and wheel combinations. For approved tire and wheel combinations and other important information, go to gmaccessorieszone.com or see your dealer for details. <sup>3</sup>Not compatible with all devices. <sup>4</sup>Map coverage for Puerto Rico and the U.S. Virgin Islands available on separate disc. Coverage not available for portions of Canada. <sup>5</sup>RDS functions only where stations broadcast RDS information. <sup>6</sup>If you subscribe after your trial period, *subscriptions are continuous until you call SiriusXM to cancel*. See SiriusXM Customer Agreement for complete terms at siriusxm.com. Other fees and taxes will apply. All fees and programming subject to change. For more information about NavTraffic, visit siriusxm.com/navtraffic. For more information about Travel Link, visit siriusxm.com/travellink. XM satellite service is available only to those in the 48 contiguous USA and DC. <sup>7</sup>Visit onstar.com for details and system limitations. <sup>8</sup>Always use safety belts and the correct child restraint for your child's age and size, even with air bags. Even in vehicles equipped with the Passenger Sensing System, children are safer when properly secured in a rear seat in the appropriate infant, child or booster seat. Never place a rear-facing infant restraint in the front seat of any vehicle equipped with an active frontal air bag. See your vehicle Owner's Manual and child safety seat instructions for more safety information. <sup>9</sup>When properly equipped; includes weight of vehicle, passengers, cargo and equipment. <sup>10</sup>Maximum trailer weight ratings are calculated assuming a base vehicle, except for any option(s) necessary to achieve the rating, plus driver. The weight of other optional equipment, passengers and cargo will reduce the maximum trailer weight your vehicle can tow. See your GMC dealer for additional details. <sup>11</sup>Maximum payload capacity includes weight of driver, passengers, optional equipment and cargo. <sup>12</sup>When properly equipped, includes weight of vehicle and trailer combination, including the weight of driver, passengers, fuel, optional equipment and cargo in the vehicle and trailer.

TRIM LEVELS

3HA  
3HB

**SIERRA 1500 HYBRID** *continued*

INTERIOR

<b>40/20/40 SPLIT-BENCH FRONT SEATS</b> Premium Cloth with manual recline with outboard head restraints and center fold-down armrest with storage	●	—
<b>LEATHER-APPOINTED FRONT BUCKET SEATS</b> With driver and passenger 6-way power adjusters	—	●
<b>FOLDING REAR BENCH</b> 3-passenger, full width	●	●
<b>AUTO-DIMMING INSIDE REARVIEW MIRROR</b>	—	●
<b>POWER-ADJUSTABLE PEDALS</b>	—	●
<b>UNIQUE HVAC SYSTEM</b> Features a 300-volt electric air conditioning compressor and electric heater coolant pump. Compressor and pump use no belts, operate even when engine is in Autostop and operate as needed.	●	●
<b>SPECIALLY DESIGNED INSTRUMENTATION</b> Features Autostop / Off indicators and economy gauge	●	●
<b>DRIVER INFORMATION CENTER</b> Includes messages for Hybrid System status	●	●
<b>BOSE AUDIO AND REAR-SEAT AUDIO</b>	—	●
<b>TOUCH-SCREEN NAVIGATION<sup>1</sup></b> With unique hybrid power flow display	—	●
<b>BATTERY BEAUTY COVER</b> Provides a flat load floor and inhibits access to the battery	●	●
<b>DUAL-ZONE AUTOMATIC AIR CONDITIONING</b>	●	●
<b>BLUETOOTH FOR PHONE<sup>2</sup></b>	●	●
<b>REAR-VISION CAMERA SYSTEM</b>	—	●

SAFETY

<b>AIR BAGS<sup>3</sup></b> Frontal, includes Passenger Sensing System	●	●
Head curtain, front and rear, side-impact with rollover sensor	●	●
Seat-mounted, thorax and pelvic, side-impact for driver and outboard front-passenger	●	●
<b>DAYTIME RUNNING LAMPS</b> With automatic lamp control	●	●
<b>TIRE PRESSURE MONITORING SYSTEM</b> (Does not monitor spare tire)	●	●

ENGINE SPECIFICATIONS

<b>VORTEC 6.0L V-8 VVT HYBRID</b>	
HP @ RPM	332 @ 5100
LB-FT TORQUE @ RPM	367 @ 4100
<b>ACTIVE FUEL MANAGEMENT</b>	

TRAILER RATING<sup>4</sup>

2WD	6100 lbs
4WD	5900 lbs

MAX. PAYLOAD RATINGS<sup>5</sup>

2WD	1527 lbs
4WD	1509 lbs

FUEL ECONOMY

2WD (EPA-est. mpg)	20 city / 23 hwy
4WD (EPA-est. mpg)	20 city / 23 hwy

**SIERRA 1500 SPECIFICATIONS**

ENGINES

	VORTEC 4.3L V-6 (LU3)	VORTEC 4.8L V-8 VVT FlexFuel (L20)	VORTEC 5.3L V-8 VVT AFM / FlexFuel Iron Block (LMG)	VORTEC 5.3L V-8 VVT AFM / FlexFuel Alum Block (LC9)	VORTEC 6.2L V-8 VVT FlexFuel (L9H)
CAPACITY	4.3 liters (262 cu. in.)	4.8 liters (293 cu. in.)	5.3 liters (325 cu. in.)	5.3 liters (325 cu. in.)	6.2 liters (376 cu. in.)
SAE NET HORSEPOWER @ RPM	195 @ 4600	302 @ 5600	326 @ 5300 100% E85 315 @ 5200 gasoline or gasoline / E85 mix	326 @ 5300 100% E85 315 @ 5200 gasoline or gasoline / E85 mix	403 @ 5700
SAE NET TORQUE @ RPM (LB-FT)	260 @ 2800	305 @ 4600	348 @ 4400 100% E85 335 @ 4000 gasoline or gasoline / E85 mix	348 @ 4400 100% E85 335 @ 4000 gasoline or gasoline / E85 mix	417 @ 4300
ENGINE / MODEL AVAILABILITY					
Regular Cab, Standard Box	●	○	○	—	—
Regular Cab, Long Box	●	○	○	—	—
Extended Cab, Standard Box	● (2WD)	● (4WD)	○ (2WD)	○ (4WD)	—
Extended Cab, Long Box	—	—	●	—	—
Crew Cab, Short Box	—	●	● (2WD)	○ (4WD) / ● on XFE	○
Crew Cab, Short Box (Denali)	—	—	—	—	●
FUEL ECONOMY (city/hwy mpg)					
2WD	15/20	14/19	15/21	15/21 (15/22 XFE)	13/18
4WD	14/18	13/18	15/21	15/21	12/18

TRANSMISSIONS: <sup>1</sup>500: Electronic 4-speed automatic with overdrive and Tow/Haul mode is standard on 4.3L V-6 and 4.8L V-8. Electronically controlled 6-speed automatic transmission with overdrive, electronic engine grade braking and Tow/Haul mode included and only available on 5.3L V-8 and 6.2L V-8. Denali: Electronically controlled 6-speed automatic transmission with overdrive, electronic engine grade braking and Tow/Haul mode.



**SIERRA 1500 SPECIFICATIONS continued**
**FRONT SUSPENSION<sup>6</sup> COIL-OVER-SHOCK**

FRONT AXLE CAPACITY (Short/Standard/Long Box)	2WD	4WD (Denali: AWD)
Regular Cab (lbs)	- / 3200 / 3300	- / 3950 / 3950
Extended Cab (lbs)	- / 3600 / 3700	- / 3950 / 3950
Crew Cab (lbs)	3650 / - / -	3950 / - / -
Crew Cab: Denali (lbs)	3950 / - / -	3950 / - / -

FRONT SPRING CAPACITY		
Regular Cab (lbs)	- / 3200 / 3300	- / 3950 / 3950
Extended Cab (lbs)	- / 3600 / 3700	- / 3950 / 3950
Crew Cab (lbs)	3650 / - / -	3950 / - / -
Crew Cab: Denali (lbs)	3950 / - / -	3950 / - / -

**REAR SUSPENSION<sup>6</sup> SEMI-ELLIPTICAL 2-STAGE MULTILEAF SPRINGS**

REAR AXLE CAPACITY (Short/Standard/Long Box)	2WD	4WD (Denali: AWD)
Regular Cab (lbs)	- / 3750 / 3750	- / 3750 / 3950
Extended Cab (lbs)	- / 3750 / 3950	- / 3950 / 3950
Extended Cab with Max Trailering Package (lbs)	- / 4200 / -	- / 4200 / -
Crew Cab (lbs)	3950 / - / -	4000 / - / -
Crew Cab: Denali (lbs)	4000 / - / -	4000 / - / -

REAR SPRING CAPACITY		
Regular Cab (lbs)	- / 3750 / 3750	- / 3750 / 4000
Extended Cab (lbs)	- / 3750 / 3950	- / 3950 / 3950
Crew Cab (lbs)	3950 / - / -	3950 / - / -
Crew Cab with Max Trailering Package (lbs)	4200 / - / -	4200 / - / -
Crew Cab: Denali (lbs)	3950 / - / -	3950 / - / -

CARGO DIMENSIONS <sup>7</sup>	SHORT BOX	STANDARD BOX	LONG BOX
Cargo Volume	53.2 cu. ft.	60.7 cu. ft.	75.5 cu. ft.
Inside Width at Floor	62.4"	62.4"	62.4"
Box Length at Floor	69.3"	78.9"	97.8"

EXTERIOR DIMENSIONS	REGULAR CAB	EXTENDED CAB	CREW CAB
Height	73.5"-73.8"	73.6"-73.9"	73.7"-73.8"
Overall Length			
Short Box	-	-	230.2"
Standard Box	205.6"	230.2"	-
Long Box	224.5"	249.2"	-

WHEELBASE	REGULAR CAB	EXTENDED CAB	CREW CAB
Short Box	-	-	143.5"
Standard Box	119.0"	143.5"	-
Long Box	133.0"	157.5"	-

**STANDARD TECHNICAL DATA**

	All models: Power 4-wheel antilock braking system		
Series/Drive Type	1500 / 2WD	1500 / 4WD	DENALI 2WD/AWD
BRAKES	Front disc / rear drum	Front disc / rear drum	4-wheel disc
STEERING	Power rack-and-pinion		
FUEL TANK CAPACITY (Approx gals.: Short/Standard/Long Box)	26.0 / 26.0 / 34.0	26.0 / 26.0 / 34.0	26.0
ALTERNATOR (amps)	145	145	145
GVWR <sup>8</sup> (Gross Vehicle Weight Rating)			
Regular Cab (lbs)	6400	6400-6800	-
Extended Cab (lbs)	6400-7000	7000-7200	-
Crew Cab (lbs)	6800-7100	7000-7300	6800-7000

**MAXIMUM PAYLOAD<sup>5</sup>**

SELECT RATINGS All capacities in lbs

	2WD / 4WD
Regular Cab Standard Box	1940/1714
Regular Cab Long Box	1804/1827
Extended Cab Standard Box	1908/1835
Extended Cab Long Box	1641/1513
Crew Cab: 1500	1634/1712
Crew Cab: 1500 Max Trailering Package	1937/1890
Crew Cab: 1500 XFE	1648/-
Crew Cab: Denali	1589/1623
Hybrid	1527/1509

**MAXIMUM CONVENTIONAL TRAILERING<sup>4</sup>**

	2WD	4WD (Denali: AWD)
Regular Cab Standard Box	9100 with 5.3L / 3.42 axle	8900 with 5.3L / 3.42 axle
Regular Cab Long Box	10,000 with 5.3L / 3.42 axle	9800 with 5.3L / 3.42 axle
Extended Cab Standard Box	10,700 with 6.2L / 3.73 axle	10,400 with 6.2L / 3.73 axle
Extended Cab Long Box	9500 with 5.3L / 3.42 axle	9300 with 5.3L / 3.42 axle
Crew Cab: 1500	9600 with 5.3L / 3.42 axle	9500 with 5.3L / 3.42 axle
Crew Cab: 1500 Max Trailering Package	10,600 with 6.2L / 3.73 axle	10,400 with 6.2L / 3.73 axle
Crew Cab: 1500 XFE	7000 with 5.3L / 3.08 axle	-
Crew Cab: Denali	9600 with 6.2L / 3.42 axle	9400 with 6.2L / 3.42 axle
Hybrid	6100 with 6.0L / 3.08 axle	5900 with 6.0L / 3.08 axle

**SIERRA AXLE RATINGS AND PLOW WEIGHTS**
**FRONT GROSS AXLE WEIGHT RATING (FGAWR) WITH SNOW PLOW PREP PACKAGE (4WD MODELS ONLY)**

BODY	ENGINE RPO	ENGINE TYPE	1500	2500HD	3500HD SRW	3500HD DRW
Regular Cab	L20	Gas	3950	-	-	-
	LMG	Gas	3950	-	-	-
	L96	Gas	-	5200	5600	5600
	LML	Diesel	-	6000	6000	6000
Extended Cab Standard Box	L96	Gas	-	5200	-	-
	LML	Diesel	-	6000	-	-
Extended Cab Long Box	L96	Gas	-	5600	5600	5600
	LML	Diesel	-	6000	6000	6000
Crew Cab Standard Box (includes Denali)	L96	Gas	-	5200	5600	-
	LML	Diesel	-	6000	6000	-
Crew Cab Long Box (includes Denali)	L96	Gas	-	5600	5600	5600
	LML	Diesel	-	6000	6000	6000

**MAXIMUM PLOW WEIGHTS (4WD MODELS ONLY)**

BODY	ENGINE RPO	ENGINE TYPE	1500	2500HD	3500HD SRW	3500HD DRW
Regular Cab	L20	Gas	40/500 <sup>9</sup>	-	-	-
	LMG	Gas	40/500 <sup>9</sup>	-	-	-
	L96	Gas	-	100/925	100/1000	100/1000
	LML	Diesel	-	100/1000	100/975	100/875
Extended Cab Standard Box	L96	Gas	-	100/875	-	-
	LML	Diesel	-	100/925	-	-
Extended Cab Long Box	L96	Gas	-	100/1000	100/1000	100/950
	LML	Diesel	-	100/875	100/825	100/725
Crew Cab Standard Box (includes Denali)	L96	Gas	-	100/850	100/1000	-
	LML	Diesel	-	100/1000	100/875	-
Crew Cab Long Box (includes Denali)	L96	Gas	-	100/1000	100/1000	100/925
	LML	Diesel	-	100/825	100/775	100/700

SRW=Single Rear Wheel DRW=Dual Rear Wheel 100/xxx=100 lbs maximum of permanently attached snow plow mounting hardware/xxx lbs maximum of removable snow plow blade and blade hardware. Maximum plow weights based on a vehicle with average manufacturer option content and 150 lbs each for driver and one additional front-seat occupant. Additional equipment and occupants will reduce maximum plow weight. Rear compensating weight may be required to maintain front axle weight below 65% of total vehicle weight when equipped with snow plow. Consult your snow plow manufacturer for specific compensating weight recommendation.

<sup>1</sup>Map coverage for Puerto Rico and the U.S. Virgin Islands available on separate disc. Coverage not available for portions of Canada. <sup>2</sup>Go to gm.com/bluetooth to find out which Bluetooth phones are compatible with the vehicle. <sup>3</sup>Always use safety belts and the correct child restraint for your child's age and size, even with air bags. Even in vehicles equipped with the Passenger Sensing System, children are safer when properly secured in a rear seat in the appropriate infant, child or booster seat. Never place a rear-facing infant restraint in the front seat of any vehicle equipped with an active frontal air bag. See your vehicle Owner's Manual and child safety seat instructions for more safety information. <sup>4</sup>Maximum trailer weight ratings are calculated assuming a base vehicle, except for any option(s) necessary to achieve the rating, plus driver. The weight of other optional equipment, passengers and cargo will reduce the maximum trailer weight your vehicle can tow. See your GMC dealer for additional details. <sup>5</sup>Maximum payload capacity includes weight of driver, passengers, optional equipment and cargo. <sup>6</sup>Capacities and weight ratings are dependent on model, engine, transmission and GVWR combinations. See your GMC dealer for details. <sup>7</sup>Cargo and load capacity limited by weight and distribution. <sup>8</sup>When properly equipped; includes weight of vehicle, passengers, cargo and equipment. <sup>9</sup>Long Box models 475 lbs.

## SIERRA HD SPECIFICATIONS

### ENGINES

	VORTEC 6.0L V-8 VVT (L96)	DURAMAX DIESEL 6.6L V-8 TURBO (LML)
FUEL TYPE	Gasoline (FlexFuel)	Diesel (B20 biodiesel capable)
CAPACITY	6.0 liters (364 cu. in.)	6.6 liters (402 cu. in.)
SAE NET HORSEPOWER @ RPM	360 @ 5400 (<10,000-lb GVWR) 322 @ 4400 (>10,000-lb GVWR)	397 @ 3000
SAE NET TORQUE @ RPM (LB-FT)	380 @ 4200	765 @ 1600
TRANSMISSIONS:	Electronically controlled 6-speed heavy-duty automatic transmission with overdrive, electronic engine grade braking and Tow/Haul mode	Electronically controlled Allison 1000 Series 6-speed automatic transmission with overdrive, electronic engine grade braking and Tow/Haul mode

### STANDARD TECHNICAL DATA

Series / Drive Type	All models: Power 4-wheel antilock braking system	
	2WD	4WD
BRAKES	14" dia. 4-wheel disc	14" dia. 4-wheel disc
STEERING	Power recirculating ball	Power recirculating ball
FUEL TANK CAPACITY (Approx gals.: Standard / Long Box)	36.0	36.0
ALTERNATOR (Amps)	125	125

### MAXIMUM GVWR<sup>1</sup> (GROSS VEHICLE WEIGHT RATING) VORTEC 6.0L V-8/DURAMAX DIESEL 6.6L V-8 TURBO

	REGULAR CAB	EXTENDED CAB	CREW CAB
<b>2500HD</b>			
Standard Box	- / -	9500/10,000	9500/10,000
Long Box	10,000/9900	9500/10,000	9500/10,000
<b>3500HD</b>			
SRW	10,700/11,400	11,000/11,600	11,000/11,600
DRW	13,400/13,025	13,025/13,025	13,025/13,025

SELECT RATINGS All capacities in lbs	MAXIMUM PAYLOAD <sup>3</sup>	MAXIMUM TRAILERING <sup>4</sup> BALL HITCH		MAXIMUM TRAILERING <sup>4</sup> FIFTH-WHEEL OR GOOSENECK	
		Vortec 6.0L V-8 / Duramax Diesel 6.6L V-8 Turbo		Vortec 6.0L V-8 / Duramax Diesel 6.6L V-8 Turbo	
<b>2500HD</b>					
Regular Cab Long Box	4212/3538	13,000/13,000	13,000/13,000	14,700/17,800	14,400/17,500
Extended Cab Standard Box	3473/3189	13,000/13,000	13,000/13,000	14,300/17,500	14,000/16,400
Extended Cab Long Box	3358/3275	13,000/13,000	13,000/13,000	14,200/17,400	13,900/15,700
Crew Cab Standard Box	3347/3066	13,000/13,000	13,000/13,000	14,200/17,400	13,900/15,800
Denali Crew Cab Standard Box	3193/2899	13,000/13,000	13,000/13,000	14,000/16,500	13,700/14,700
Crew Cab Long Box	3247/3305	13,000/13,000	13,000/13,000	14,100/16,700	13,800/14,700
<b>3500HD</b>					
Regular Cab SRW	4625/4609	13,000/-	13,000/13,000	14,500/-	14,200/17,400
DRW	7222/6876	14,100/-	13,800/16,000	14,200/-	13,800/23,100
Extended Cab SRW	4459/4455	13,000/13,000	13,000/13,000	14,000/17,300	13,700/16,900
DRW	6349/6068	13,600/16,500	13,400/18,000	13,700/22,800	13,400/22,600
Crew Cab SRW Standard Box	4187/4190	13,000/13,000	13,000/13,000	14,000/17,200	13,700/17,000
SRW Long Box	4308/4266	13,000/13,000	13,000/13,000	13,900/17,300	13,600/16,800
Denali SRW	4100/4078	13,000/13,000	13,000/13,000	13,800/17,100	13,600/16,800
DRW	6245/5914	13,500/16,500	13,200/18,000	13,500/22,800	13,200/22,500
Denali DRW	6114/5786	13,400/16,500	13,000/18,000	13,400/22,600	13,100/22,300

### FRONT SUSPENSIONS<sup>5</sup>

#### INDEPENDENT TORSION BAR-2500HD/3500HD

STANDARD FRONT AXLE CAPACITY	2WD	4WD
Regular Cab (lbs)	4400 / 4400	4400 / 4400
Extended Cab (lbs)	4400 / 4400	4400 / 4800
Crew Cab (lbs)	4400 / 4400	4800 / 4800

#### STANDARD FRONT SPRING

STANDARD FRONT SPRING CAPACITY	2WD	4WD
Regular Cab (lbs)	4400 / 4400	4400 / 4400
Extended Cab (lbs)	4400 / 4400	4800 / 4800
Crew Cab (lbs)	4400 / 4400	4800 / 4800

### REAR SUSPENSIONS<sup>5</sup>

#### SEMI-ELLIPTICAL MULTILEAF-2500HD/3500HD-SRW/3500HD-DRW

REAR AXLE CAPACITY	2WD
Regular Cab (lbs)	6200 / 7050 / 9825
Extended Cab (lbs)	6200 / 7050 / 9375
Crew Cab (lbs)	6200 / 7050 / 9375

#### REAR SPRING CAPACITY

REAR SPRING CAPACITY	2WD
Regular Cab (lbs)	6200 / 7050 / 9825
Extended Cab (lbs)	6200 / 7050 / 9375
Crew Cab (lbs)	6200 / 7050 / 9375

#### REAR AXLE CAPACITY

REAR AXLE CAPACITY	4WD
Regular Cab (lbs)	6200 / 7050 / 9825
Extended Cab (lbs)	6200 / 7050 / 9375
Crew Cab (lbs)	6200 / 7050 / 9375

#### REAR SPRING CAPACITY

REAR SPRING CAPACITY	4WD
Regular Cab (lbs)	6200 / 7050 / 9375
Extended Cab (lbs)	6200 / 7050 / 9375
Crew Cab (lbs)	6200 / 7050 / 9375

<sup>1</sup>When properly equipped; includes weight of vehicle, passengers, cargo and equipment. <sup>2</sup>Cargo and load capacity limited by weight and distribution. <sup>3</sup>Maximum payload capacity includes weight of driver, passengers, optional equipment and cargo. <sup>4</sup>Maximum trailer weight ratings are calculated assuming a base vehicle, except for any option(s) necessary to achieve the rating, plus driver. The weight of other optional equipment, passengers and cargo will reduce the maximum trailer weight your vehicle can tow. <sup>5</sup>Capacities and weight ratings are dependent on model, engine, transmission and GVWR combinations. See your GMC dealer for details.

# IMPORTANT WORDS

## COMMITMENT PLUS

From the owner orientation – and full tank of gas – you receive when you take possession of your Sierra to the **24-Hour Roadside Assistance, Courtesy Transportation** and **Travel Benefits**, Commitment Plus is a portfolio of owner privileges that lasts throughout your warranty. For expert product information, Roadside Assistance or other services, call 1-800-GMC-8782.

**TRAVEL BENEFITS AND ROADSIDE ASSISTANCE** Available around the clock: trip routing service, a program for reimbursement for trip interruption due to necessary warranty repairs, towing, flat tire change, jump-starts and more for 5 years or 100,000 miles (whichever comes first).

**COURTESY TRANSPORTATION** Available at participating dealers: shuttle service, reimbursement of certain public transportation or fuel expenses for overnight warranty repairs, and courtesy rental for overnight work repairs. See your dealer for details.

**GMC OWNER CENTER** A complimentary, one-stop resource to enhance your GMC ownership experience. It's easy to sign up. Just go to [gm.com/gmownercenter/gmc](http://gm.com/gmownercenter/gmc).

## ONSTAR



OnStar is a core asset of your Sierra. Benefiting from more than a decade of innovative development, it is both a highly advanced technology – fully integrated within the vehicle – and a warm human service. Standard on all Sierra models (except WT models) are 6 months of the OnStar Directions & Connections Plan, including the convenience of available Hands-Free Calling. It also includes Automatic Crash Response, Stolen Vehicle Assistance, link to Emergency Services, Roadside Assistance, Remote Door Unlock, OnStar Vehicle Diagnostics, Crisis Assist and Remote Horn and Lights. OnStar services require vehicle electrical system (including battery), wireless service and GPS satellite signals to be available and operating for features to function properly. OnStar acts as a link to existing emergency service providers. Visit [onstar.com](http://onstar.com) for coverage maps, details and system limitations. Services vary with conditions.

## HANDS-FREE CALLING

Available OnStar Hands-Free Calling capability is built into your Sierra. It's there when your cell phone is unavailable, its battery is low, you can't reach it easily or you left it at home or in the office. Your Hands-Free Calling system is the right choice whenever you need an easy way to make and receive calls – at the touch of the phone icon on the rearview mirror or the steering-wheel-mounted controls. Voice-activated dialing is convenient because you don't have to dial when you are at the wheel. And Hands-Free Calling is reliable because it's specially designed for better reception and fewer dropped calls in areas of limited cellular reception.

## ONSTAR TURN-BY-TURN NAVIGATION

Standard on all Sierra models (except WT models) are 6 months of the OnStar Directions & Connections Plan that adds innovative, easy-to-use Turn-by-Turn Navigation plus Information and Convenience Services and Driving Directions. With Turn-by-Turn Navigation, you simply tell the OnStar Advisor your intended destination, and directions will automatically be sent to your Sierra. If you drive off course, the system can reroute you to your intended destination. An automated voice then guides you turn-by-turn until you arrive at your destination. Turn-by-Turn Navigation is further enhanced with eNAV, allowing you to send MapQuest™ directions directly to your vehicle. No need to print out directions; just call them up with simple voice commands.

## SIRIUSXM SATELLITE RADIO



SiriusXM Satellite Radio<sup>3</sup> is standard on all Sierra models (except WT). It includes 3 trial months of service. SiriusXM Satellite Radio makes your drive come alive with commercial-free music channels from virtually every genre, artist-dedicated channels, live performances and more. Tune in to live play-by-play from the biggest sports, exclusive entertainment from top personalities, compelling talk, hilarious comedy, world-class news, local traffic and weather and family-friendly programming. Welcome to the world of satellite radio. Visit [siriusxm.com](http://siriusxm.com) for details.

## GMC CERTIFIED SERVICE



To help your Sierra live up to its performance promise, GMC Certified Service – found exclusively at your GMC dealer – is there. With all the engineering excellence in Sierra, GM-trained technicians have the expertise to care for all of it.

**A NOTE ON CHILD SAFETY** Always use safety belts and the correct child restraint for your child's age and size, even with air bags. Even in vehicles equipped with the Passenger Sensing System, children are safer when properly secured in a rear seat in the appropriate infant, child or booster seat. Never place a rear-facing infant restraint in the front seat of any vehicle equipped with an active frontal air bag. See the Owner's Manual and child safety seat instructions for more safety information.

## ADDITIONAL NOTES

**TRAILERING AND OFF-ROAD INFORMATION** Please carefully review the Owner's Manual for important safety information about trailering or off-road driving in your vehicle.

**IMPORTANT WORDS ABOUT THIS CATALOG** We have tried to make this catalog comprehensive and factual. We reserve the right, however, to make changes at any time, without notice, in prices, colors, materials, equipment, specifications, models and availability. Specifications, dimensions, measurements, ratings and other numbers in this catalog and other printed materials provided at the dealership or affixed to vehicles are approximates based upon design and engineering drawings and prototypes and laboratory tests. Your vehicle may differ due to variations in manufacture and equipment. Since some information may have been updated since the time of printing, please check with your GMC dealer for complete details. GMC reserves the right to lengthen or shorten the model year for any product for any reason, or to start and end model years at different times.

**FLEET ORDERS** Some standard content may be deleted with fleet orders. See dealer for details.

**ENGINES** GMC products are equipped with engines produced by GM Powertrain or other suppliers to GM worldwide. The engines in GMC products may also be used in other GM makes and models.

**GMC.COM** See more of Sierra on our Web site: [gmc.com/sierra](http://gmc.com/sierra). More photos and information; hot links to related subjects; convenient dealer locator; pricing guide, spec out your own vehicle. Or call 1-800-GMC-8782.

**AN IMPORTANT NOTE ABOUT ALTERATIONS AND WARRANTIES** Installations or alterations to the original equipment vehicle (or chassis) as distributed by General Motors are not covered by the General Motors New-Vehicle Limited Warranty. The special body company, assembler, equipment installer or upfitter is solely responsible for warranties on the body or equipment and any alterations (or any effect of the alterations) to any of the parts, components, systems or assemblies installed by GM. General Motors is not responsible for the safety or quality of design features, materials or workmanship of any alterations by such suppliers.

**NEW-VEHICLE LIMITED WARRANTY** All GMC light-duty vehicles come with a fully transferable, no-deductible 5-year/100,000-mile (whichever comes first) Powertrain Limited Warranty. GM vehicles registered in the U.S.A. are also covered for 3 years or 36,000 miles (whichever comes first). Coverage includes tires and towing to your nearest GMC dealership. Repairs will be made to correct any vehicle defect and most warranty repairs will be made at no charge. In addition, rust-through corrosion will be covered for 6 years or 100,000 miles (whichever comes first). See dealer for details.

**ASSEMBLY** GMC vehicles and their components are assembled or produced by different operating units of General Motors, its subsidiaries or suppliers to GM worldwide. We sometimes find it necessary to produce GMC vehicles with different or differently sourced components than originally scheduled. Since some options may be unavailable when your vehicle is assembled, we suggest that you verify that your vehicle includes the equipment you ordered or, if there are changes, that they are acceptable to you.

**GMMOBILITY.COM** (1-800-323-9935) GM Mobility offers financial assistance for eligible adaptive equipment to make automotive travel easier for persons with disabilities or special transportation needs. To learn more about special GM Mobility offers, visit [gmmobility.com](http://gmmobility.com).

**GMCARDMEMBERSERVICES.COM** Did you know about the family of reward credit cards that can help you get a great deal on a new GM car, light-duty truck, SUV or crossover? With a GM reward card, you accrue earnings on every credit card purchase to use toward the purchase or lease of an eligible new GM vehicle. With three cards to choose from, you're sure to find one that suits you.

<sup>1</sup>If you subscribe after your trial period, *subscriptions are continuous until you call SiriusXM to cancel*. See SiriusXM Customer Agreement for complete terms at [siriusxm.com](http://siriusxm.com). Other fees and taxes will apply. All fees and programming subject to change. For more information about NavTraffic, visit [siriusxm.com/navtraffic](http://siriusxm.com/navtraffic). For more information about Travel Link, visit [siriusxm.com/travellink](http://siriusxm.com/travellink). XM satellite service is available only to those in the 48 contiguous USA and DC.

©2012 General Motors. All rights reserved. GM, the GM logo, GMC, the slogans, emblems, vehicle model names, vehicle body designs and other marks appearing in this catalog are the trademarks and/or service marks of General Motors, its subsidiaries, affiliates or licensors. Bose, Centerpoint, AudioPilot and SurroundStage are registered trademarks of the Bose Corporation. iPod and iPhone are registered trademarks of Apple, Inc. Facebook is a registered trademark of Facebook, Inc. Twitter is a registered trademark of Twitter, Inc. YouTube is a registered trademark of Google, Inc. SiriusXM is a registered trademark of SiriusXM Satellite Radio.



VISIT US AT [GMC.COM](http://GMC.COM)



[FACEBOOK.COM/GMC](https://FACEBOOK.COM/GMC)



[TWITTER.COM/THISISGMC](https://TWITTER.COM/THISISGMC)



[YOUTUBE.COM/GMC](https://YOUTUBE.COM/GMC)

136MCSRARC-25