



2014 OUTLANDER



THE ONLY SOURCE OF KNOWLEDGE IS EXPERIENCE.

— *Albert Eiwn*



**MITSUBISHI
MOTORS**

THE WISDOM OF LESS

In an industry where every manufacturer seems to be offering you more of the same, we'd like to extend to you an entirely different offer: Less. Meet the all-new 2014 Mitsubishi Outlander. Its curb weight is a full 220 pounds less than last year's model. That translates into more fuel efficiency. And with its enhanced aerodynamic design, it creates less wind drag, making it even more efficient.

Outlander's cleaner-running MIVEC engine has less impact on the environment. Which is far more responsible. And with its newly redesigned and relocated insulation materials, you'll experience less road noise and vibration. Its convenient power tailgate means there's less effort required to load gear. Even starting the engine requires less work with its One-touch Start/Stop engine switch. But most importantly, driving the all-new Outlander means less worry. In addition to offering one of the best warranties in the business, the Outlander is equipped with some of the most advanced safety systems in its class. Now you have one less reason to drive anything else.

LESS OF THE SAME

At Mitsubishi, we're proud to be a part of the automotive tradition in America. Since the day we sold our first U.S. vehicle back in 1982, we've been committed to building vehicles that aren't the typical imitations so common these days, but that offer a unique blend of spirited performance, head-turning style and genuine durability. Cars that are more than merely a means of transportation, but a moving expression of the driver within.

And the qualities that we strive for, we stand behind. In fact, many of our vehicles are backed with a 10-year/100,000-mile Limited Powertrain Warranty, a 5-year/60,000-mile fully transferable New Vehicle Limited Warranty, a 7-year/100,000-mile Anti-Corrosion/Perforation Limited Warranty and 5-year/Unlimited Mile Roadside Assistance. It's one of the most comprehensive suites of warranties in the industry. For, like our cars, we intend to serve you well for many years to come.



SECTIONS

1. DESIGN

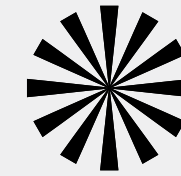

P. 05-10

2. ECOLOGY

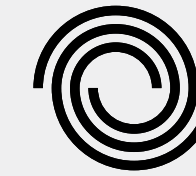

P. 13-18

3. SAFETY

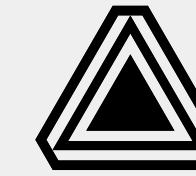

P. 21-26

4. ACCOMMODATION

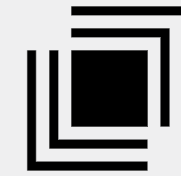

P. 29-34

5. HERITAGE

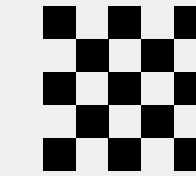

P. 37-40

6. SPECIFICATIONS



P. 43-50



DESIGN

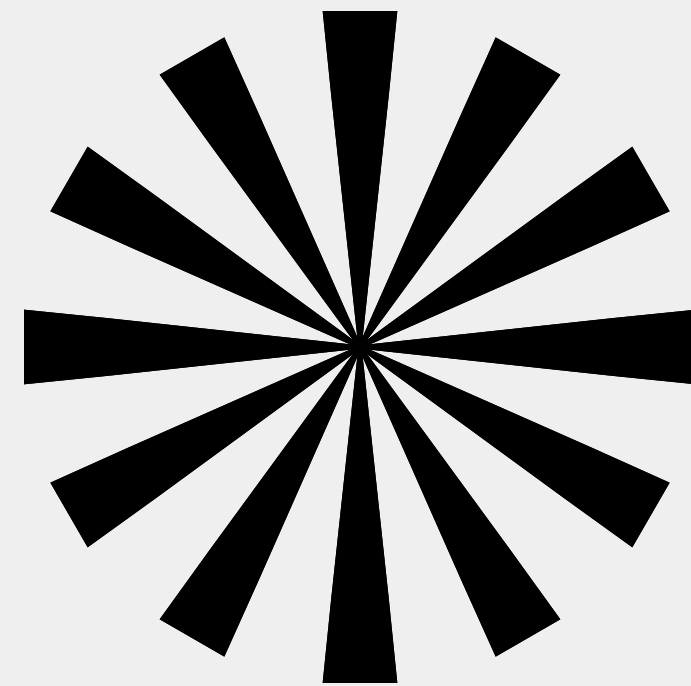

PASSION MEETS PRECISION

When you care about quality, it shows. And the progressive exterior of the all-new Outlander exemplifies that fact. With sweeping, clean lines and subtly sculpted sides, the sleek skin of the Outlander has been designed to be both eye catching and wind slipping.

To help achieve the Outlander's unique balance of aesthetics and aerodynamics, our engineers and designers conducted an exhaustive series of wind tunnel tests and meticulous computerized analysis. The result is not only a sleek and seductive outward appearance, but also a dramatic reduction in wind resistance.



EXTERIOR SENSIBILITIES

The task of achieving aerodynamic efficiency is a concert of surface refinements. Note the Outlander's roofline is gently tapered to the rear, while the roof itself employs shallow channels that help dictate airflow. At the roof's rear edge — the wind's departure point — a spoiler helps reduce turbulence behind the vehicle. Wind resistance, however, is as much a factor beneath the vehicle as above it. That's why we engineered Outlander's undercarriage for smooth airflow as well. Together, these subtle refinements in shape help achieve a low coefficient of drag. And more efficient airflow means better fuel economy.

FINDING BEAUTY WITHIN

Our quest for efficiency was not limited to Outlander's exterior. The cabin, too, is a study in simplicity. From the sweeping dashboard to the scalloped door panels, the driver-centric cockpit conveys a sense of order and ergonomic attention. A hi-res meter cluster is crisply detailed and readily informative. Even the push-button ignition was designed for simplicity — both in appearance and in operation. Let the drive begin.







P. 12

Outlander ES in Diamond White

ECOLOGY

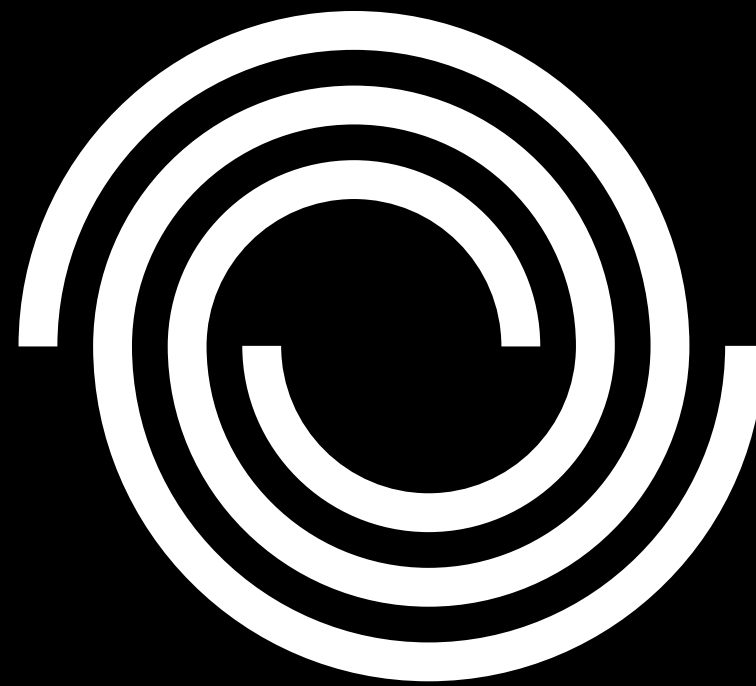

P. 13-18

New 2.4L MIVEC Engine
3.0L V-6 MIVEC Engine
ECO Drive Support System

LESS IS MORE

When the right elements are subtracted from an equation, less is, indeed, more. Like less fuel consumption, for example. The 2014 Outlander is the most fuel-efficient standard 7-passenger CUV on the market today.¹

First, we engineered a new lightweight body, making Outlander 220 pounds lighter than last generation. We also streamlined the body and designed a new aerodynamic front fascia, creating 7% less wind resistance. And because the streamlined exterior helps improve fuel economy, it also helps reduce CO2 emissions. We even enhanced efficiency by reducing the energy consumption of the interior heating and cooling system.





NEW 2.4L MIVEC ENGINE

Outlander's new 2.4-liter 166-horsepower aluminum-block 4-cylinder engine features a newly developed continuously variable valve lift system. This efficient engine employs a single mechanism to vary the valve lift and timing for optimum engine "breathing."

The powerful MIVEC engine is coupled with a Continuously Variable Transmission (CVT). The CVT, along with a new Acceleration Control feature, offers a smooth "shift" feel, more responsive acceleration and improved fuel economy.

3.0L V-6 MIVEC ENGINE

The sporty Outlander GT boasts a 24-valve 3.0-liter V-6 MIVEC engine that produces a full 224 horsepower at 6,250 rpm and 215 lb.-ft. of torque at 3,750 rpm. This powerful engine utilizes low viscosity engine oil and iridium spark plugs to help maximize fuel efficiency. Plus, a refined 6-speed automatic transmission helps deliver improved torque and fuel efficiency.

ECO DRIVE SUPPORT SYSTEM

When the ECO Mode is engaged, the system helps you drive in a more environmentally friendly fashion. By slightly reducing engine power on initial acceleration, Outlander employs energy saving measures throughout the vehicle, including the engine and air conditioning system. Plus, on Outlander models equipped with Super All-Wheel Control (S-AWC), the ECO Mode allows the vehicle to function in 2WD until sensors determine that 4WD is necessary. The result is not only better fuel economy, but also lower emissions.



ECOLOGY

LESS IS MORE



SAFETY



ENGINEERING LESS WORRY

When we set out to create the all-new Outlander, accounting for your safety was job one. That's why it's equipped with some of the most advanced active safety and passive safety features in its class. We believe you can't be over-prepared for the unexpected.

Outlander is loaded with technology to help keep you out of harm's way. Along with seven standard airbags, its many advanced features include Active Stability Control (ASC) with Traction Control Logic (TCL), enhanced pedestrian protection with redesigned hood and front fenders, a Tire Pressure Monitoring System (TPMS), and Mitsubishi's RISE (Reinforced Impact Safety Evolution) energy-absorbing technology.

RISE [REINFORCED IMPACT SAFETY EVOLUTION] BODY

RISE engineering helps provide occupant protection in the event of a collision. RISE combines energy-absorbing front and rear structures with a rigid occupant cell. Along with reinforcing bars in the doors and energy-absorbing materials in the side pillars, the 2014 Outlander's RISE body features a 6% increase in the total use of high-tensile strength steel that reduces weight while keeping high collision safety.

SEVEN STANDARD AIRBAGS²

Outlander's standard Supplemental Restraint System (SRS) features seven airbags, including dual-stage front airbags with a driver's seat position sensor, driver and passenger seat-mounted side-impact airbags, side curtain airbags, and a driver's knee airbag.





SUPER-WIDE RANGE HID HEADLIGHTS

Talk about bright ideas, the Outlander GT is equipped with Super-wide High Intensity Discharge Headlamps (S-HID). Using xenon gas, they project a beam that's 20% brighter than normal lights. What's more, the light they emit more closely mimics that of the sun, making for better definition and less eye fatigue.

ADAPTIVE CRUISE CONTROL³

The available adaptive Cruise Control works like standard cruise control — only better. It uses a 77-GHz radar unit to detect a car ahead, and maintains a preset distance between you and that car. If the car ahead is going slower than your set speed, the system will slow your car to the same speed, maintaining a driver-selectable following distance. If the car ahead speeds up, your Outlander will match its speed (up to your set speed). If the car moves out of your lane or accelerates beyond your set speed, Outlander will resume your set speed.

LANE DEPARTURE WARNING⁴

Most traffic accidents are due to driver error or simple inattention. Outlander's available Lane Departure Warning system can help reduce the potential dangers associated with drifting out of lanes. A camera mounted on the inside front windshield monitors the lane position in front of the vehicle. If the vehicle is about to depart from its established lane, the system cautions the driver with a display and alarm.

FORWARD COLLISION MITIGATION⁵

The radar unit employed by the Adaptive Cruise Control is also used to help reduce the severity of a frontal collision. If the available Forward Collision Mitigation system determines that a frontal collision is imminent, it warns the driver with audible and visual signals, and automatically applies emergency braking to avoid collision or reduce impact.



SAFETY

ENGINEERING LESS WORRY





ACCOMMODATION

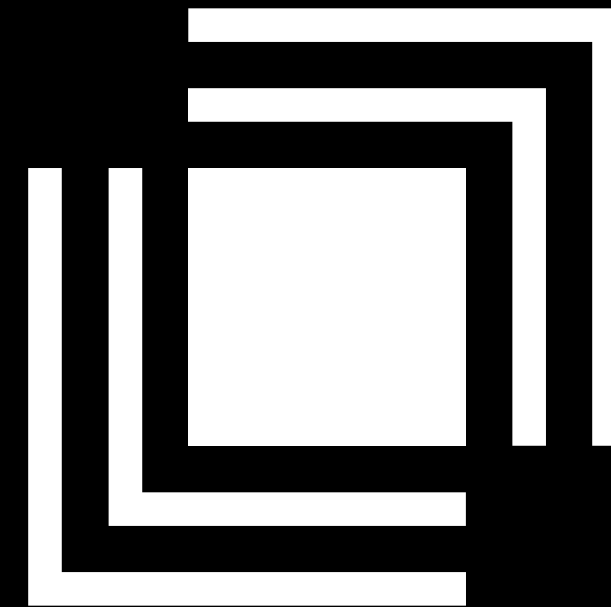

THE ELEMENTS OF COMFORT

Sometimes the best way to increase comfort is by reducing unpleasant stimuli. To help cut down on noise and vibration in Outlander's 7-passenger cabin, we designed a variety of subtle ways to improve insulation and increase overall body rigidity.

To help enrich occupant comfort, we precision-sculpted seatbacks and door panels, creating more interior space. We made touch points less rigid by using high quality materials, such as those found on the soft-touch instrument panel. Distinctive, upscale design cues abound: Rich woodgrain trim. A glossy piano black center panel. Together, these small subtractions effectively enhance the overall driving experience.



FAST-KEY PASSIVE ENTRY SYSTEM

Outlander's FAST-Key (Free-hand Advanced Security Transmitter) system makes vehicle entry easy. Lock or unlock the doors by simply pressing the button on either front door or the trunk switch. You can even start the engine with the keys tucked away in a pocket or purse.

TILT AND TELESCOPING STEERING WHEEL

Those who share their Outlander with other drivers will appreciate the all-new tilt and telescoping steering wheel. It makes finding that perfect driving position a quick and easy operation.

FUSE HANDS-FREE LINK SYSTEM® WITH USB PORT

Featuring Bluetooth® 2.0 technology and advanced speech recognition, FUSE is the Outlander's mobile command center.⁶ It links seamlessly with up to seven Bluetooth-enabled phones, your iPod® other MP3 players and USB devices, allowing you to place a call from your contact list or play your entire music collection on the audio system.⁷ Simply press a button and speak a voice command.





DUAL-ZONE AUTOMATIC CLIMATE CONTROL

The 2014 Outlander gives front-seat occupants customized comfort. The front vents are divided into separate systems with separate temperature controls, so the driver and front passenger can each control the environment on their side of the vehicle.

POWER LIFTGATE

Adding to Outlander's accommodating nature is an available automatic power liftgate. Conveniently open or close the rear gate with the key fob, with buttons on the gate itself, or with buttons on the dashboard.

MITSUBISHI MULTI-COMMUNICATION SYSTEM (MMCS)

Boasting a 7 in. high-definition touch-panel display, the intuitive Mitsubishi Multi-Communication System (MMCS) offers a host of advanced features, including 3-D mapping, expanded Point of Interest (POI) information and road speed limit display, ECO routing and subscription-free Real-time Traffic with Diamond Lane Guidance.

6.1" TOUCH PANEL DISPLAY AUDIO SYSTEM

Outlander's available Rockford Fosgate® 710-watt audio system powers 8 premium speakers and a 10 in. dual-voice subwoofer.⁸ The system incorporates an advanced Digital Signal Processor (DSP) and offers the listener Punch Control® of the subwoofer, sound field control of the image and staging of the system, as well as the latest Neural Surround Sound technology from DTS®. The system is loaded with features like SiriusXM® Satellite Radio and HD Radio®, along with state-of-the-art technologies, such as Dolby® Volume, PremiDIA HD and PremiDIA HD Wide for the best audio performance on the road.⁹

FOLD-FLAT VERSATILITY

The third-row seats are split 50/50 and can be easily stowed with the pull of a single fold-and-store strap, or quickly returned to their upright position by simply raising the seatback. Additionally, the 60/40 split and fold second-row seats give you numerous passenger and payload configurations to choose from.



ACCOMMODATION

P. 35



THE ELEMENTS OF COMFORT



HERITAGE

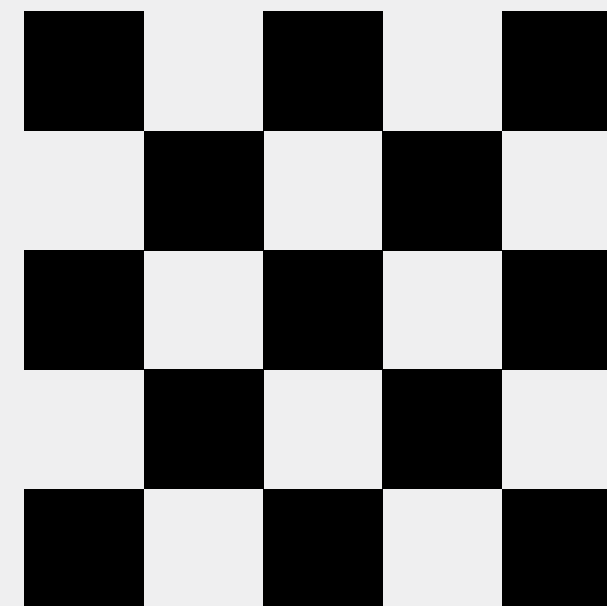

A TRADITION OF TRACTION

With a long history of all-wheel drive systems, our road-handling credentials are legendary. In fact, Outlander's available Super All-Wheel Control (S-AWC) is the most advanced vehicle dynamics control system in the segment.

S-AWC is an integration of several advanced technologies that together take full advantage of the engine's power. The Active Front Differential (AFD) distributes engine power between left and right on the front axle. Active Stability Control (ASC) helps keep the vehicle on its intended path when cornering, and the Anti-lock Braking System (ABS) along with Electronic Brakeforce Distribution (EBD) improves control and stability under hard braking. With the push of a button, the driver can select from four S-AWC modes to achieve maximum traction regardless of surface conditions. Those modes include Normal Mode, Snow Mode, Lock Mode and a new AWC ECO Mode.



NORMAL MODE

Normal Mode is employed to help maximize fuel efficiency and driving comfort on regular asphalt roads, wet or dry.

SNOW MODE

Snow Mode is engaged on ice and snow or whenever the road surface conditions are extremely slick.

LOCK MODE

This mode locks in full Super All-Wheel Control to help maximize traction on unpredictable road surfaces.

AWC ECO MODE

This mode helps maximize economy by making fuel efficient 2-wheel drive the priority, engaging the 4-wheel drive only if the system detects that the wheels are beginning to slip.

HERITAGE

A TRADITION OF TRACTION





ES FWD

ENGINE	
Drivetrain	Front-Wheel Drive (FWD)
Type	2.4L MIVEC SOHC 16-valve Inline 4-cylinder
Engine code	4J12
Materials	Aluminum block/aluminum cylinder heads
Bore x stroke	88.0 mm x 97.0 mm
Compression ratio	10.5
Displacement	2.4L/2,360 cc
Horsepower	166 @ 6,000 rpm
Torque	162 lb-ft @ 4,200 rpm
Redline RPM	6,500
Emissions	LEV-II-ULEV
Engine oil	0W-20
Recommend fuel	Regular unleaded

TRANSMISSION	
Continously Variable Transmission (CVT)	STD
6-speed electronic automatic (6AT)	–

SUSPENSION	
Front	MacPherson strut with stabilizer bar
Rear	Multi-link with stabilizer bar

STEERING	
Type	Electric Power Steering
Turns, lock to lock	3.3
Turning radius (curb to curb)	34.8 ft.

BRAKES/TIRES/WHEELS	
Brakes:	
• Front	Ventilated single piston disc, 11.6 in. (294 mm)
• Rear	Solid single piston disc, 11.9 in. (302 mm)
• ABS	4-wheel, 4-channel, 4-sensor with Electronic Brake-force Distribution (EBD) and Brake Assist
Wheels	16 x 6 1/2 steel with cover
Tires	P215/70 R16

CAPACITIES	
Passenger seating	7
Fuel	16.6 gallons
Oil	4.5 quarts (4.3 liters)
Tow capacity (MAX)	1,500 lbs.
Trailer tongue weight (MAX)	150 lbs.

WEIGHTS	
Curb weight	3,274 lbs.
GVWR	4,795 lbs.
Weight distribution	57/43 (%)

FUEL ECONOMY ¹⁰	
City	25/mpg
Highway	31/mpg
Combined	27/mpg

SE FWD

ENGINE	
Drivetrain	Front-Wheel Drive (FWD)
Type	2.4L MIVEC SOHC 16-valve Inline 4-cylinder
Engine code	4J12
Materials	Aluminum block/aluminum cylinder heads
Bore x stroke	88.0 mm x 97.0 mm
Compression ratio	10.5
Displacement	2.4L/2,360 cc
Horsepower	166 @ 6,000 rpm
Torque	162 lb-ft @ 4,200 rpm
Redline RPM	6,500
Emissions	LEV-II-ULEV
Engine oil	0W-20
Recommend fuel	Regular unleaded

TRANSMISSION	
Continously Variable Transmission (CVT)	STD
6-speed electronic automatic (6AT)	–

SUSPENSION	
Front	MacPherson strut with stabilizer bar
Rear	Multi-link with stabilizer bar

STEERING	
Type	Electric Power Steering
Turns, lock to lock	3.3
Turning radius (curb to curb)	34.8 ft.

BRAKES/TIRES/WHEELS	
Brakes:	
• Front	Ventilated single piston disc, 11.6 in. (294 mm)
• Rear	Solid single piston disc, 11.9 in. (302 mm)
• ABS	4-wheel, 4-channel, 4-sensor with Electronic Brake-force Distribution (EBD) and Brake Assist
Wheels	18 x 7.0 aluminum alloy
Tires	P225/55 R18

CAPACITIES	
Passenger seating	7
Fuel	16.6 gallons
Oil	4.5 quarts (4.3 liters)
Tow capacity (MAX)	1,500 lbs.
Trailer tongue weight (MAX)	150 lbs.

WEIGHTS	
Curb weight	3,296 lbs.
GVWR	4,795 lbs.
Weight distribution	57/43 (%)

FUEL ECONOMY ¹⁰	
City	25/mpg
Highway	31/mpg
Combined	27/mpg

SE S-AWC

ENGINE	
Drivetrain	Super All-Wheel Control (S-AWC)
Type	2.4L MIVEC SOHC 16-valve Inline 4-cylinder
Engine code	4J12
Materials	Aluminum block/aluminum cylinder heads
Bore x stroke	88.0 mm x 97.0 mm
Compression ratio	10.5
Displacement	2.4L/2,360 cc
Horsepower	166 @ 6,000 rpm
Torque	162 lb-ft @ 4,200 rpm
Redline RPM	6,500
Emissions	LEV-II-ULEV
Engine oil	0W-20
Recommend fuel	Regular unleaded

TRANSMISSION	
Continously Variable Transmission (CVT)	STD
6-speed electronic automatic (6AT)	–

SUSPENSION	
Front	MacPherson strut with stabilizer bar
Rear	Multi-link with stabilizer bar

STEERING	
Type	Electric Power Steering
Turns, lock to lock	3.3
Turning radius (curb to curb)	34.8 ft.

BRAKES/TIRES/WHEELS	
Brakes:	
• Front	Ventilated single piston disc, 11.6 in. (294 mm)
• Rear	Solid single piston disc, 11.9 in. (302 mm)
• ABS	4-wheel, 4-channel, 4-sensor with Electronic Brake-force Distribution (EBD) and Brake Assist
Wheels	18 x 7.0 aluminum alloy
Tires	P225/55 R18

CAPACITIES	
Passenger seating	7
Fuel	15.8 gallons
Oil	4.5 quarts (4.3 liters)
Tow capacity (MAX)	1,500 lbs.
Trailer tongue weight (MAX)	150 lbs.

WEIGHTS	
Curb weight	3,461 lbs.
GVWR	4,795 lbs.
Weight distribution	56/44 (%)

FUEL ECONOMY ¹⁰	
City	24/mpg
Highway	29/mpg
Combined	26/mpg

GT S-AWC

ENGINE	
Drivetrain	Super All-Wheel Control (S-AWC)
Type	3.0L MIVEC SOHC 24-valve V6
Engine code	6B31
Materials	Aluminum block/aluminum cylinder heads
Bore x stroke	87.6 mm x 82.9 mm
Compression ratio	10.5
Displacement	3.0L/2,998 cc
Horsepower	224 @ 6,250 rpm
Torque	215 lb-ft @ 3,750 rpm
Redline RPM	6,500
Emissions	LEV-II-ULEV
Engine oil	0W-20
Recommend fuel	Premium unleaded

TRANSMISSION	
Continously Variable Transmission (CVT)	–
6-speed electronic automatic (6AT)	STD

SUSPENSION	
Front	MacPherson strut with stabilizer bar
Rear	Multi-link with stabilizer bar

STEERING	
Type	Electric Power Steering
Turns, lock to lock	3.3
Turning radius (curb to curb)	34.8 ft.

BRAKES/TIRES/WHEELS	
Brakes:	
• Front	Ventilated single piston disc, 11.6 in. (294 mm)
• Rear	Solid single piston disc, 11.9 in. (302 mm)
• ABS	4-wheel, 4-channel, 4-sensor with Electronic Brake-force Distribution (EBD) and Brake Assist
Wheels	18 x 7.0 aluminum alloy
Tires	P225/55 R18

CAPACITIES	
Passenger seating	7
Fuel	15.8 gallons
Oil	4.2 quarts (4.0 liters)
Tow capacity (MAX)	3,500 lbs.
Trailer tongue weight (MAX)	350 lbs.

WEIGHTS	
Curb Weight	3,571 lbs.
GVWR	5,005 lbs.
Weight distribution	57/43 (%)

FUEL ECONOMY ¹⁰	
City	20/mpg
Highway	28/mpg
Combined	23/mpg

see www.fueleconomy.gov for EPA estimates. Your mileage will vary.

FEATURES AND OPTIONS

MECHANICAL FEATURES	ES FWD	SE FWD	SE S-AWC	GT S-AWC
Active front differential (S-AWC only)	–	–	STD	STD
Sportronic® steering wheel paddle shifters	–	–	–	STD
EXTERIOR FEATURES				
Super-wide High Intensity Discharge (HID) headlights	–	–	–	STD
Halogen headlights	STD	STD	STD	–
Auto-on/off headlights	–	OPT	OPT	STD
Auto-off headlights	STD	STD	STD	–
Fog lights	–	STD	STD	STD
Side-view mirror-mounted LED turn indicators	–	STD	STD	STD
Rear combination tail lights	STD	STD	STD	STD
Color-keyed front bumper	STD	STD	STD	STD
Color-keyed rear bumper	STD	STD	STD	STD
Color-keyed side-view mirrors	–	STD	STD	STD
Color-keyed outer door handles	STD	STD	STD	STD
Roof carrier plug-in accommodation	STD	STD	STD	STD
Chrome beltline molding	–	–	–	–
Front grille with chrome accents	STD	STD	STD	STD
V6 badge/GT Badge	–	–	–	–
S-AWC decal	–	–	STD	STD
Power glass sunroof	–	OPT	OPT	OPT
Heated side-view mirrors	STD	STD	STD	STD
Front windshield speed-sensitive variable intermittent wipers	STD	STD	STD	STD
Rear window intermittent wiper/ washer with defroster and timer	STD	STD	STD	STD
Rain-sensing windshield wipers	–	OPT	OPT	STD
Rear privacy glass	STD	STD	STD	STD
Aero wiper blades	STD	STD	STD	STD
18 in. alloy wheels	–	STD	STD	STD
16 in. steel wheels with full wheel covers	STD	–	–	–
P225/55R18 tires	–	STD	STD	STD
P215/70R16 tires	STD	–	–	–
INTERIOR FEATURES				
Full-color LCD multi-information display	–	STD	STD	STD
Monochromatic multi-information display	STD	–	–	–
High-contrast meter gauge cluster	–	STD	STD	STD
Instrument panel illuminated Hazard and ECO switches	STD	STD	STD	STD
Dual-visor vanity mirrors with illumination	STD	STD	STD	STD
Front map lights	STD	STD	STD	STD
Center dome light	STD	STD	STD	STD
Rear cargo area light	STD	STD	STD	STD
7-passenger seating	STD	STD	STD	STD
Leather seating surfaces	–	OPT	OPT	OPT
Deluxe fabric seating surfaces	STD	STD	STD	STD
Heated driver and front passenger seats	–	STD	STD	STD
8-way power adjustable driver's seat with seat back pocket	–	OPT	OPT	OPT
6-way adjustable driver's seat	STD	STD	STD	STD
4-way adjustable front passenger seat	STD	STD	STD	STD
Front passenger seat back pocket	STD	STD	STD	STD
60/40 split fold-down rear seats with independent slide and reclining adjustments (2nd row)	STD	STD	STD	STD
50/50 3rd-row flat fold-down feature	STD	STD	STD	STD
Rear seat (2nd row) adjustable head restraints (x3)	STD	STD	STD	STD
3rd-row seat head restraints (x2)	STD	STD	STD	STD
Front dual-zone climate control	–	STD	STD	STD

INTERIOR FEATURES (Cont.)	ES FWD	SE FWD	SE S-AWC	GT S-AWC
Automatic climate control	STD	STD	STD	STD
Leather-wrapped steering wheel and shift knob	–	STD	STD	STD
Tilt/telescoping steering wheel	STD	STD	STD	STD
Gloss black shifter panel with silver accent	–	STD	STD	STD
Leather-wrapped door armrest and trim panel insert	–	OPT	OPT	OPT
Fabric-wrapped door armrest and trim panel insert	STD	STD	STD	STD
Wood-grain appearance trim panels	–	OPT	OPT	STD
Silver painted trim panels	STD	STD	STD	–
Soft-touch upper instrument panel and door trim	STD	STD	STD	STD
Door scuff plate (front and rear)	STD	STD	STD	STD
Chrome-plated inner door handle	STD	STD	STD	STD
Floor mats	STD	STD	STD	STD
Remote hood and fuel door release lever	STD	STD	STD	STD
CONVENIENCE FEATURES				
MMCS Navigation system with 7 in. high definition touch panel, voice command, 3D mapping, point-of-interest information, real-time traffic, (replaces std. audio system head unit) and Mapcare® with two complimentary map updates	–	OPT	OPT	OPT
710-watt Rockford-Fosgate® premium sound system with 9 speakers including 10 in. dual-voice coil subwoofer with Punch Control®, DTS® Neural Surround, PremiDIA-WIDE® surround, and Dolby® Volume	–	–	–	–
6.1 in. touch panel display audio system (replaces std. audio system head unit)	–	STD	STD	STD
140-watt AM/FM/CD/MP3 audio system with 6 speakers	STD	STD	STD	STD
SiriusXM® Satellite Radio with 3-mo. subscription ⁹	–	OPT	OPT	STD
Digital HD Radio®	–	STD	STD	STD
FUSE Hands-free Link System® with Bluetooth® technology, USB port, and steering wheel controls	–	STD	STD	STD
Voice-activated Bluetooth® hands-free phone system	ACC	STD	STD	STD
Multi-information display (trip meter and odometer, outside temperature, average fuel consumption and driving distance, drive mode indicator, transmission position indicator, water temperature warning light, low fuel warning)	STD	STD	STD	STD
Rearview camera system	–	STD	STD	STD
Steering wheel-mounted cruise control and audio controls	STD	STD	STD	STD
Power remote liftgate	–	OPT	OPT	OPT
FAST-Key passive entry system with panic alarm feature	–	STD	STD	STD
Remote keyless entry with panic feature	STD	–	–	–
One-touch Start/Stop (OSS) engine switch	–	STD	STD	STD
ECO Mode switch	STD	STD	STD	STD
Cruise control	STD	STD	STD	STD
Power door locks and side-view mirrors	STD	STD	STD	STD
Power windows with driver's side auto up/down feature	STD	STD	STD	STD
12-volt accessory outlets (x2)	STD	STD	STD	STD
Floor center console box with armrest and cup holders (x2)	STD	STD	STD	STD
Instrument panel lower-center storage	STD	STD	STD	STD
Door trim pocket with bottle holder (x4)	STD	STD	STD	STD
Rear seat center armrest with cupholders	STD	STD	STD	STD
3rd-row cupholder and storage space	STD	STD	STD	STD
Underfloor cargo area storage	STD	STD	STD	STD
Cargo tie-down utility hooks (x4)	STD	STD	STD	STD
Retractable assist grips (x4)	STD	STD	STD	STD
Coat hangers (x1) at rear assist grip	STD	STD	STD	STD

SAFETY AND SECURITY	ES FWD	SE FWD	SE S-AWC	GT S-AWC
Adaptive Cruise Control (ACC) system ³	–	OPT	OPT	OPT
Forward Collision Mitigation (FCM) system ⁵	–	OPT	OPT	OPT
Lane Departure Warning (LDW) system ⁴	–	OPT	OPT	OPT
Hill Start Assist (HSA)	STD	STD	STD	STD
Anti-lock Braking System (ABS) with Electronic Brakeforce Distribution (EBD) and brake assist	STD	STD	STD	STD
Active Stability Control (ASC)	STD	STD	STD	STD
Traction Control Logic (TCL)	STD	STD	STD	STD
Tire Pressure Monitoring System (TPMS)	STD	STD	STD	STD
Front and rear side impact curtain airbags ²	STD	STD	STD	STD
(1st and 2nd-row occupants) with rollover protection	–	–	–	–
Front seat-mounted side airbags ²	STD	STD	STD	STD
Driver's knee airbag ²	STD	STD	STD	STD
Advanced dual-stage front airbags (SRS) with driver seat position sensor ²	STD	STD	STD	STD
Head impact protection roof and pillar trim	STD	STD	STD	STD
Three-point seatbelts and head restraints for all seating positions	STD	STD	STD	STD
Height adjustable front shoulder belts with pretensioner	STD	STD	STD	STD
LATCH child-restraint system	STD	STD	STD	STD
Child safety rear door locks	STD	STD	STD	STD
Anti-theft security alarm system	STD	STD	STD	STD
Anti-theft engine immobilizer	STD	STD	STD	STD
RISE body construction	STD	STD	STD	STD
Crumple zones for pedestrian protection	STD	STD	STD	STD

FACTORY PACKAGES

- SE Premium Package:** Optional for SE FWD and SE S-AWC
- 710-watt Rockford-Fosgate® premium sound system with 9 speakers including 10 in. dual-voice coil subwoofer with Punch Control®, DTS® Neural Surround, PremiDIA-WIDE® surround, and Dolby® Volume
 - SiriusXM® Satellite Radio with 3 mo. pre-paid subscription⁹
 - Leather seating surfaces
 - Power glass sunroof with tilt and slide and one-touch open/close switch
 - Power remote liftgate
 - 8-way power adjustable driver's seat with seat back pocket
 - Wood-grain appearance trim panels (door trim and instrument panel)
- GT Premium Package:** Optional for GT S-AWC
- 710-watt Rockford-Fosgate® premium sound system with 9 speakers including 10 in. dual-voice coil subwoofer with Punch Control®, DTS® Neural Surround, PremiDIA-WIDE® surround, and Dolby® Volume
 - Leather seating surfaces
 - Power remote liftgate
 - Power glass sunroof with tilt and slide and one-touch open/close switch
 - Power remote liftgate
 - 8-way power adjustable driver's seat with seat back pocket
- SE Touring Package:** Optional for SE FWD and SE S-AWC
- MMCS Navigation system with 7 in. high definition touch panel, voice command, 3D mapping, point-of-interest information, real-time traffic (replaces std. audio system head unit), and Mapcare® with two complimentary map updates
 - 710-watt Rockford-Fosgate® premium sound system with 9 speakers including 10 in. dual-voice coil subwoofer with Punch Control®, DTS® Neural Surround, PremiDIA-WIDE® surround, and Dolby® Volume
 - SiriusXM® Satellite Radio with 3 mo. pre-paid subscription⁹
 - Adaptive Cruise Control (ACC) system³
 - Forward Collision Mitigation (FCM) system⁵
 - Lane Departure Warning (LDW) system⁴
 - Auto on/off headlights
 - Rain-sensing windshield wipers
 - Leather seating surfaces
 - Power glass sunroof with tilt and slide and one-touch open/close switch

FACTORY PACKAGES (Cont.)

- Power remote liftgate
 - 8-way power adjustable driver's seat with seat back pocket
 - Wood-grain appearance trim panels (door trim and instrument panel)
- GT Touring Package:** Optional for GT S-AWC
- MMCS Navigation system with 7 in. high definition touch panel, voice command, 3D mapping, point-of-interest information, real-time traffic (replaces std. audio system head unit), and Mapcare® with two complimentary map updates
 - 710-watt Rockford-Fosgate® premium sound system with 9 speakers including 10 in. dual-voice coil subwoofer with Punch Control®, DTS® Neural Surround, PremiDIA-WIDE® surround, and Dolby® Volume
 - Adaptive Cruise Control (ACC) system³
 - Forward Collision Mitigation (FCM) system⁵
 - Lane Departure Warning (LDW) system⁴
 - Leather seating surfaces
 - Power glass sunroof with tilt and slide and one-touch open/close switch
 - 8-way power adjustable driver's seat with seat back pocket
 - Power remote liftgate

OPTIONS

Navigation System:

- Navigation system with 7 in. high definition touch panel, voice command, 3D mapping, point-of-interest information, real-time traffic (replaces std. audio system head unit), and Mapcare® with two complimentary map updates

Exterior Package:

- Available on SE and GT
- Large rear spoiler
- Front, side, and rear airdams
- Front undercover

Entertainment Package

- Rear seat DVD player
- Remote control
- Infrared wireless headphone (1)

Interior Package A:

- Available on ES and SE
- Aluminum/leather shift knob
- Piano black accent panels

Cargo Package

- Cargo tray
- Cargo net

Interior Package B:

- Available on ES and SE
- Aluminum/leather shift knob
- Brushed silver accent panels

All Weather Package

- Remote engine start
- All-weather floor mats (4)

Protection Package

- Scuff plates
- Body side moldings

Towing Package

- Tow hitch
- Trailer tow wire harness

LED Illumination Package

- Floor illumination (Blue LED)
- Liftgate illumination (Blue LED)
- Interior lights

Wind Deflector Package

- Side wind deflectors
- Hood protector

Rear Park Assist Sensors Package

- Front and rear park assist sensors

Chrome Package:

- Available on SE and GT
- Door handle covers
- Sideview mirror covers

ACCESSORIES

- Roof Rack Crossbars:** Available in all trims
- Fog Lights:** Available on ES
- Wheel Locks:** Available on SE and GT
- Tonneau Cover:** Available in all trims
- All Weather Floor Mats (4):** Available in all trims
- Mudguards:** Available in all trims (front and rear mudguards)

[–] Not Available [STD] Standard [OPT] Factory Package [ACC] Accessory
Features and options subject to change without notice.

INTERIOR

SEATS SIDE VIEW

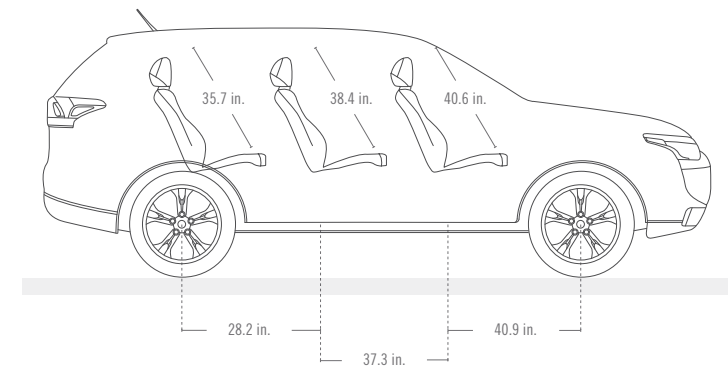

SEATS TOP VIEW

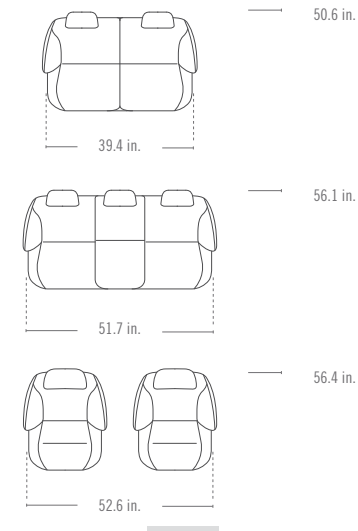

INTERIOR DIMENSIONS

Head Room (with sunroof)		Shoulder Room	
Front	40.6 in. (39.9 in.)	Front	56.4 in.
2nd row	38.4 in. (37.2 in.)	2nd row	56.1 in.
3rd row	35.7 in. (35.7 in.)	3rd row	50.6 in.
Leg Room		Hip Room	
Front (MAX)	40.9 in.	Front	52.6 in.
2nd row	37.3 in.	2nd row	51.7 in.
3rd row	28.2 in.	3rd row	39.4 in.

SAE passenger volume	128.2 cubic ft.
SAE cargo volume – behind front seats (est.)	63.3 cubic ft.
SAE cargo volume – behind 2nd row seats (est.)	34.2 cubic ft.
SAE cargo volume – behind 3rd row seats (est.)	10.3 cubic ft.

FOOTNOTES

- The Bluetooth® word mark and logos are owned by the Bluetooth SIG, Inc., and any use of such marks by Mitsubishi is under license.
- iPod is a registered trademark of Apple Computer, Inc.
- ©2013 Rockford Corporation. All Rights Reserved. ROCKFORD FOSGATE, PUNCH and associated logos where applicable are registered trademarks of Rockford Corporation in the United States and/or other countries. Specifications subject to change without notice.
- Sirius services require subscriptions, sold separately after 3-month trial included with vehicle purchase. See our Customer Agreement for complete terms at www.siriusxm.com. If you decide to continue your Sirius services at the end of your trial subscription, the plan you choose will automatically renew and bill at then current rates until you call SiriusXM at 1-866-635-2349 to cancel. Programming subject to change. Sirius satellite service available only to those at least 18 and older in the 48 contiguous USA, D.C., and PR (with coverage limitations). Sirius, XM and all related marks and logos are trademarks of Sirius XM Radio Inc.
- EPA estimates are to be used as a standardized comparison with other vehicles. Your actual mileage will vary depending on how you drive and maintain your vehicle.

COLOR AND TRIM

EXTERIOR COLORS



ES FWD



SE FWD



SE S-AWC

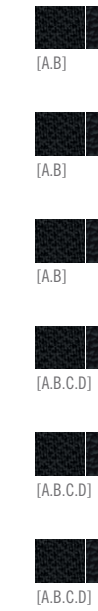

GT S-AWC

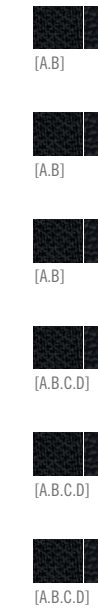

INTERIOR COLORS

[A] Black Premium Sport Fabric



The letters indicate interior colors/trims available with exterior vehicle color.

[B] Black Leather

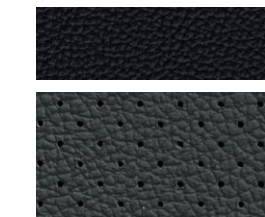

[C] Beige Premium Sport Fabric

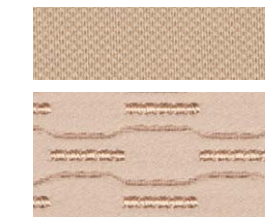

[D] Beige Leather



WARRANTY

Powertrain	10 year/100,000 mile limited warranty
Basic	5 year/60,000 mile limited warranty
Anti-corrosion/Perforation	7 year/100,000 mile limited warranty
Roadside assistance	5 year/unlimited mile

Log on to our website and browse our full lineup of new vehicles, get MSRP and customer rebate information and "build" the Mitsubishi that's right for you. The site can help you locate your nearest dealer - or even have a dealer contact you. MITSUBISHICARS.COM

See retailer for limited warranty and roadside assistance terms and conditions.

The 10-year/100,000-mile Limited Powertrain Warranty applies only to the original owner of new, retailed 2014 models purchased from an authorized Mitsubishi dealer. Subsequent owners receive the balance of the New Vehicle Limited Warranty of 5 years/60,000 miles. Different coverage applies to the Mitsubishi i-MiEV, Lancer RALLIART and Evolution. The Mitsubishi i, Lancer RALLIART and Evolution have 3-year/36,000-mile coverage for New Vehicles and 5-year/60,000-mile coverage for Limited Powertrain Warranty.

Technical data, equipment and options shown are based on the latest information available at the time of printing and are subject to change without notice. Colors may vary due to the printing process. Exterior and interior lights on vehicles shown may be illuminated for illustration purposes only. Vehicles are shown with optional equipment. Not all equipment is available on every model. For more complete details about equipment configuration and Mitsubishi Genuine Accessories, please contact your Mitsubishi Retailer.

SPECIFICATIONS

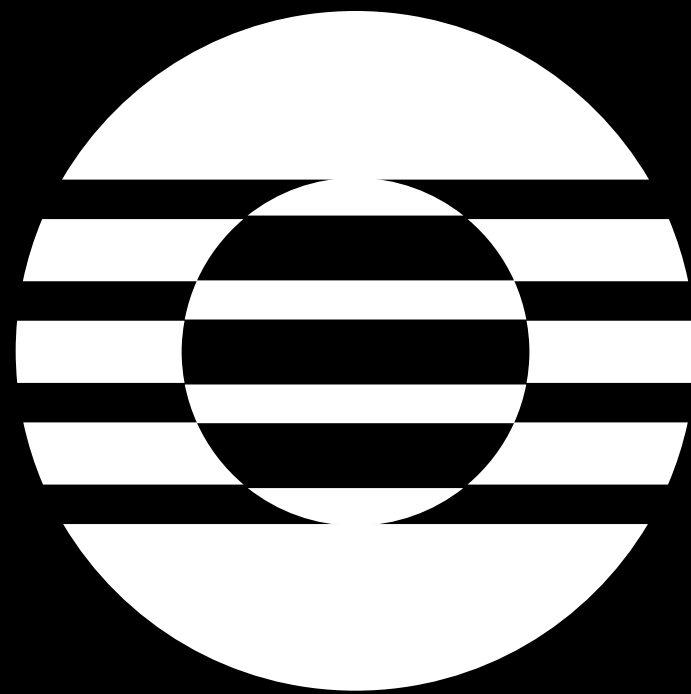

Model

ES FWD
SE FWD
SE S-AWC
GT S-AWC

EXTERIOR

FRONT VIEW

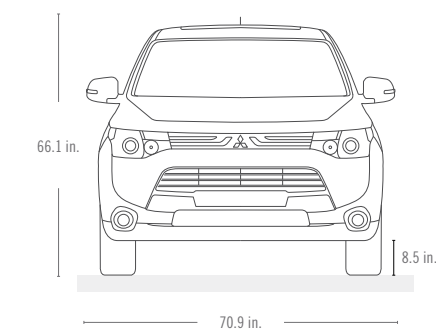

SIDE VIEW

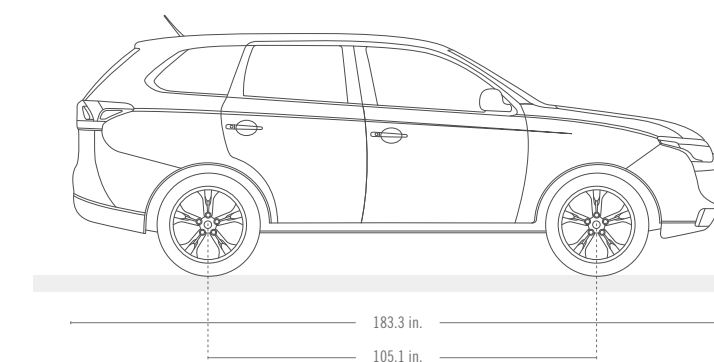

EXTERIOR DIMENSIONS

Wheelbase	105.1 in.
Overall length	183.3 in.
Ground clearance	8.5 in.

	ES FWD	SE FWD	ES S-AWC	GT S-AWC
Overall width	70.9 in.	70.9 in.	70.9 in.	70.9 in.
Overall height	66.1 in.	66.1 in.	66.1 in.	66.1 in.
Wheel tread, front	60.6 in.	60.6 in.	60.6 in.	60.6 in.
Wheel tread, rear	60.6 in.	60.6 in.	60.6 in.	60.6 in.

FOOTNOTES

- Based on EPA highway mileage rating. Actual mileage may vary.
- Airbags are part of a Supplemental Restraint System (SRS). To decrease the risk of injury from a deploying airbag, always wear your seat belt, sit upright in the middle of the seat, and do not lean against the door. Always place children 12 and under in the rear seat and use appropriate child restraints. Never place a rear-facing infant restraint in the front seat. See your Owner's Manual and instructions provided with your child restraint for additional information.
- The Adaptive Cruise Control system is not a collision avoidance system or an automatic driving system. It is designed to use only limited braking and is never a substitute for safe and careful driving. Never rely solely on the Adaptive Cruise Control system.
- The Lane Departure Warning system is designed to read the lane marks under certain conditions. It is not a collision avoidance system and is not a substitute for safe and careful driving.
- The Forward Collision Mitigation system is designed to help avoid or reduce the crash speed in certain frontal collisions. It is not a substitute for safe and careful driving. Under certain circumstances, the system may not operate or may not detect a frontal vehicle correctly.

Mitsubishi Motors. California, USA.



At Mitsubishi, we believe not all drivers are created equal. So we build our vehicles for a different breed of driver, the fearless ones who take pride in what they drive, and refuse to drive more of the same. It's obvious to us that people who truly want distinctive styling and the latest technology see past the procession of bland imitations. We believe that every vehicle we make should stand for something. Something more than expected. And that's why we don't build Mitsubishi cars for stereotypes. We build them for you.

MITSUBISHICARS.COM 1.888.MITSU2014

NATLBRO-14-003