

...now **BIGGER & BETTER!**



*The*  
**4-WHEEL DRIVE**  
**LAND** —  
— **ROVER**

THE *"Go anywhere"* VEHICLE



# More & more Farmers, Countrymen

with The

# LAND ROVER



The Land-Rover makes light

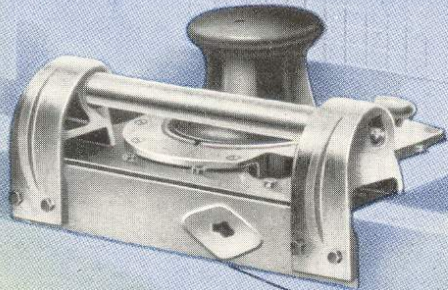

Capstan winch fitted to the front of the Land-Rover, designed for a 2,500 lb. (1,135 Kg.) pull.

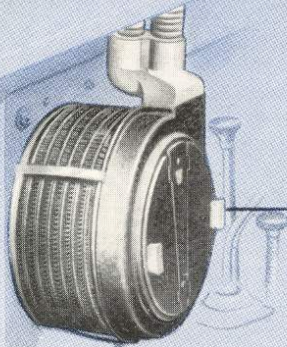

Combined heater and screen demister fitted in the Land-Rover driving compartment.

Alternative position for carrying the spare wheel ; a special fitting can be supplied.



This view shows the clean, workmanlike design of the Land-Rover built for really hard going and specially treated against corrosion. The gearbox, and the drive to the front and rear axles is from the transfer box and tubular type shock-absorbers are fitted front and rear. Right or left

Also illustrated are some of the items of optional equipment which for a wide variety of jobs in agriculture and industry. Designed to do what it could possibly perform, the four-wheel drive Land-Rover has almost any world.

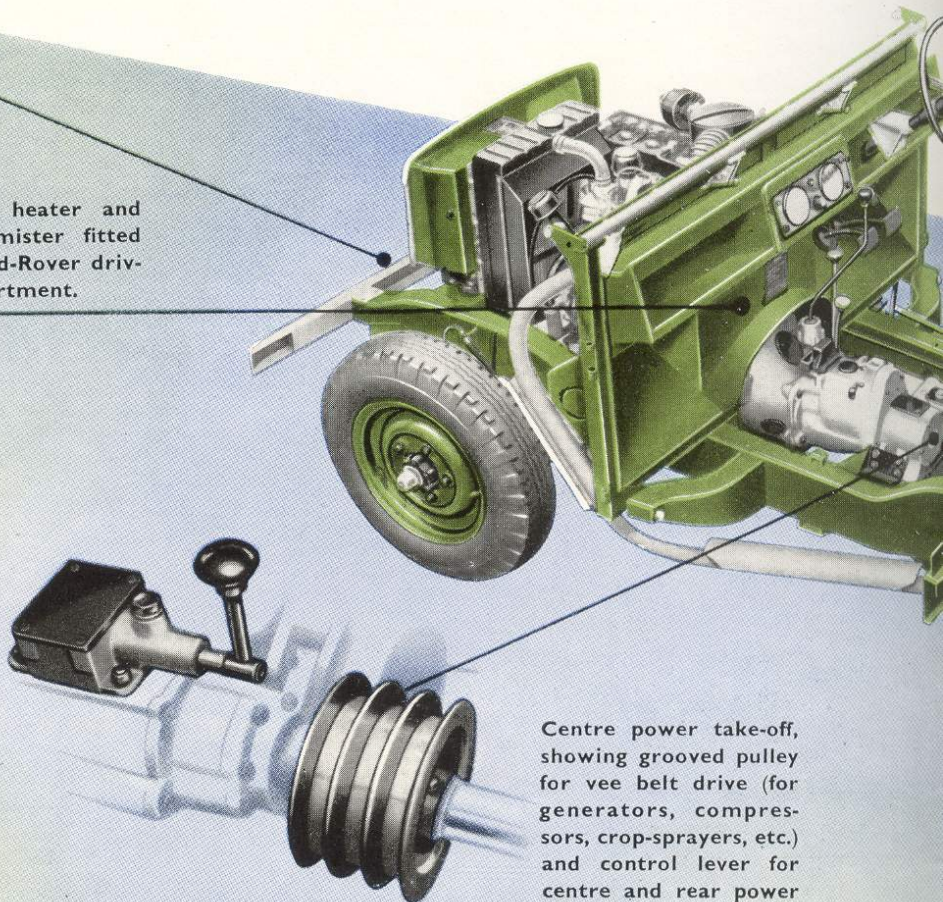

Centre power take-off, showing grooved pulley for vee belt drive (for generators, compressors, crop-sprayers, etc.) and control lever for centre and rear power take-offs.

# Industrialists are doing more jobs

# ROVER

By Appointment to the  
Manufacturers of  
The Rover



late King George VI  
Land-Rovers  
Co., Ltd.

Mud, sand, scrub, steep rocky slopes — the Land-Rover is the master of them all.



chassis, and illustrates the immensely rigid box section chassis frame—  
The drive for centre and rear power take-offs is taken through the main  
ox. The suspension system is capable of dealing with the roughest ground,  
left-hand steering can be fitted as required.

make the Land-Rover a highly mobile power-unit, eminently suitable  
to operate in all conditions, built for work that no ordinary vehicle  
ready proved itself invaluable for every kind of task throughout the

Rear power take-off fitted with  
pulley unit for belt drive.

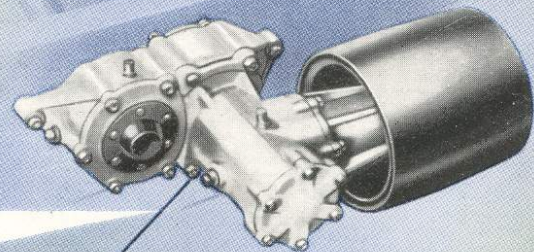

Rear power take-off, show-  
ing positive splined shaft  
drive and protecting cowl.

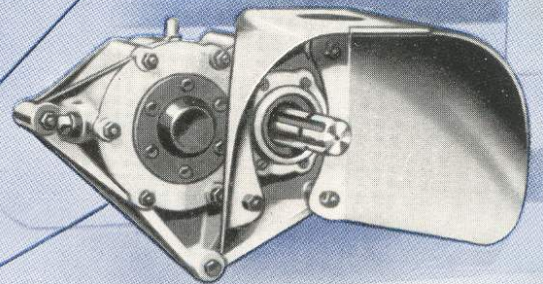

Folding rear seats can be fitted for  
carrying additional passengers.

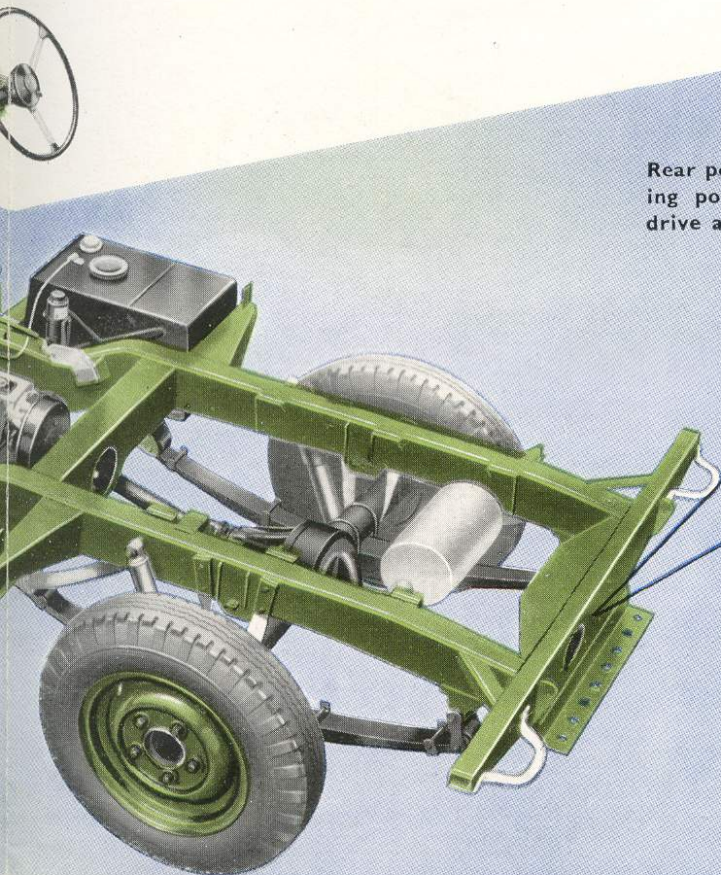
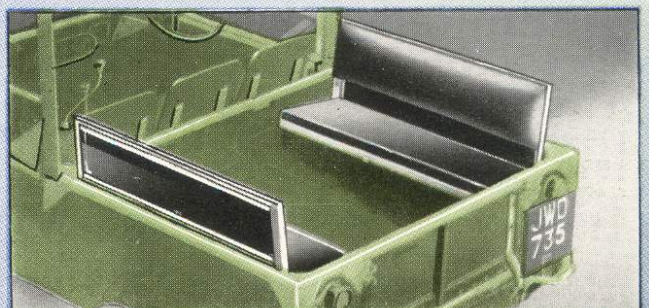

# More & more Farmers, Countrymen

with The **LAND-ROVER**



The Land-Rover makes light work of a load like this, however tough the going may be.



Operating a power-driven mower—one of the many uses of the rear power take-off.

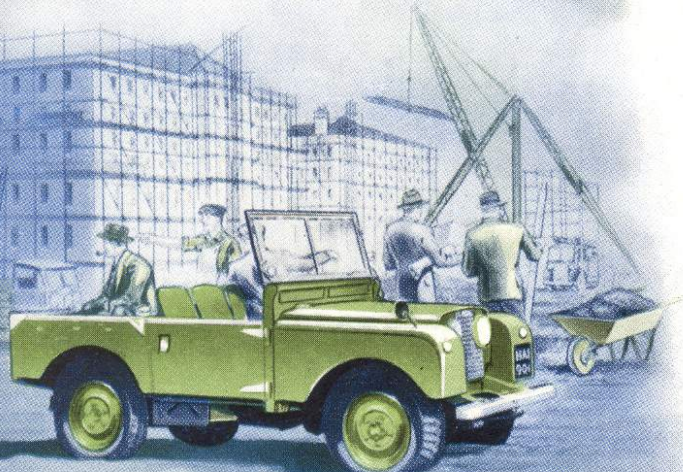

Building, contracting, surveying—wherever there's a job of work to be done the Land-Rover will be there.

## 4-WHEEL DRIVE

A LARGER LAND-ROVER •  
LONGER WHEELBASE • INC

Since its introduction in 1948 the Land-Rover and successfully accomplished every task set for it. The new four-wheel drive vehicle takes another step forward, giving 25% more carrying capacity and a strengthened compartment in which particular attention has been given to adequate ventilation. The control pedals and gear and other new features include a new carrying capacity, a floor completely flat, flush-fitting exterior door handles, read instruments and extremely handy parcel shelves.

The Land-Rover has a 4-cylinder, 2-litre engine, two power windows and two reverse, and can be driven either in four-wheel or in two-wheel drive. In four-wheel drive when in low transfer. The rear power take-off will operate farm implements, etc., and the centre power take-off will operate other equipment mounted in the body of the vehicle (1,135 Kg.) pull, and the vehicle will haul loads many times its own weight in alloy, and all exterior steel fittings are heavily galvanised.

In standard form the Land-Rover is supplied with a water tank (below, right). As an alternative a strong, easily removable top (left), fitted or removed in a matter of minutes. Also available is a detachable top over the driving compartment, giving the driver and the passenger a more comfortable ride. The detachable top and the truck cab can also be fitted with a d

The Land-Rover can also be supplied as a fire-fighting vehicle to tackle the most difficult going and

# Industrialists are doing more jobs

# ROVER LIVE VEHICLE

By Appointment to the  
Manufacturers of  
The Rover



late King George VI  
Land-Rovers  
Co. Ltd.

**MORE CARRYING CAPACITY  
CREASED DRIVING COMFORT**

er has taken the world as its proving ground  
t for it. Now this all-purpose, go-anywhere,  
ward with a longer wheelbase and a longer body  
steadier ride, and a more comfortable driving  
s been paid to thorough weather-proofing and  
gear lever are re-positioned for easier operation,  
bracket for the spare wheel that leaves the body  
handles, and a new instrument panel with easily  
helves.

ver take-off points (centre and rear), eight forward speeds  
in two-wheel drive in high transfer gear, but is permanently  
ake-off is suitable for shaft-driven or belt-driven machinery,  
operate, via vee belts, generators, compressors, crop-sprayers  
le. A front winch is available, designed for a 2,500 lb.  
es its own weight. Body panels are in non-corrodible light

erproof canvas hood covering the driving compartment and  
detachable lightweight metal top can be supplied (below,  
available as an optional extra is a metal truck cab which fits  
front-seat passengers perfect protection. Both the metal  
double-skin tropical roof.

icle, where its four-wheel drive and compactness enable it  
g and to approach much nearer to

Mud, sand, scrub, steep  
rocky slopes — the Land-  
Rover is the master of  
them all.



On the farm  
the Land-Rover is the  
complete maid-of-all-work. Here it  
operates a threshing machine  
through the rear power take-off.



A Land-Rover and trailer at the  
docks, where its manœuvrability  
is invaluable.

and other special Land-Rover vehicles

The Land-Rover is justifiably called a "versatile vehicle". Comfortable, fast and equally at home across the country, adaptable for agricultural uses or as a positive glutton for work, anywhere and take almost any job.

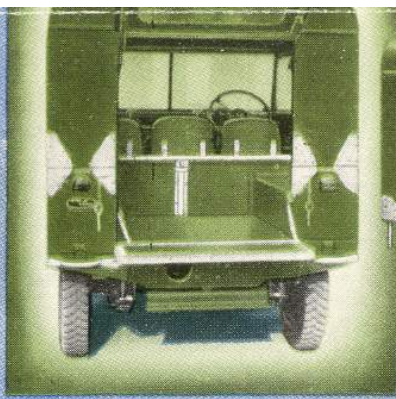

The lightweight metal detachable top, showing method of removal and (inset) the lift-up rear door.

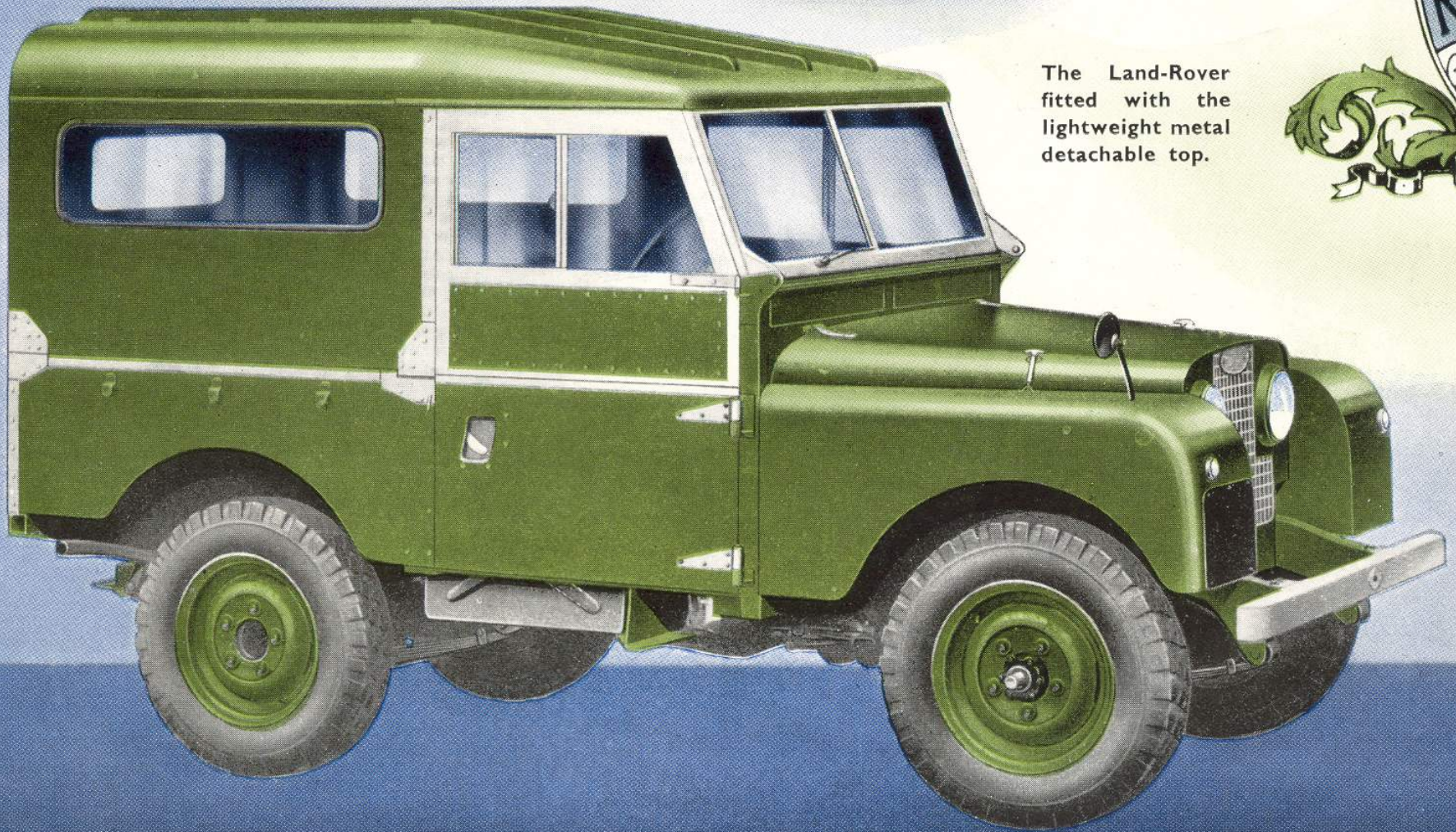
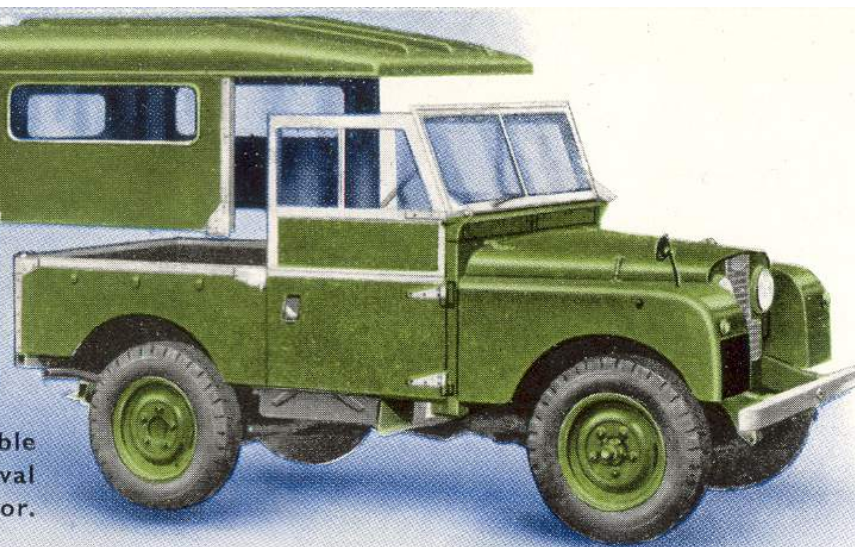

The Land-Rover fitted with the lightweight metal detachable top.



es can be supplied on application.

imed to be "the world's most  
st and economical on the road—  
e roughest country—infinately  
in industry, tremendously tough  
, this amazing vehicle will go  
o in its stride.

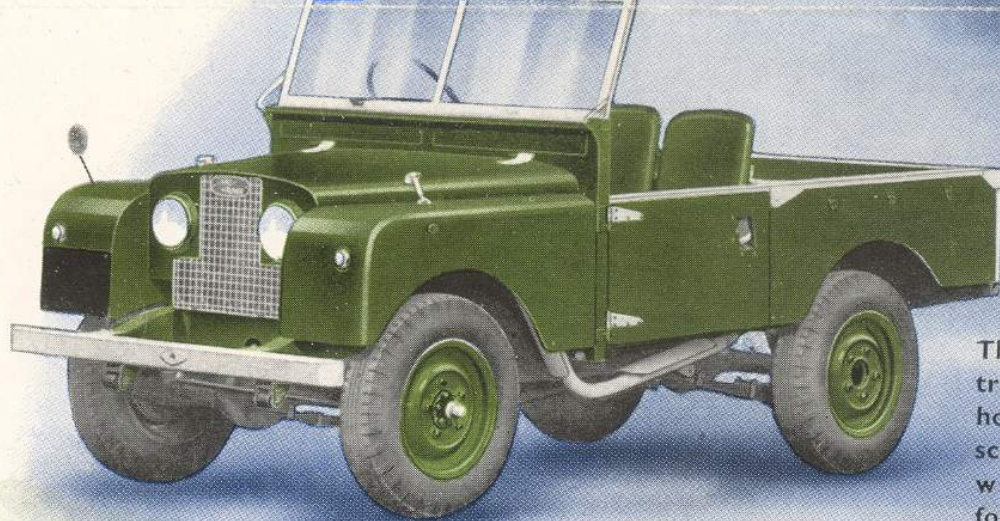

The Land-Rover in open trim, with canvas hood, hood-sticks and side-screens removed. The windscreen can be folded flat.



The Land-Rover with canvas hood and side-screens in position.

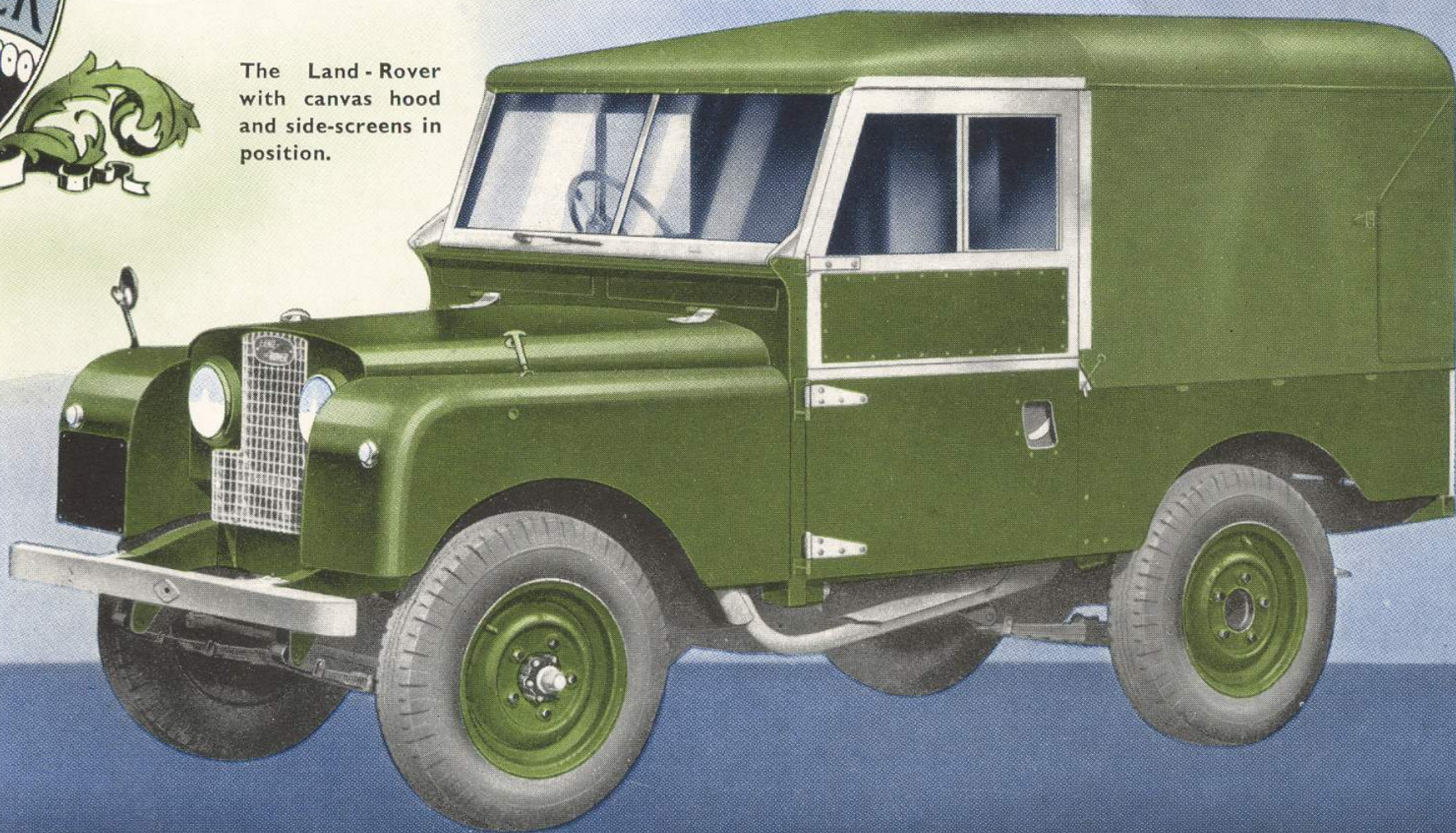

833-

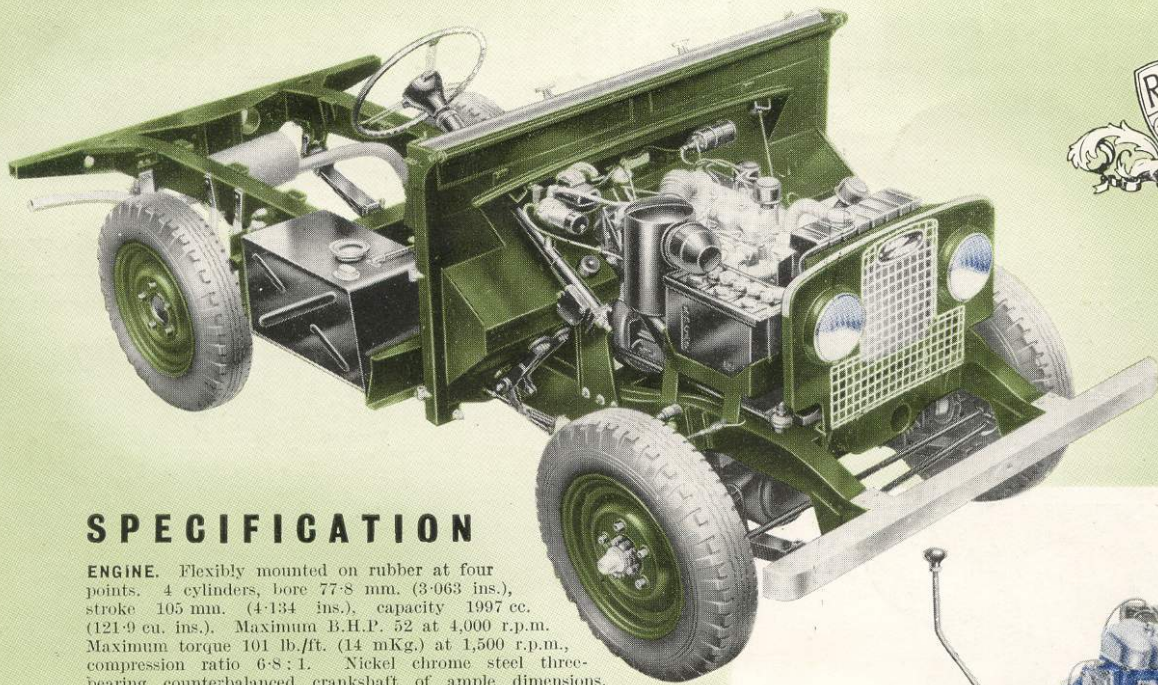

## SPECIFICATION

**ENGINE.** Flexibly mounted on rubber at four points. 4 cylinders, bore 77.8 mm. (3.063 ins.), stroke 105 mm. (4.134 ins.), capacity 1997 cc. (121.9 cu. ins.). Maximum B.H.P. 52 at 4,000 r.p.m. Maximum torque 101 lb./ft. (14 mKg.) at 1,500 r.p.m., compression ratio 6.8:1. Nickel chrome steel three-bearing counterbalanced crankshaft of ample dimensions. Camshaft in crankcase driven by double roller silent chain with hydraulic tensioner. Firing order 1,3,4,2.

**VALVES.** Overhead inlet valves operated by rocker and push rod from camshaft. Side exhaust valves with inserted valve seats operated by rocker in direct contact with camshaft.

**PISTONS.** Aluminium. Inverted V-shaped head to conform to patent design of semi-spherical combustion chamber giving increased compression turbulence. Two compression rings and two scraper rings fitted.

**CLUTCH.** Single dry plate, 9 ins. (230 mm.) diameter.

**DYNAMO.** Automatic voltage regulator, 12v.

**STARTER.** Operates on flywheel.

**CARBURETTOR.** Downdraught.

**PETROL FILTER.** Mounted on engine side of dash.

**AIR CLEANER.** Centrifugal and oil-bath type.

**TRANSMISSION.** Provision for eight forward speeds and two reverse. Transmission to rear and front axle by open propeller shaft via two-speed transfer box.

**BRAKES.** Hydraulically operated foot brakes requiring very light pedal pressure and infrequent adjustment. Mechanically actuated handbrake operates on transmission shaft to rear axle.

**REAR AXLE.** Semi-floating, spiral bevel type. Ratio 4.7 : 1.

**FRONT AXLE.** Fitted with differential similar to rear axle. Drive to front wheels through totally enclosed universal joints.

**COOLING SYSTEM.** Pump and fan, thermostatically controlled. Capacity 17 pints (9.75 litres).

**LUBRICATION.** By pressure from gear type pump forcing oil to all bearings, timing chain and valve gear. Capacity 10 pints (5.5 litres).

**GEARS.** Four forward speeds and reverse. Two-speed transfer box in conjunction with main gearbox gives eight forward speeds and two reverse. Ratios:

Main Gearbox	Transfer box	
	High ratio	Low ratio
First gear ...	16.171	40.688
Second gear ...	11.026	27.742
Third gear ...	7.435	18.707
Top gear ...	5.396	13.578
Reverse gear ...	13.745	34.585

**IGNITION.** Coil and battery, automatic advance. Battery 12v. 51 amp. hr.

**CHASSIS.** Side and cross members of box section forming exceptionally rigid assembly.

**STEERING.** Worm and nut, 15 : 1 ratio. Right or left-hand steering as required.

**FUEL SUPPLY.** 10-gallon (45 litres) tank under right-hand seat.

**SPRINGS.** Semi-elliptic front and rear. Telescopic type shock absorbers front and rear.

**WHEELS.** Detachable disc wheels with 16 in. x 6.00 tyres.

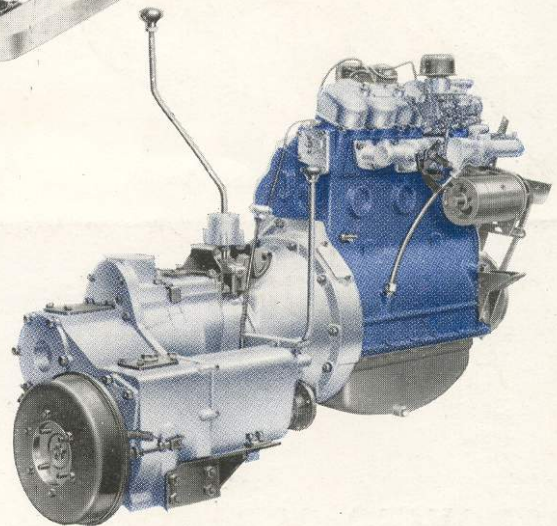

**DIMENSIONS.** Overall width 62 3/8 ins. (1.59 m.) approx. Overall length 140 1/2 ins. (3.58 m.) approx. Wheelbase 86 ins. (2.18 m.). Track 50 ins. (1.27 m.). Height, unladen, 76 ins. (1.93 m.). Weight, unladen, 2,702 lb. (1,226 Kgs.). Turning circle 37 ft. (11.28 m.). Payload 1,000 lb. (454 Kgs.), and driver and two passengers.

**INTERNAL BODY DIMENSIONS.** Length between cappings 45 1/2 ins. (1.162 m.). Width between cappings 57 ins. (1.448 m.). Height of wheel-arch 8 1/2 ins. (220.66 mm.). Width of wheel-arch 12 ins. (304.8 mm.).

**DRAW BAR PULL.** 1,200 lb. to 2,000 lb. (550 to 900 Kgs.).

**REAR POWER TAKE-OFF.** (At extra cost.) Drive through back of main gearbox to rear of chassis. Can be fitted to give pulley drive for threshers, chaff cutters, circular saws, etc., or shaft drive for power mowers, binders, combine harvesters, etc.

**CENTRE POWER TAKE-OFF.** Arranged to drive (by V-belts) compressors, generators, crop-sprayers, and other portable equipment which can be mounted in the body.

**BODY.** Body panels of non-corrodible light alloy, all external steel fittings heavily galvanised.

**RANGE OF COLOUR FINISHES.**

Bodywork ...	GREEN	BLUE	GREY	BEIGE
Upholstery ...	GREEN	BLUE	BLUE	GREEN

The Rover Company Limited reserves the right to alter specifications, designs or prices without notice and without incurring any obligation.

Persons dealing in the Company's goods are not the agents of the Company, and have no authority whatsoever to bind the Company by any expressed or implied undertaking. The Land-Rover is subject to the guarantee contained in the Guarantee Form issued by The Rover Company Ltd.

# THE ROVER COMPANY LTD. • SOLIHULL • BIRMINGHAM • ENGLAND

Telephone : Sheldon 2461

Telegrams : Rover, Solihull

Service Depot : SOLIHULL. Telegrams : Rovrepair, Solihull. London Showrooms : DEVONSHIRE HOUSE, PICCADILLY, W.1. Telephone : Grosvenor 3252

London Service Depot : SEAGRAVE ROAD, FULHAM, S.W.6. Telephone : Fulham 1221. Telegrams : Rovrepair, Wespnone, London.

The name Land-Rover is a registered Trade Mark of The Rover Company Limited.