

1985 Oldsmobile • A Special Feel

Album #1: Ninety-Eight Regency • Delta 88 Royale
Toronado • Custom Cruiser



*There is a special feel
in an Oldsmobile.*

*Welcome to the 1985 Oldsmobile
album of fine cars.*

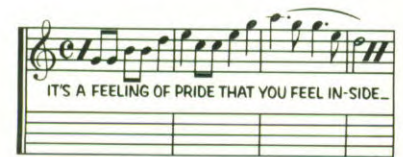

Here you can sample a medley of our newest automotive hits.

Each one a masterwork of style, performance and value. Each one playing out the qualities that make an Olds worth owning.

Everyone, a harmonious blending of all the attributes that give that

special feel to an Oldsmobile.

First, we invite you to enjoy the most recent winner on our hit parade, the 1985 Ninety-Eight Regency. It's a new dimension in Oldsmobile luxury.

Next, music to your ears—Delta 88 Royale, the family car that didn't

forget the family. It offers a lot of value and family comfort.

Then, the Oldsmobile Toronado, an exciting arrangement of style and performance in a personal luxury car.

Finally, Custom Cruiser. Big, roomy and elegant, a perennial favorite on the station wagon charts.

And like all Oldsmobiles—each one has been meticulously orchestrated by people who care about the quality of what they do.

Yes, there is a special feel in an Oldsmobile and for 1985, it goes like this...



Ninety-Eight Regency Brougham Sedan

*Carries you with taste, refinement
and impeccable manners.*



Here is a thoroughly "polished" luxury car, inside and out. It reflects the latest in Oldsmobile technology with unsurpassed luxury. Inside, elegant accommodations for six. Outside, a lustrous new multi-coat/

high-gloss enamel finish. Under the hood, the smooth, spirited performance of a 3.8-liter multi-port fuel injected V6 or available 4.3-liter diesel V6. On the road, Oldsmobile's precise road management system. It

combines front-wheel drive, rack-and-pinion steering, four-wheel independent suspension and electronic load levelers to provide a luxury-car ride second to none.



Ninety-Eight Regency Brougham

*All the comforts of a private club, including
the elegant appointments.*



It's quiet. It's restful. It's inviting and comfortable. Traditional Oldsmobile luxury for six. Interiors feature rich velour seats or available genuine leather in the seating areas. Behind the wheel, 6-way power control for

the driver's seat is standard, while a "memory seat" which can be preset for two drivers is available. To add to the comfort and luxury, consider the advanced technology also available: electronic instrument panel,

electronic auto calculator and trip computer, voice information reminder system, electronic day-night mirror, and for the ultimate in sound, the electronically tuned Delco-GM/Bose music system.



Ninety-Eight Regency Brougham Coupe.

*It will move you with its pure luxury
and precise road management.*



A luxury car of this stature deserves a luxury ride to match: precise road management. Your Ninety-Eight Regency tracks sure and true with front-wheel drive and rack-and-

pinion steering. Bumps and shock are effectively neutralized by four-wheel independent suspension. Weight distribution is automatically equalized by an electronic load level-

ing system. Even the engine and suspension have been isolated from the body for quiet comfort.



Ninety-Eight Regency Sedan and Coupe

*The marriage of logic and luxury:
advanced technology with gracious accommodations.*



Ninety-Eight Regency is the "thinking man's" luxury car. Having evaluated other luxury cars, Regency owners have concluded that Regency best serves their interests. They respond to traditional Oldsmobile luxury

and new advanced technology. They applaud the economy of the 3.0-liter V6, the available 3.8-liter multi-port fuel injected V6 and 4.3-liter diesel V6. They appreciate such standard features as Four-

Season air conditioning, Tilt-Wheel Steering, 6-way power seat for the driver—and more—all included in Regency's reasonable price.

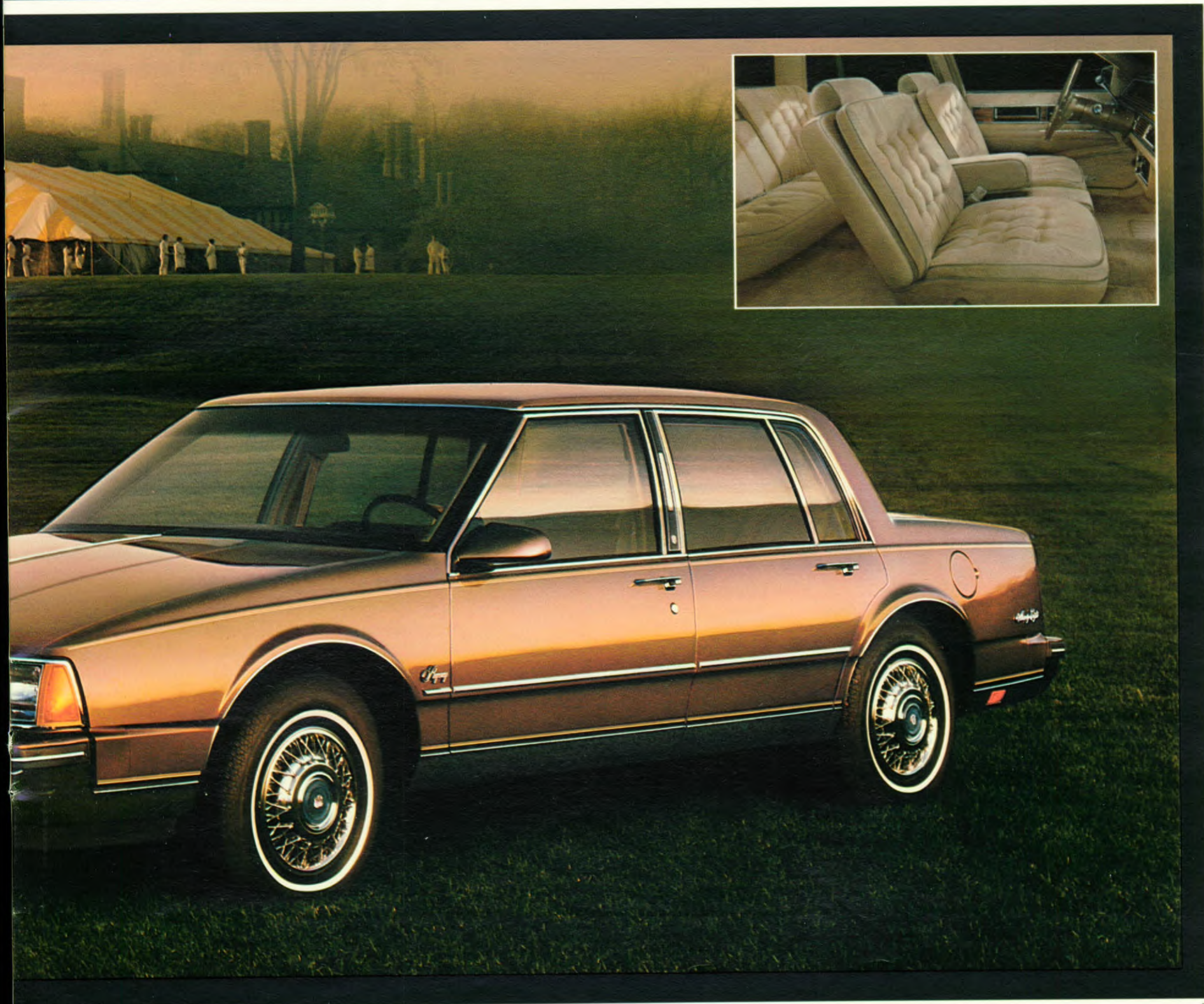

Ninety-Eight Regency

Facts, figures and features.

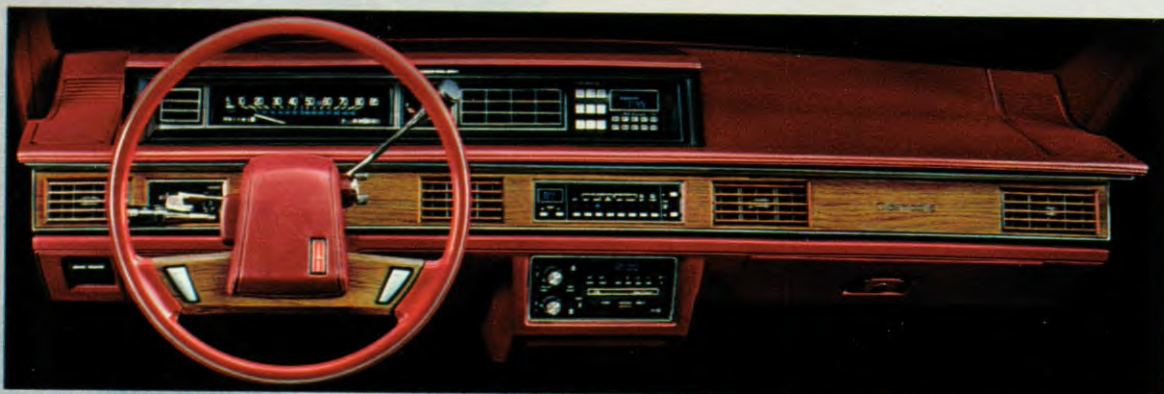

There's a special feel behind this wheel.



Power side window defogger. Helps provide a clear view of outside rearview mirrors. Standard.



High-intensity dual rear seat reading lamps are standard on Brougham models.



A "memory seat." Allows two drivers to pre-select desired positions, then commit them to computer memory. Available.



Discover the special feel of luxury with genuine leather in the seating areas. Available.



Electronic instrument panel cluster is available. May be ordered with optional 19-function auto calculator and handy voice information reminder system.



Power windows, 6-way power seat (driver's side), standard; "memory seat" and electric outside left/right mirrors, available.

New electronic 14-function auto calculator/trip computer. Available. New Electronic Comfort Control air conditioner with digital temperature display standard on Regency Brougham. Electronically tuned AM/FM stereo standard. (May be deleted for credit.)



Spacious 15.7 cubic feet of luggage. Deluxe trunk trim and spare tire cover are standard.



Deluxe Wheel Disc (left) standard on Regency. Simulated Wire Wheel Disc with lock (center) standard on Brougham, available on Regency. Aluminum-Styled Wheel (right) available.

An inside look at Ninety-Eight...

NINETY-EIGHT REGENCY STANDARD EQUIPMENT

Chassis and Body:

■ Transverse-Mounted Engine with Front-Wheel Drive ■ Computer Command Control ■ Unit Body Construction ■ Four-Wheel Independent Suspension with MacPherson Front Struts ■ Automatic Leveling System ■ Extensive Anti-Corrosion Treatment ■ Power Front Low-Drag Disc Brakes ■ Power Rack-and-Pinion Steering ■ High-Energy Ignition System ■ Maintenance-Free Battery ■ Delcotron ■ Dual Remote Control Outside Mirrors ■ Compact Spare Tire ■ Lower Body Side, Belt Reveal, Roof Drip, Rocker Panel and Wheel-Opening Moldings ■ Body Side Moldings with Inserts (Regency Brougham models) ■ Headlamps with Tungsten Halogen High Beams ■ Front Fender Cornering Lamps (Regency Brougham models) ■ Pillar-Mounted Opera Lamps ■ Padded Vinyl Landau Rooftop Covering (Regency/Regency Brougham Coupe models) ■ Easy-Roll, High-Pressure, White-Stripe All-Season Tires ■ Deluxe Wheel Discs (Regency models) ■ Simulated Wire Wheel Discs with Locks (Regency Brougham models) ■ Deluxe Trunk Trim with Spare Tire Cover

Interior:

■ Electronic Comfort Control Air Conditioner (Regency Brougham models) ■ Four-Season Air Conditioner ■ Armrests, Front and Rear Seat, Center ■ Wall-to-Wall, Cut-Pile Carpeting with Carpeted Lower Door Panels ■ Cigar Lighters, Instrument Panel and Rear Doors ■ Convenience Package of Lamps, Visor Vanity Mirror and Chime Tones ■ Power Door Locks ■ Door-Pull Handles ■ Hood Lock Release, Interior Operated ■ Instrument Panel Simulated Regency Walnut Grain Trim ■ Trip Odometer ■ Header Panel Reading Lamp ■ Lamp Switches at all Doors ■ Remote Control Outside Mirrors, Driver and Passenger Side ■ ETR™ AM/FM Stereo Radio with Digital Quartz Clock, Two Rear Speakers and Fixed Mast Antenna (may be deleted for credit) ■ Full-Foam Seat Construction

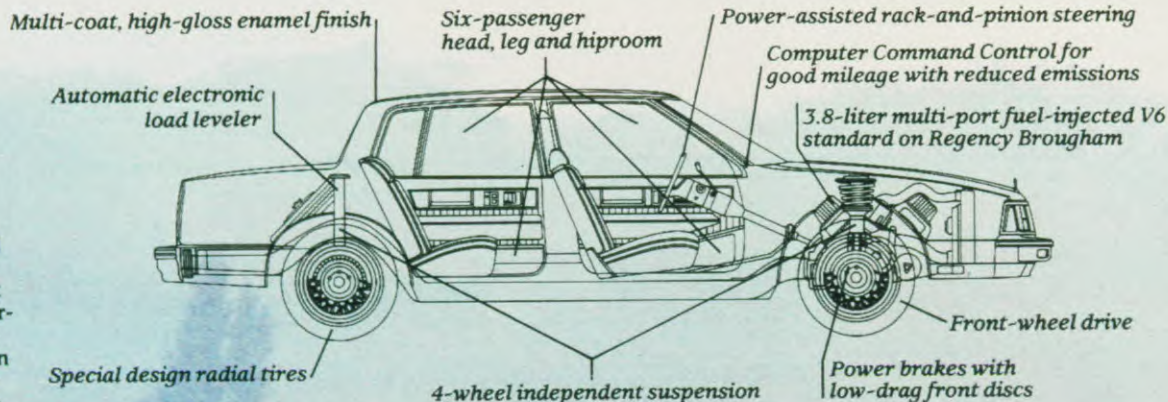

NINETY-EIGHT REGENCY POWER TEAMS		LITER/TYPE		DIMENSIONS:		Legroom		Coupe/Sedan:		
Standard Engine:*	3.8/V6	Carburetion	Multi-Port Fuel Injection	Overall length (in.)	196.4	Front (in.)	42.4/42.4	Rear (in.)	40.8/40.8	
(Regency models)	3.0/V6	Available Engine:*	4.3/V6 Diesel	Wheelbase (in.)	110.8	Shoulder Room	Front (in.)	58.9/58.9	Rear (in.)	57.6/58.8
Liter/Type	2-Barrel	Liter/Type	4-Speed Automatic Overdrive with Torque Converter Clutch	Luggage Cap. (cu. ft.)	15.7	Fuel Tank (gals.)	18.0			
Standard Engine:*		Standard Transmission		Headroom	Coupe/Sedan:					
(Regency Brougham, available Regency models)				Front (in.)	39.3/39.3					
				Rear (in.)	38.1/38.1					

■ Divided Front Seat with Dual Controls—Driver Side 6-Way Power, Passenger Side, Manual ■ Deluxe Seat Belts, Color Coordinated to Individual Interiors ■ Power Side Windows ■ Power Side Window Defoggers ■ Deluxe Steering Wheel with Tilt-Away feature (Regency Brougham models) ■ Soft-Ray Tinted Glass.

STANDARD EQUIPMENT BY MODEL

Ninety-Eight Regency Brougham:

■ Engine, 3.8-liter V6, with Multi-Port Fuel Injection ■ 4-Speed Automatic Overdrive Transmission with Torque Converter Clutch features ■ Specific Model Identification ■ Five Prima Velour Standard Trims ■ Simulated Wire Wheel Discs with Locks ■ Front Fender Cornering Lamps ■ Sail Panel Reading Lamps ■ Body Side Moldings ■ Landau-Padded Vinyl Rooftop Covering (Brougham Coupe) ■ Deluxe Steering Wheel with Tilt-Away feature ■ Pulse Windshield Wiper system ■ P205/75R14 Steel-Belted Radial-Ply, White-Stripe All-Season Tires

Ninety-Eight Regency:

■ Engine, 3.0-liter V6, 2-Barrel ■ 4-Speed Automatic Overdrive Transmission with Torque Converter Clutch features ■ Five Empress Velour Standard Trims ■ P205/75R14 Steel-Belted Radial-Ply, White-Stripe All-Season Tires ■ Bright Deluxe Wheel Discs.

AVAILABLE EQUIPMENT:

6-Way Power Seat Adjuster, Passenger Side

- 6-Way Power Seat Adjuster, Driver Side—with 2-Position Memory feature
- Reclining Seat Back—Driver/Passenger, Manual; or Passenger Side, Power
- Power Trunk-Lid Lock Release
- Auxiliary Floor Mats with Carpet Inserts, Front and Rear
- Luggage Compartment Floor Mat
- Body Side Moldings (std. on Regency Brougham)
- Door-Edge Guards
- Full Vinyl-Padded Roof Covering (Sedan)
- Electric Rear Window Defogger
- Electronic Air Conditioner (std. on Regency Brougham)
- Sail Panel Reading Lamps (Std. on Regency Brougham)
- Automatic Power Door Locks
- Front Door Locks and Interior Illumination Package
- Electrically Operated Outside Rearview Mirrors, Driver and Passenger Side
- Front Seat Litter Container
- Illuminated Visor Vanity Mirror, Passenger Side
- Body Side Accent Stripes

- Engine Block Heater
- Diesel Engine Block and Fuel-Line Heater
- Automatic Inside Day-Night Mirror
- Firm Ride and Handling Package
- Fuel Filler Door Lock with Electric Remote Release
- Voice Information Reminder System
- Auto Calculator with Digital Readout
- Electronic Instrument Panel Cluster
- Deck Lid Luggage Carrier
- Automatic Cruise Control with Resume and Acceleration Features
- Tilt-Away Steering Wheel (Std. on Brougham Sedan)
- Tilt-and-Telescope Steering Wheel
- Simulated Wire Wheel Discs with Locks (Std. on Regency Brougham)
- Pulse Wiper System
- Combination Dome and Dual Lens Reading Lamp
- Body Side Two-Tone Paint Scheme
- High-Capacity Battery
- Electric Sliding Glass Astrorooftop (Headroom is reduced with this option)
- Puncture-Sealing Tires
- Cornering Lamps (Std. on Regency Brougham)
- Instrument Panel Gage Cluster
- Aluminum-Styled Wheel
- Bumper Guards, Rear
- Exterior Lamp Monitor, Front and Rear
- Special Glamour Metallic Paints in Medium Blue, Dark Sandstone, Champagne
- Reminder Package, Indicators
- High-Capacity Engine Cooling Systems (Not avail. on V6 diesel)
- Custom Leather Trims in seating areas Maple Red and Medium Beige (Regency); Medium Gray and Maple Red (Regency Brougham)
- Trailer Electrical Wiring Harness
- Litter Container
- Rear Bumper Guards
- High-Center Mounted Stop Lamp
- Radios and Tape Players (See Page 35)

*See EPA mileage estimates in accompanying Fuel Economy Estimate Sheet.

Let's get it together... buckle up.

The Oldsmobile Story.

*It's the quality that makes
an Olds worth owning.*

There is a transformation taking place in the American automotive industry. And Oldsmobiles are at the very core of it.

It is a rebirth that is literally redefining the way quality is designed and built into Oldsmobile cars.

This transformation is designed to go beyond your expectations of what a quality car should both look like and behave like.



Quality starts with design.

You'll find this quality reflected in the luxurious Oldsmobiles shown in this catalog. The Toronado. The Delta 88 Royale. The Custom Cruiser. And, especially, the new Ninety-Eight Regency.

For example . . .

Before the 1985 Ninety-Eight Regency could be built, the way cars are built had to be revolutionized.

It starts with quality people working together, pooling their

resources, everyone an expert at their chosen craft.

It is stylists who, from the very beginning, understood that design engineers had to be able to implement what they had envisioned.

And manufacturing and production engineers who had to know how to build what the stylists and designers created.

It is teams of workers with intensive preparatory training—both in classroom instruction and actual hands-on experience—in robotics, pneumatics, hydraulics, electronics, micro-circuitry and more.

Today, quality requires tools that never existed.

Space-age tools. High-tech tools. The same type of tools that helped America to reach new heights in outer space.

These state-of-the-art devices are the keys that allowed a high standard of quality to be designed into the Oldsmobile Ninety-Eight Regency.

From the start, CAD/CAM—computer-assisted design and computer-assisted manufacture—was an important part of the forward planning that went into the Ninety-Eight Regency. And that regulated its progress thereafter.

183 robots—some as big as a two-story building, some as small as a personal computer—



1. Computers aid in design and manufacture. 2. Worker team. 3. Robotic spray booth. 4. Instrument panel checking station. 5. ELPO bath of rust-resistant primers. 6. Robogate body framing. 7. Final computerized process check.

are used to weld and paint with uncanny precision.

**Putting it all together:
five automated body systems.**

They are designed to assure the strength, accuracy and integrity of the Ninety-Eight body structure.

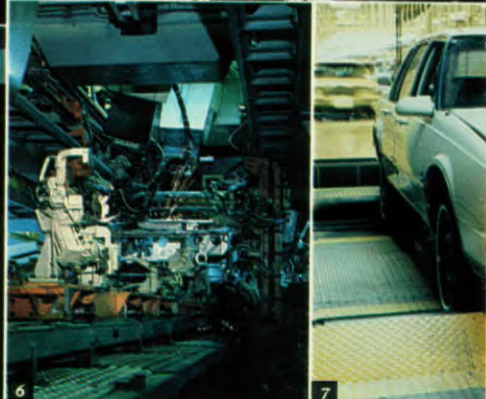

Automated Underbody System

The rear compartment, floor pan and motor compartment are welded together using 21 automatic welders, two welding presses and two robots. Then, 56 robots apply 167 spot welds to secure the side frame.



Robogate Body Framing

Here the precise dimensional interrelationship between the major assemblies is established. The body is automatically clamped into position for the framing operation which employs eight robots.

Cartrack II Roof Respot

Automatically locates and welds the roof onto the body to complete the body structure.

Total spot welds on the body done automatically through the entire process will approach almost 5,000.

It's people who determine Oldsmobile quality.

Robots and computers and optic scanners all have their place in today's technologically advanced age. Yet it is still trained and dedicated people—using their minds and their hands—who set the standards for excellence in the designing and building of Oldsmobiles.

New techniques to keep your Ninety-Eight Regency looking "showroom new!"

For instance, to fight off the effects of weather, the Ninety-Eight body is totally immersed in an ELPO bath of rust-resistant primers, thus forming a protective skin.

A new paint process was developed using multi-coat/high-gloss enamels. Nineteen numerically controlled robots apply two coats of base color and two coats of clear paint to the body to give

it a deep, lustrous "hand rubbed" look.

Even after the Ninety-Eight Regency is built, the quality pro-



Quality that was designed in is, in fact, built in.

cess is further heightened by the use of "Dynamic Vehicle Testing." Here Ninety-Eight Regency is computer-directed and monitored on dynamometer rolls. All critical functions are checked to make sure that everything meets Ninety-Eight Regency quality standards.

See, hear and feel Ninety-Eight Regency quality for yourself.

You can see Ninety-Eight Regency quality in the even, precise fit where trunk lid meets quarter panel, quarter panel meets door, door meets fender and fender meets hood.

You can hear Ninety-Eight Regency quality with its generous use of insulation and sound-deadening materials.

You can feel the quality every time you close its doors. Solid!

Quality is what makes an Olds worth owning.'

Quality is the essential character of the new 1985 Olds Ninety-Eight Regency. But, Oldsmobile's commitment to quality is also reflected in the Toronado, Delta 88 Royale, Cutlass Supreme, Cutlass Ciera, Olds Calais, Firenza and our Cruiser wagons.

Ransom E. Olds stated our goal best, "to build a carriage in as nearly a perfect manner as possible." And after 87 years, we're proud to be living up to those words.

Now we invite you to test drive, inspect, and completely check to your heart's desire the high levels of quality being built into every 1985 Oldsmobile.

Experience for yourself that special feeling of quality that makes any Olds you choose worth owning.

Computerized Dimensional Inspection

A contact probe inspects and verifies 30 pre-defined critical points on the underbody for precision and accuracy.

Cartrack I Underbody Respot

16 robots apply an additional 220 spot welds on each underbody to strengthen the body structure and ensure dimensional control.

There is a special feel
in an 

Delta 88 Luxury Sedan

*One great drive follows another.
And another. And another. Luxuriously.*



It would be right at home in any setting, on any road. This new Delta 88 Luxury Sedan is highlighted by impressive styling, opera lamps, tinted glass all around and gleaming new paint colors. Inside,

the full-foam comfort of the lavish velour seats is enhanced by the 6-way power control of the driver's seat, the power steering with Tilt-Wheel convenience, the power brakes and windows. All these and

many others are all standard. A smooth, powerful 5.0-liter V8 assures great drives wherever you choose to go. A 5.7-liter diesel V8 is available. (Not available in California.)



Delta 88 Luxury Sedan

*Luxury that's fit for
the First Family.*



Yours. After all, who deserves it more? Top-of-the-line luxury and comfort for six. The elegance of the rich velour seating (or available leather). The wall-to-wall plushness

of the cut-pile carpeting. Also, prepare to be pampered by a long list of standard features from automatic transmission to air conditioning to AM/FM stereo with dual rear

speakers. (Radio may be deleted for credit.) And power everything! Power steering, power brakes, power windows and door locks, power 6-way driver's seat. All standard.



Delta 88 Royale Brougham Sedan

*The kind of comfort your family will
appreciate over all the miles.*



You could buy it for style and luxury alone. But with an active family, you also need family-sized room and comfort. That's Delta 88 Royale Brougham. Those lavish velour seats are full-foam construction for rest-

ful relaxation over all the miles. Outside noise has been effectively muted with layers of insulation. And rough roads are smoother with efficient Pliacel shocks and computer-selected coil spring suspension.

20.8 cubic feet of trunk space easily accommodates luggage. Regency Brougham Sedan is practical and comfortable, yet stylish and lavish, too.



Delta 88 Royale Brougham Coupe

*Popular viewpoint: This is one family car
that didn't forget the family.*

Ask a family what it wants most in a family car and they'll likely answer "room and comfort with a lot of style, a lot of luxury." Delta 88 Royale Brougham replies with room for six with velour luxury. Plush carpeting underfoot. Lavish appointments all around. And the kind of quality and

dependability that keeps it on the road. And Royale Brougham won't forget your family at trade-in time with its traditionally high resale value. The style and luxury, the comfort and dependability really pay off.



Delta 88 Royale Sedan and Coupe

Great style and value keep its
popularity soaring.

Delta 88 owners keep coming back
year after year. They find they get a
lot of quality and value for the money.
Six-passenger room and comfort
with full-foam seats, velour interiors,
wall-to-wall cut-pile carpeting. A
lot of standard equipment, including
power steering, power brakes and

AM/FM stereo (which may be deleted
for credit). They also get a lot of
economy from a standard 3.8-liter
V6, and added performance from an
available 5.0-liter V8 with 4-speed
automatic overdrive transmission.
And traditionally high resale, too.



Delta 88 Royale

Facts, figures and features.

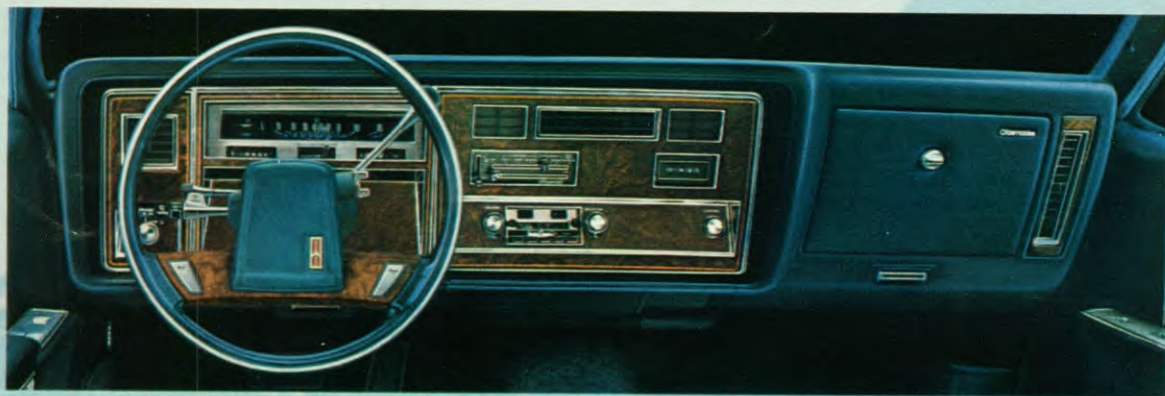

Like to get that special feel? Take the Delta 88 wheel!



Buckle up the little ones and don't forget to buckle up yourself.

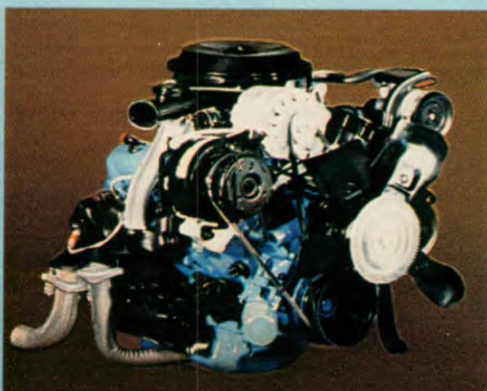

3.8-liter V6 is standard, 5.0-liter V8 available, 5.7-liter diesel V8 also available (except in California).



Opera lamps are standard equipment on Delta 88 LS. A touch of luxury.



Remote control side-view mirror is standard. Adjusts to different drivers.



Big, spacious trunk with 20.8 cubic feet to carry what a family needs.



The ride is smooth and quiet with computer-selected coil springs. It's easygoing all the way.



Deluxe Wheel Disc (left) std. on Royale and Brougham. Simulated Wire Wheel Disc with lock (center) std. on Delta 88 LS, avail. other Delta 88 models. Chrome-Styled Wheel (right) avail. on Royale and Brougham.

An inside look at Delta 88...

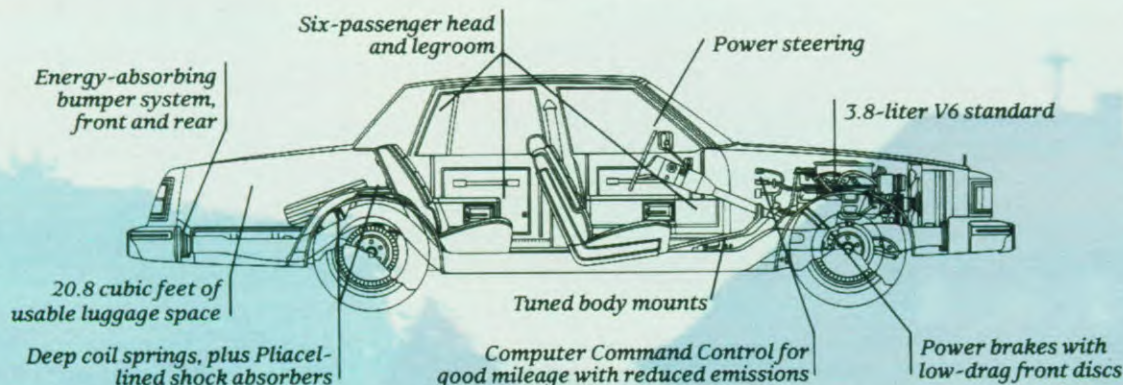

DELTA 88 STANDARD EQUIPMENT

Chassis and Body:

- Computer Command Control ■ Torque-Beam Frame Construction
- Computer-Selected Full Coil Spring Suspension, Front and Rear ■ Extensive Anti-Corrosion Treatments
- Low-Drag Power Front Disc Brakes ■ Power Steering ■ High-Energy Ignition System ■ Delcotron
- Compact Spare Tire ■ Side-Frame Jack
- Bumper Rub Strips, plus Integral Guards, Front and Rear ■ Recessed Windshield Wipers ■ Front-End Panel Stand-Up Ornament
- Rearview Mirror Remote Control, Driver Side ■ Roof Drip, Rocker Panel and Wheel-Opening Moldings
- Bright Deluxe Wheel Discs ■ Easy-Roll, High-Pressure Tires.

Interior:

- Full-Foam Seat Construction ■ Armrests, Front and Rear ■ Cut-Pile Carpeting, Wall to Wall with Carpeted Lower Door Panels ■ Simulated Butterfly Walnut Grain Instrument Panel Trim ■ Cigar Lighter
- Door-Actuated Courtesy Lamps ■ Deluxe Steering Wheel ■ Headlamp-On Warning Sound ■ Inside Day-Night Rearview Mirror ■ AM/FM Stereo Radio with Dual Rear Speakers and Fixed Mast Antenna (may be deleted for credit) ■ Interior Hood Lock Release
- Deluxe Seat Belts ■ Flo-Thru Ventilation.

STANDARD EQUIPMENT BY MODELS

Delta 88 Royale Brougham LS Sedan:

- Engine, 5.0-liter V8, 4-Barrel ■ Transmission, 4-Speed Automatic Overdrive ■ Four-Season Air Conditioner ■ Divided Bench Front Seat with 6-Way Power, Driver Side—Passenger Side, Manual ■ Tilt-Away Steering Wheel ■ Trip Odometer ■ Quartz Digital Clock ■ Power Side Windows ■ Soft-Ray Tinted Glass ■ Power Door Locks ■ Dual Outside Mirrors, Remote Control, Driver and Passenger Side
- Tungsten Halogen High-Beam Headlamps ■ Exterior Opera Lamps ■ Tires, P215/75R15 Steel-Belted Radial-Ply, White-Stripe—All-Season ■ Simulated Wire Wheel Discs with Locks... plus many other standard equipment items found on Royale Brougham models.

Delta 88 Royale Brougham Coupe and Sedan:

- Engine, 3.8-liter V6, 2-Barrel ■ Transmission, Automatic with Torque Converter Clutch and Column Shift ■ Pillar Opera Lamps (Coupe) ■ Body Side Moldings Color Coordinated to Lower Body (If Vinyl Rooftop is ordered, Moldings are Color Keyed to Rooftop Color) ■ Belt Reveal, Rocker Panel and Wheel-Opening Moldings ■ Bright Roof Drip Moldings ■ P205/75R15 Steel-Belted Radial-Ply, Blackwall Tires ■ Divided Front Seat with Individual Controls in Five Colors of Velour ■ Convenience Package of Lamps, Visor Vanity Mirror and Chime Tones.

Delta 88 Royale Coupe and Sedan:

- Engine, 3.8-liter V6, 2-Barrel ■ Transmission, Automatic with Torque Converter Clutch and Column Shift ■ Rocker Panel, Wheel-Opening and Body Side Moldings ■ Body Side Moldings Color Coordinated with Lower Body (If Vinyl Top is ordered, Moldings are Color Keyed to Top Color)
- P205/75R15 Steel-Belted Radial-Ply, Blackwall Tires ■ Custom Bench Front Seat with Center Armrest in Five Colors of Velour.

DELTA 88 AVAILABLE EQUIPMENT:

- 6-Way Power Seat Adjuster (Bench)
- 6-Way Power Seat Adjuster (Divided Seat, Driver and Passenger Sides)
- Divided Seat, with Individual Controls (Royale models)
- Reclining Seat Back—Passenger Side (Royale/Royale Brougham models)
- Soft-Ray Tinted Glass
- Power Door Locks
- Power Side Windows
- Power Trunk-Lid Lock Release
- Auxiliary Floor Mats, Front and Rear with Carpet inserts
- Deluxe Luggage Compartment Trim and Spare Tire Cover
- Door-Edge Guards
- Pulse Wiper System
- Electric Sliding Astrorooftop in Tinted Glass (Headroom is reduced with this option)
- Padded Vinyl Landau Roof Cover (Coupes); Full Vinyl Rooftop Cover (Sedans)
- Lower Body Side Moldings (Standard on LS Sedan)
- Belt Reveal Moldings (Standard on Royale Brougham)
- Custom Leather Trim, Medium Gray (LS Sedan models only)
- Firemist Paints, Autumn Red,

- Charcoal (LS Sedan models only)
- Four-Season or Tempmatic Air Conditioners
- Electric Rear Window Defogger
- Front Door Locks and Interior Illumination Package
- Color-Coordinated Remote and Manual Control Mirrors, Driver and Passenger Side
- Automatic Cruise Control with Resume and Acceleration Features
- Limited Slip Differential
- Engine Block Heater
- Diesel Engine Block and Fuel-Line Heater
- Tilt-Away or Tilt-and-Telescope Steering Wheel
- Simulated Wire Wheel Discs with Locks
- Chrome-Styled Wheels
- Convenience Group, includes Lamps, Visor Vanity Mirror and Chime Tones (Standard on Royale Brougham Models.)
- Combination Dome and Dual Lens Reading Lamp
- Electric Outside Mirrors, Driver and Passenger Side
- Cornering Lamps
- Tungsten Halogen Headlamps (High Beams)
- High-Capacity Battery
- Digital Quartz or Regular Clocks
- Trip Odometer
- Exterior Lamp Monitor, Front and Rear
- Instrument Panel Reminder Package
- Two-Tone Paint Scheme (Not Available on LS Sedan)
- Firm Ride and Handling Package
- Automatic Leveling System
- High-Capacity Engine Cooling Systems
- Radios and Tape Players (See page 35)
- Tires, P205/75R15 Steel-Belted Radial-Ply, White-Stripe
- Tires, P215/75R15 Steel-Belted Radial-Ply, White-Stripe
- Puncture-Sealing Tires
- Litter Container
- Body Side Accent Stripes
- Trailer Electrical Wiring Harness, 5-Wire

*See EPA mileage estimates in accompanying Fuel Economy Estimate Sheet.

Let's get it together... buckle up.

Custom Cruiser

"Roughing it" will have to wait till you get to the campsite.

This Olds Cruiser is so smooth and quiet, you'd think it was a fine sedan. Looks like it, too, with its handsome full-foam velour seating or glove-soft vinyl. So convenient, too, with its 3-way power tailgate. You can even order a fold-down third seat for eight-passenger capacity. Fold down

the second and third seat and there's 87.2 cubic feet of cargo space, plus an extra storage compartment with lock. 5.0-liter V8 with 4-speed automatic overdrive transmission is standard. 5.7-liter diesel V8 available (except in California).



Custom Cruiser

Facts, figures and specs.



3-way power tailgate is standard. You can also order a fold-down third seat.



Custom Cruiser provides 87.2 cubic feet of room with second seat folded down.



A roomy, under-floor storage compartment is standard.

An inside look at Custom Cruiser...

CUSTOM CRUISER STANDARD EQUIPMENT

Chassis and Body:

- Computer Command Control
- Computer-Selected Full Coil Spring Suspension, Front and Rear
- Firm Ride and Handling Package
- Extensive Anti-Corrosion Treatments
- Low-Drag Power Front Disc Brakes
- Power Steering
- High-Energy Ignition System
- Easy-Rolling, High-Pressure Tires
- Heavy-Duty Wheels
- Bumper Impact Strips with Integral Bumper Guards, Front and Rear
- 3-Way Tailgate Operation
- Side-Frame Jacking System
- Spare Tire Extractor.

Interior:

- Armrests, Front and Rear
- Ashtrays, Instrument Panel and Rear Seat
- Headlamp-On Warning
- Cigar Lighter
- Door-Pull Handles, Front and Rear
- Wall-to-Wall, Cut-Pile Carpeting, including Lower Door Panels and Cargo Area
- Hood Lock, Interior Operated
- Simulated Butterfly Walnut Grain Instrument Panel Trim
- Electric Rear Window Control on Instrument Panel
- Remote Control Outside Mirror, Driver Side
- Deluxe Steering Wheel
- AM/FM Stereo Radio with Dual Rear Speakers and Fixed Mast Antenna (may be deleted for credit)
- Rear Storage Compartment with Lock
- Deluxe Seat Belts
- Flo-Thru Ventilation.

CUSTOM CRUISER 2-SEAT WAGON

Additional Standard Equipment:

- Engine, 5.0-liter V8, 4-barrel
- 4-Speed Overdrive Automatic Transmission with Torque Converter Clutch
- Divided Bench Front Seat with Five Velour

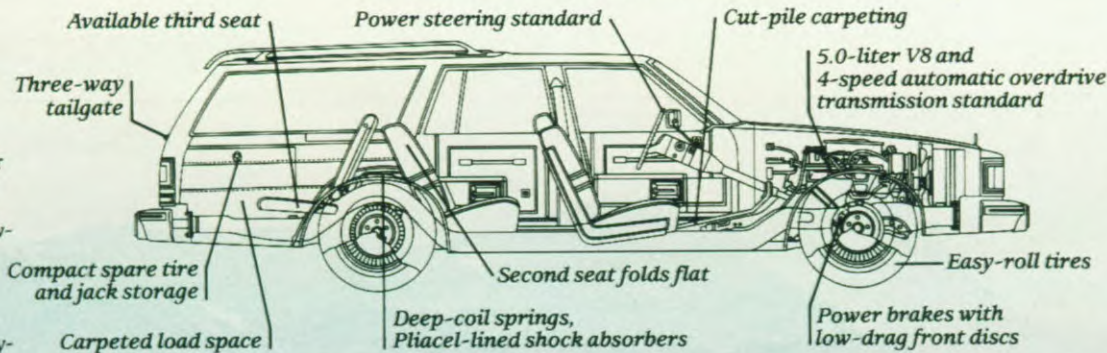

CUSTOM CRUISER POWER TEAMS	Liter/Type	5.7/V8 Diesel	Wheelbase (in.)	116.0	Legroom (front in.)	42.2
	Standard Transmission:*	4-Speed Overdrive Auto. with Torque Conv. Clutch	Cargo Cap. (cu. ft.)	87.2	Legroom (rear in.)	37.8
	Standard Engine:*	5.0/V8 Carburetion	Fuel Tank, Gas (gals.)	22.0	Headroom (front in.)	39.6
	Available Engine:*	4-Barrel	Fuel Tank, Diesel (gals.)	22.0	Headroom (rear in.)	39.3
			DIMENSIONS:		Shoulder Room (front in.)	60.6
			Overall Length (in.)	220.3	Shoulder Room (rear in.)	60.5

- and Two Doeskin Vinyl Trims to choose from
- P225/75R15 Steel-Belted Radial-Ply, Blackwall Tires
- Deluxe Wheel Discs

CUSTOM CRUISER AVAILABLE EQUIPMENT:

- 6-Way Power Seat Adjuster, Driver & Passenger Side
- Rear-Facing Third Seat
- Reclining Seat Back, Manual, Passenger Side
- Power Door Locks, including Tailgate
- Power Side Windows
- Body Side Accent Stripes
- Lower Body Side Moldings
- Body Side and Tailgate Simulated Walnut Grain Panels
- Auxiliary Floor Mats with Carpet Inserts, Front & Rear
- Rear Window Electric Defogger
- Rear Window Air Deflector—Rooftop Luggage Carrier required
- Pulse Wiper System

- Four-Season or Tempmatic Air Conditioner
- Soft-Ray Tinted Window Glass
- Body Side Moldings
- Combination Dome and Reading Lamp
- Front Door Lock and Interior Illumination Package
- Electrically Operated Outside Mirrors, Driver and Passenger Side
- Illuminated Visor Vanity Mirror, Passenger Side
- Limited Slip Differential
- Engine Block Heater
- Diesel Engine Block and

Fuel-Line Heater

- Automatic Cruise Control with Resume Feature
- Tilt-Away or Tilt-and-Telescope Steering Wheel
- Simulated Wire Wheel Discs with Locks
- Puncture-Sealing Tires
- Convenience Group, including Lamps, Visor Vanity Mirror and Chime Tones
- Color Coordinated, Outside Remote Control Mirrors—Driver and Passenger Side
- Tungsten Halogen Headlamps, High Beams
- Front Fender Cornering Lamps
- Digital Quartz or Regular Clocks
- Instrument Panel Gauge Cluster
- Trip Odometer
- Exterior Lamp Monitors, Front and Rear
- Rear Bumper Step, included in Rear Seat Package
- Rooftop Luggage Carrier, required with Rear Window Air Deflector (Optional as shown)
- Reminder Package, Indicators
- Automatic Leveling System
- High-Capacity Engine Cooling System
- Radios and Tape Players (See Page 35)
- Tires, P225/75R15 Steel-Belted Radial-Ply, White-Stripe
- High-Capacity Battery
- Trailer Electrical Wiring Harness

*See EPA mileage estimates in accompanying Fuel Economy Estimate Sheet.

Let's get it together... buckle up.

Toronado Brougham Coupe

*One-of-a-kind car in a
carbon-copy world.*



You'll never mistake it for anything else. Toronado is the personal luxury car that's as unique as the person who owns it. The style is distinctive. The performance, assured and con-

fident, combining front-wheel drive, automatic load leveling system, four-wheel independent suspension and 4-speed overdrive automatic transmission. 5.0-liter V8 is standard

and 5.7-liter diesel V8 available. (Diesel not available in California.) If you consider yourself a one-of-a-kind person, this is definitely your kind of car.



Toronado Caliente Coupe

*When you come down to earth,
it still makes your spirits soar.*



Owning a Toronado Caliente is an uplifting experience to mind and body. Those dashing Toronado lines are highlighted by a padded landau roof and stainless steel crown molding, gleaming side body and rocker

panel molding. Inside, Caliente comforts the body with custom leather in the seating areas, gives you a firm grip on things with a leather-wrapped steering wheel. Also standard are an electronic instrument cluster,

voice information reminder system, simulated wire wheel discs and other special features. In short, all the Toronado attributes with unique touches of its own.

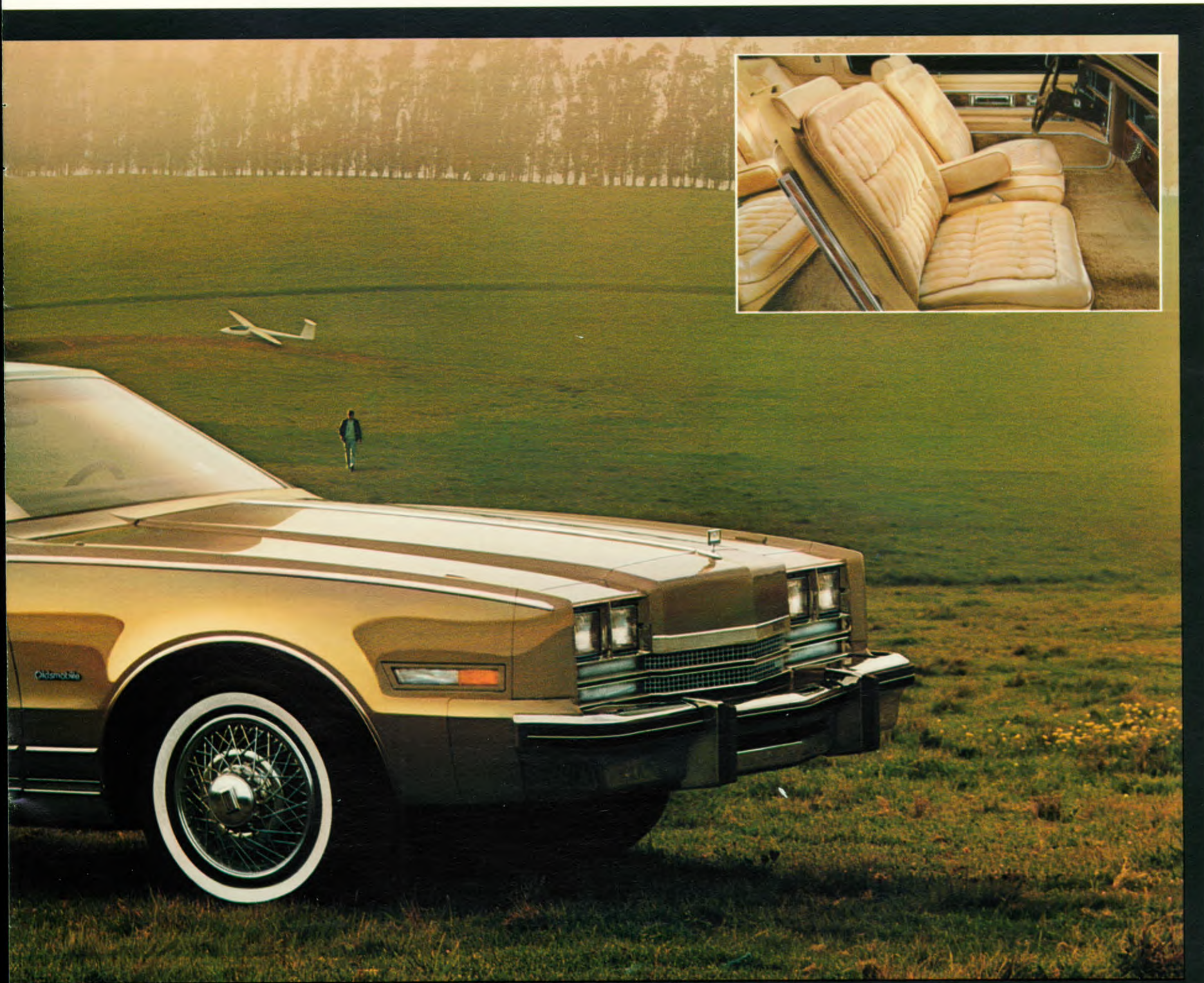

Toronado

Facts, figures and features.

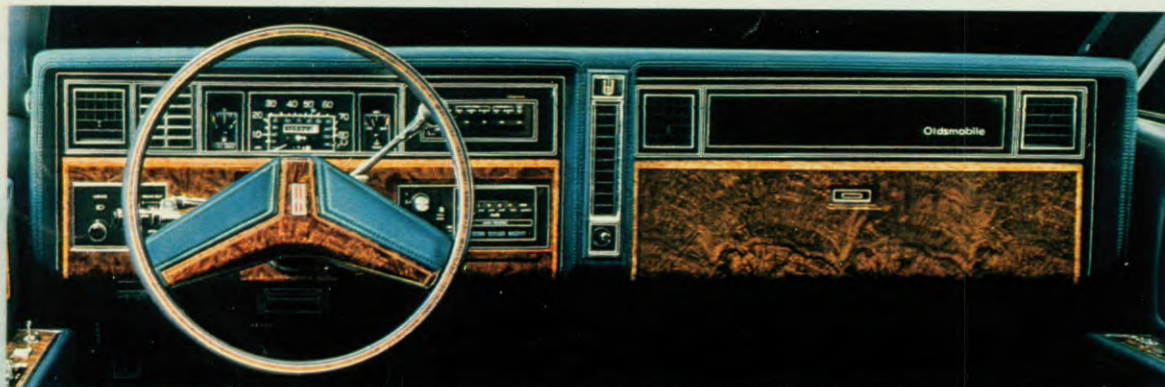

That special one-of-a-kind Toronado feel starts right here.



15.2 cubic feet of lined and carpeted trunk space.



Electronic instrument panel with digital read-outs is available. (Standard on Caliente.)
Voice information reminder system, available.



A "memory seat" that automatically presets the position most comfortable to the driver is available. Genuine leather in the seating areas is also available. It looks and feels so good.



Available electronic day-night mirror reduces glare automatically. So helpful in night driving.

Toronado's front-wheel drive pulls you confidently through snow, rain or sand.

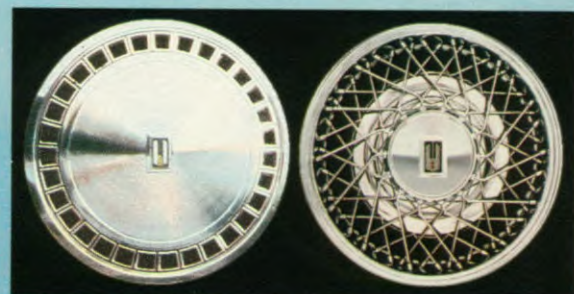

Deluxe Wheel Disc (left) is standard. Simulated Wire Wheel Disc with lock (right) is available. (Standard on Caliente.)



Tilt-Wheel Steering is standard on Toronado. Leather-wrapped steering wheel is standard on Caliente models.

An inside look at Toronado...

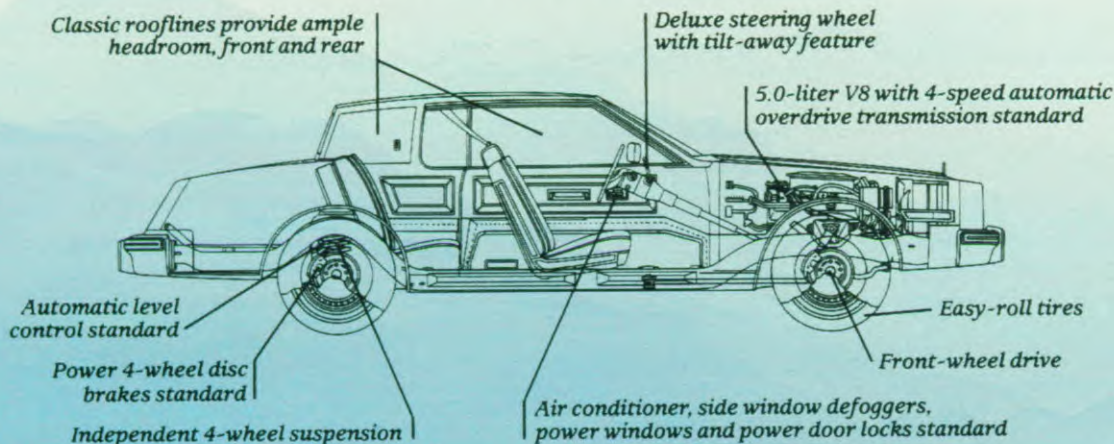

TORONADO BROUGHAM STANDARD EQUIPMENT

Chassis and Body:

- Computer Command Control
- High-Energy Ignition System
- Power Four-Wheel Disc Brakes
- Power Steering
- Front Torsion Bar and Rear Coil Suspension
- Torque-Beam Full Frame Construction
- Side-Frame Jacking System
- Compact Spare Tire and Wheel
- Space-Efficient Trunk with Deluxe Trim and Spare Tire Cover
- Bumper Impact Strips with Integral Bumper Guards, Front and Rear
- Extensive Sound Deadeners
- Anti-Corrosion Treatments
- Automatic Level Control
- Tungsten Halogen Headlamps (High Beams)
- Front Fender Cornering Lamps
- Four-Wheel Independent Suspension
- Bright Roof Drip, Rocker Panel and Wheel-Opening Moldings
- Deluxe Bright Wheel Discs
- Delcotron

Interior:

- Four-Season Air Conditioner
- Front and Rear Seat Center Armrests
- Pulse Tone Headlamp-On Warning
- ETR™ AM/FM Stereo Push-button Radio with Digital Quartz Clock, 2 Rear Speakers, plus Power Front Fender Antenna (may be deleted for credit)
- Convenience Group Lamps, Visor Vanity Mirror
- Cruise Control with Resume and Acceleration Feature
- Side Window Defogger
- Power Door Locks
- Power Side Windows
- Interior Operated Hood Lock Release
- Instrument Panel Temperature Gage and Trip Odometer
- Soft-Ray Tinted Glass
- Simulated Butterfly Walnut-Grained Instrument Panel Trim
- Full-Foam Seat Construction
- Divided Front Seats with Individual Controls
- 6-Way Power Seat Adjuster, Driver Side
- Deluxe Steering Wheel with Tilt-Away Features
- Deluxe Seat Belts, Color

TORONADO BROUGHAM POWER TEAMS	Available Engines:*	Wheelbase (in.) 114.0	Legroom
Standard Engine:*	Liter/Type 5.7/V8 Diesel	Luggage Capacity (cu. ft.) 15.2	front (in.) 42.8
Liter/Type 5.0/V8	Standard Transmission:*	Fuel Tank Capacity	rear (in.) 39.2
Carburetion 4-Barrel	4-Speed Overdrive Automatic	Gas (gals.) 21.1	Shoulder Room
	DIMENSIONS:	Diesel (gals.) 22.8	front (in.) 56.6
	Overall Length (in.) 206.0	Headroom, front (in.) 37.9	rear (in.) 55.9
		Headroom, rear (in.) 37.9	

- Keyed to Individual Interiors
 - Flo-Thru Ventilation
 - Fluidic Action Windshield Washers
 - Dual Front and Rear Ashtrays
 - Cigar Lighter
 - Door-Pull Handles
 - Wall-to-Wall, Cut-Pile Carpeting with Carpeted Lower Door Panels
 - Courtesy/Warning Lamps on Doors
 - Instrument Panel, Glove Box, Dome Courtesy Lamps
 - Inside Day-Night Mirror
- Additional Standard Equipment:**
- Engine, 5.0-liter V8, 4-Barrel
 - 4-Speed Overdrive Automatic Transmission with Torque Converter Clutch
 - P205/75R15 Steel-Belted Radial-Ply, White-Stripe Tires
 - Outside Rearview Mirrors with Remote Control on Driver and Passenger Side

TORONADO AVAILABLE EQUIPMENT:

- Automatic Inside Day-Night Mirror
- Voice Information Reminder System
- Custom Leather/Shearling Trim, Chamois Leather/Shearling
- Caliente Trim Package
- 6-Way Power Seat Adjuster (Passenger Side)
- 6-Way Power Seat Adjuster with 2-Position Memory Feature (Driver Side)
- Reclining Seat Back, Manual (Passenger Side)

- Reclining Seat Back, Manual (Driver Side)
- Reclining Seat Back, Power (Passenger Side)
- Automatic Power Door Locks
- Power Trunk-Lid Lock Release
- Auxiliary Floor Mats with Carpet Inserts—Front and Rear
- Luggage Compartment Floor Mat
- Body Side Moldings—Color coordinated with Lower Body or Vinyl Rooftop Cover if ordered
- Door-Edge Moldings
- Pulse Wiper System
- Electric Sliding Glass Astrorof (Headroom is reduced with this option)
- Landau-Padded Vinyl Rooftop Covering
- Electric Rear Window Defogger
- Tempmatic Air Conditioner
- Exterior Sail Panel Opera Lamps
- Dome and Dual Lens Reading Lamp Combination

- Rear Seat Reading Lamps, Sail Panel Mounted
- Illumination Package for Front Door Locks and Interior
- Electrically Operated Outside Rearview Mirrors
- Illuminated Visor Vanity Mirror (Passenger Side)
- Body Side Accent Stripes
- Engine Block Heater
- Diesel Engine Block and Fuel-Line Heater
- Leather-Wrapped Steering Wheel
- Tilt-and-Telescope Steering Wheel
- Simulated Wire Wheel Discs with Locks
- Puncture-Sealing, White-Stripe Tires
- Twilight Sentinel Light Control
- High-Capacity Battery
- Theft-Deterrent System
- Exterior Lamp Monitors, Front and Rear
- Special Firemist Paints in Autumn Red, Charcoal, Champagne, Saddle Tan
- Custom Leather Trim in Seating Areas, in Medium Gray, Claret, Medium Beige
- Reminder Package—Includes indicators for Low Fuel, Low Washer Fluid, High-Low Voltage, High-Engine Temperature and Low Coolant
- Two-Tone Paint Scheme
- Firm Ride and Handling Package—Includes Higher Rate Front Torsion Bars and Rear Springs, Firm Ride Front and Rear Shock Absorbers, Larger Front Stabilizer Bar, Rear Stabilizer Bar and Special Steering Gear (Tires QHK required)
- High-Capacity Cooling Systems
- Trailer Electrical Wiring Harness
- Radios and Tape Players (See Page 35)
- P225/70R15 Steel-Belted Radial-Ply, White-Stripe Tires (Available and required with Firm Ride and Handling Package)
- Electronic Instrument Panel Cluster

*See EPA mileage estimates in accompanying Fuel Economy Estimate Sheet.

Let's get it together... buckle up.

Get That Special Feel

Select from these special Oldsmobile options and accessories.



Tilt-Wheel Steering. Adjusts to six different driving positions. Standard on Delta 88 Luxury Sedan, Ninety-Eight models, Toronado.



High-level stoplight available on Ninety-Eight. Lights up with tail lamp when you brake.



Electric sliding Astrorooftop gives you a fresh outlook on the world.



Cornering lamps help signal your intentions to drivers and pedestrians. Standard on Regency Brougham and Toronado.



Illuminated visor/vanity mirror. Lights up when cover is opened. Most convenient.



Four-Season air conditioner standard on Delta 88 Luxury Sedan and Toronado.



Delco-GM/Bose music system is the finest auto sound system available today.

Important: A word about this catalog. We have tried to make this catalog as comprehensive and factual as possible, and we hope you find it helpful. However, since the time of printing, some of the information you will find here may have been updated. Also, some of the equipment shown or described throughout this Olds catalog is available at extra cost. Your dealer has details and, before ordering, you should ask him to bring you up-to-date. The right is reserved to make changes at any time, without notice, in prices, colors, materials, equipment, specifications and models. Check with your Olds dealer for

complete information.

A word about engines: Oldsmobiles are equipped with engines produced at facilities operated by GM car groups, subsidiaries or affiliated companies worldwide. Please refer to the "Fuel Economy Estimate Sheet" provided to your dealer for engine source and EPA mileage estimates.

A word about assembly, components and optional equipment in these Oldsmobile products: The Oldsmobiles described in this catalog are assembled at facilities operated by General Motors or GM of

Canada. These vehicles incorporate thousands of different components produced by car groups or various component divisions of GM and by various suppliers to GM. From time to time during the manufacturing process, it may be necessary, in order to meet public demand for particular vehicles or equipment, or to meet federally mandated emissions, safety and fuel economy requirements, or for other reasons, to produce Oldsmobile products with different components or differently sourced components than initially scheduled. All such components have been approved for use in Oldsmobile products and will pro-

vide the quality performance associated with the Oldsmobile name.

With respect to extra-cost optional equipment, make certain you specify the type of equipment you desire on your vehicle when ordering it from your dealer. Some options may be unavailable when your car is built. Your dealer receives advice regarding current availability of options. You may ask the dealer for this information. GM also requests the dealer to advise you if the option you ordered is unavailable. We suggest that you verify that your car included the optional equipment you ordered or if there are changes, that they are acceptable to you.

The 1985 Oldsmobiles:
 Toronado Brougham Coupe
 Ninety-Eight Regency Brougham Sedan
 Ninety-Eight Regency Brougham Coupe
 Ninety-Eight Regency Sedan
 Ninety-Eight Regency Coupe
 Custom Cruiser
 Delta 88 Luxury Sedan
 Delta 88 Royale Brougham Sedan

Delta 88 Royale Brougham Coupe
 Delta 88 Royale Sedan
 Delta 88 Royale Coupe
 Cutlass Salon Coupe
 Cutlass Supreme Brougham Coupe
 Cutlass Supreme Brougham Sedan
 Cutlass Supreme Coupe
 Cutlass Supreme Sedan
 Cutlass Cruiser

Cutlass Ciera Brougham Sedan
 Cutlass Ciera Brougham Coupe
 Cutlass Ciera LS Sedan
 Cutlass Ciera LS Coupe
 Calais Supreme Coupe
 Calais Coupe
 Firenza SX Coupe
 Firenza LX Sedan
 Firenza Coupe

Firenza Sedan
 Firenza LX Cruiser
 Firenza Cruiser

There is a special feel
 in an



Oldsmobile



Rear window defogger. Electric filaments in the glass defog the window quickly and silently.

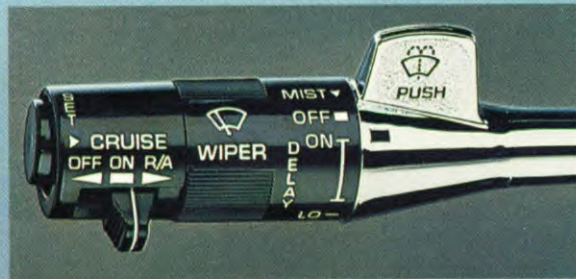

Cruise Control with "Accel" feature. Lets you accelerate to desired speed and hold it. Anyone who's ever taken a long trip wouldn't be without it. Standard on Toronado.

DELCO-GM SOUND SPECIALIST RADIOS	Cruiser	Delta 88	Regency	Toronado
Delco-GM Bose Music System			A	A
ETR AM/FM Stereo/Seek & Scan and Auto-Reverse Cassette with Search & Repeat/Equalizer & Clock			A*	A*
ETR AM/FM Stereo/Seek & Scan and Auto-Reverse Cassette with Clock/Noise Reduction	A	A*	A*	A*
ETR AM/FM Stereo with Clock			S	S
AM/FM Stereo and Cassette	A	A*		
40-channel Universal Citizens Band			A	
AM/FM Stereo	S	S		

S=Standard, may be deleted for credit. A=Available. *Includes extended range speakers.



ETR AM/FM stereo, cassette player/equalizer/clock available on Toronado, Ninety-Eight.



ETR AM/FM stereo with cassette player and digital clock. Includes electronically tuned receiver.



**Protection
 Plan**

GM's Protection Plan offers service protection in addition to that provided by GM's New Vehicle Limited Warranty. Ask your dealer for details. Coverage available only in U.S.A. and Canada. Why drive without it?

Standard occupant-protection features: Manual lap/shoulder belts for driver and right front passenger (driver side includes visual and audible warning system) • Manual lap belts at each rear seat position • Energy-absorbing steering column • Energy-absorbing instrument panel • Energy-absorbing tops, front seats • Laminated safety windshield glass and tempered safety side and rear window glass • Safety interlocking door latches • Passenger-guard inside door lock handles • Inertia-locking, folding front seat backs • Safety armrests • Safety strength seat adjustments • Head restraints, driver & right front

passenger (adjustable/integral).

Standard accident-avoidance features: Side marker lights and reflectors • Parking lamps that illuminate with headlamps • Four-way hazard warning flasher • Back-up lights • Directional signal control • Windshield defroster, washer and dual speed wipers • Inside rearview mirror with vinyl-bonded glass • Outside left rearview mirror ("right" also standard on some models) • Brake system with dual master cylinder and warning light • Starter safety switch • Dual action hood latch system. Low-glare finish on instrument panel top, inside

windshield moldings, wiper arms/blades, metallic steering wheel surfaces • Illuminated heater and defroster controls • Illuminated windshield wiper and washer controls • Tires with built-in tread-wear indicators.

Standard built-in, anti-theft features: Audible reminder for ignition key removal • Anti-theft steering column lock • Visible vehicle identification number.

Every new 1985 Oldsmobile delivered by an Oldsmobile dealer in the United States comes with a one year, \$10,000 seat belt insurance certificate from MIC General Insurance

Corporation at no additional charge. \$10,000 will be paid to the estate of any occupant who suffers fatal injuries as a result of an accident involving that vehicle while wearing a GM seat belt. Buckle up every time you drive.

A word about updated service information: Oldsmobile regularly sends its dealers useful service bulletins about Oldsmobile products. Oldsmobile monitors product performance in the field. We then prepare bulletins for servicing our products better. Now you can get these bulletins, too. Ask your dealer. To get ordering information, call toll free 1-800-551-4123.

