

SIERRA

2001

**A LESSON IN TRUCKS**  
from the people with 99 years  
of pure truck experience.

2001

**GMC**

SIERRA

# SIERRA

For nearly 100 years, GMC has focused on trucks, and nothing but trucks. In that time we've learned what you want in your vehicle — honest performance in which form follows function. We've learned that every innovation must be there for a purpose, grounded in true truck capabilities and usefulness. And when it comes to a full-size pickup, we've learned the value of a truck that offers unsurpassed control. The result of these lessons learned? The Sierra for 2001, with power, strength and refinement that we believe could only have come from GMC.

## CONTENTS

2	MODEL LINE	16	TOWING & HAULING	30	SAFETY
6	POWERTRAIN	22	INTERIOR	34	ACCESSORIES
12	RIDE & HANDLING	28	RELIABILITY	36	SPECIFICATIONS

FOR MORE INFORMATION ON SIERRA'S PRICING AND COLOR SELECTION, 360-DEGREE VIEWS OF THE INTERIORS, COMPETITIVE COMPARISONS AND MORE, VISIT GMC'S EASY-TO-USE WEBSITE.  
[gmc.com/sierra](http://gmc.com/sierra)



SIERRA 1500 SLT EXTENDED CAB  
in Fire Red with 4WD and  
other available equipment.

# LESSON ONE: CHOOSE THE RIGHT TOOL FOR THE JOB.

**WE KNOW THAT YOU CAN'T CHOOSE THE RIGHT TRUCK IF YOU DON'T HAVE A CHOICE. THAT'S WHY THE 2001 LINE OF GMC TRUCKS OFFERS AN EXCEPTIONAL VARIETY OF MODELS.**

Whether you're looking for 2WD or 4WD, Regular, Extended or Crew Cab, gasoline engine or diesel, GMC has a truck to fit your needs. In fact, the trucks pictured here are only a portion of our lineup. On the following pages, we'll introduce you to the full breadth of what we think is the most diverse and capable line of full-size pickups available today. See pages 36-47 for a full description of available models and configurations.

**SPORT SPECIAL EDITION** Available in 2WD 1500 Series models, the Sport Special Edition sets the standard in sport styling.

**1500 SERIES** To meet both passenger and cargo-carrying needs, 1500 Series trucks are available in 2WD or 4WD with Regular or Extended Cabs.

**2500 SERIES** 2500 Series trucks are available in a 2WD Regular Cab or a 4WD Extended Cab configuration.



**SPORT SPECIAL EDITION**



**1500 EXTENDED CAB**



**2500 EXTENDED CAB**

## LESSON TWO: YOU CAN NEVER HAVE TOO MUCH TRUCK.

**BIG JOBS CALL FOR POWERFUL TRUCKS. AND THAT'S WHERE GMC'S LINE OF HEAVY-DUTY TRUCKS COMES IN. FOR 2001, GMC INTRODUCES AN ALL-NEW LINE OF THREE-QUARTER AND ONE-TON PICKUPS.**

With a variety of all-new powertrains, the 2001 line of heavy-duty pickups offers more powerful engines, higher GVW ratings and GCW ratings and higher towing ratings than any other comparable line of full-size pickups or Chassis Cabs in their class.<sup>1</sup> Whether you're looking for a Regular, Extended or Crew Cab, gasoline or turbo-charged diesel engine, 2WD or 4WD, short box, long box or Chassis Cab, or dual rear-wheel model, there's a GMC heavy-duty truck built to exceed your needs.

**HEAVY-DUTY 2500HD SERIES** 2500HD Series trucks are built to handle the most demanding jobs. Both 2WD and 4WD models have the highest GVW rating and GCW rating in their class,<sup>1</sup> and come with Regular, Extended or Crew Cabs.

**HEAVY-DUTY 3500 SERIES** 3500 Series trucks also provide the highest GVW rating and GCW rating in their class.<sup>1</sup> 3500 Series trucks come standard with dual rear wheels and with Regular, Extended or Crew Cabs.



**HEAVY-DUTY 2500HD CREW CAB**



**HEAVY-DUTY 3500 CREW CAB**

All-new Sierras are also available in Chassis Cab configurations up to 12,000 lbs GVWR.<sup>2</sup> Classic Sierras are available as Chassis Cabs up to 15,000 lbs GVWR.<sup>2</sup> Please refer to the GMC commercial catalog for complete details.

<sup>1</sup>Excludes other GM vehicles. Based on 8,600 lbs through 12,000 lbs GVWR. <sup>2</sup>When properly equipped; includes weight of vehicle, passengers, cargo and equipment.



SIERRA HEAVY-DUTY  
2500HD SLT CREW CAB  
in Pewter with 4WD and  
other available equipment.



SIERRA HEAVY-DUTY  
3500 SLT EXTENDED CAB  
in Summit White with 2WD  
and other available equipment.

**VORTEC**  
**4.3L V6**

262 cubic inches  
200 hp @ 4600 rpm  
260 lb-ft torque @ 2800 rpm

**VORTEC**  
**4.8L V8**

293 cubic inches  
270 hp @ 5200 rpm  
285 lb-ft torque @ 4000 rpm

**VORTEC**  
**5.3L V8**

325 cubic inches  
285 hp @ 5200 rpm  
325 lb-ft torque @ 4000 rpm

## LESSON THREE: IT'S NOT JUST THE HORSEPOWER, IT'S THE TORQUE.

**CHECK OUT THE FIGURES ABOVE. THE FACTS ARE THESE:  
THE ENGINES IN OUR 2001 SIERRA ARE REMARKABLE NOT ONLY FOR  
THEIR HORSEPOWER, BUT FOR THEIR TORQUE. THROUGHOUT THE RPM  
RANGE, THESE ENGINES PULL, GIVING YOU POWER ON DEMAND.**

What do you want from an engine? If you're a typical GMC customer, you want it all: power, economy, reliability, durability and refinement.

1500 Series trucks come standard with the 4.3L V6 or 4.8L V8, depending on the cab and box configuration you choose and whether you opt for 2WD or 4WD. For even more power, the 5.3L V8 is available. 2500 Series pickups come with the extraordinary 300 hp Vortec 6.0L V8.

Want more proof powertrains are the heart and soul of the Sierra? Consider this list of technical features found on the Vortec V8s:

- A** Composite intake manifold helps keep the intake air cool for more power.
- B** Coil-over-plug ignition produces a reliable, efficient spark for up to 100,000 miles.<sup>1</sup>
- C** An inline, or planar, valve train helps reduce stress, allows use of lighter, quieter components.
- D** Fuel-injector spray aimed precisely at the intake valve optimizes mix and combustion.

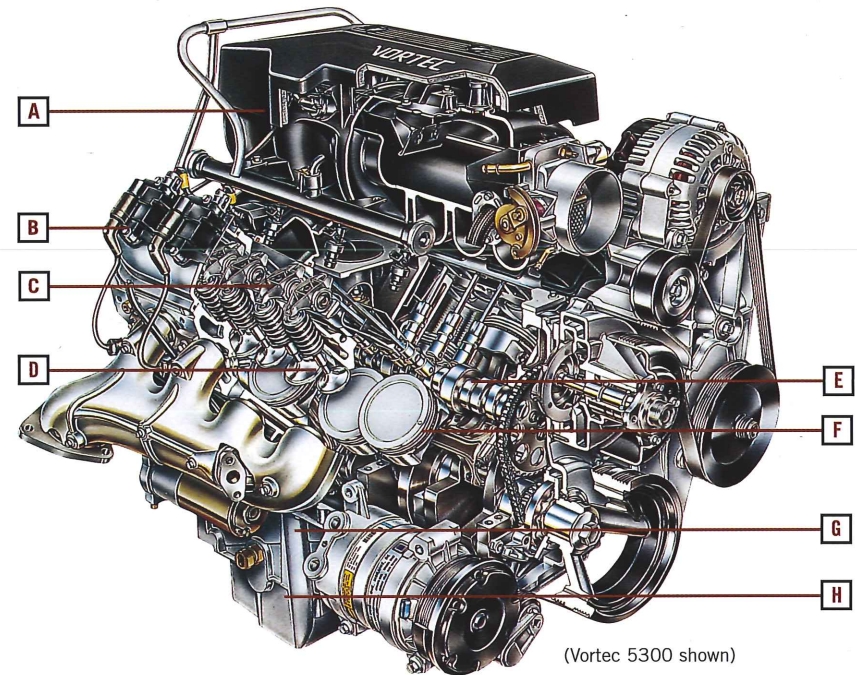

(Vortec 5300 shown)

- E** Billet steel camshaft design increases strength for quiet operation.
- F** Pistons and rods are strong yet light, so the engine can run at high rpm and produce power.
- G** Deep-skirt cast-iron block with cross-bolted 6-bolt main bearing caps increases strength, durability.
- H** Single-plane oil pan seals better; Teflon™ front and rear main seals last 50% longer than before.

### MORE USABLE TORQUE



The Vortec V8 engines reach torque peak at 4000 rpm or less. But they produce more than 90% of peak from around 1200 rpm to nearly 5000 rpm – essential for a truck to provide outstanding towing and hauling.

### SUBMARINE TECHNOLOGY



The cooling fan of the Vortec V8 engines was designed with the same technology used to help quiet the propellers of the most advanced nuclear submarines. The design helps the fan draw less power, reducing fan noise.

**VORTEC  
6.0L V8**

364 cubic inches  
300 hp @ 4400 rpm  
360 lb-ft torque @ 4000 rpm

**VORTEC  
8.1L V8**

496 cubic inches  
340 hp @ 4200 rpm  
455 lb-ft torque @ 3200 rpm

**DURAMAX  
6.6L TURBO DIESEL V8**

402 cubic inches  
300 hp @ 3100 rpm  
520 lb-ft torque @ 1800 rpm

**THE ENGINES IN HEAVY-DUTY SIERRAS ARE NOTHING SHORT OF EXTRAORDINARY. THE VORTEC 6.0-LITER V8—THE MOST POWERFUL STANDARD ENGINE IN ITS CLASS<sup>1</sup>—COMES STANDARD IN ALL MODELS. THE VORTEC 8.1-LITER V8 AND DURAMAX™ TURBO DIESEL ARE BOTH AVAILABLE IN ALL MODELS.**

Sierra heavy-duty truck engines were designed with your needs in mind. Each has a flat torque curve with abundant torque at low rpm, ideal for towing and hauling. Each provides up to 12,000 lb trailer-tow ratings.<sup>2</sup> And each has enhanced fuel efficiency.

With that kind of engineering, it should come as no surprise that Sierra's engines have more horsepower and torque than the competition's line of engines.

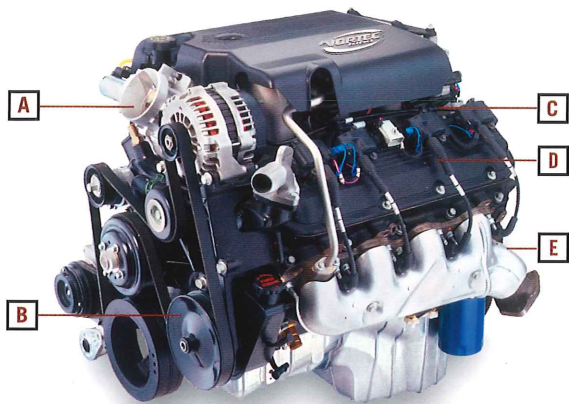

Vortec 8.1 liter V8 shown

- A** New Electronic Throttle Control system optimizes driveability and fuel economy and reduces emissions.
- B** Internally balanced crankshaft reduces stress for enhanced durability.
- C** Balanced cooling system distributes equal amounts of coolant to both banks of the cylinder case for more efficient cooling.
- D** Coil-near-plug ignition system produces a reliable, efficient spark.
- E** New extended-tip spark plugs improve idle smoothness.

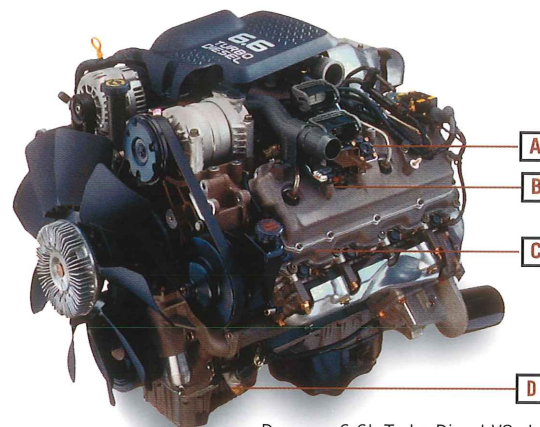

Duramax 6.6L Turbo Diesel V8 shown

- A** Aluminum high-swirl cylinder heads with four-valve-per-cylinder design optimizes breathing for good combustion.
- B** Intelligent designs such as a center-mounted turbocharger and oil-spray piston cooling contribute to enhanced durability.
- C** Use of aluminum for key components such as cylinder heads results in lightweight design and improved fuel economy.
- D** Powerful standard block heater has a 1,000-watt capacity for quicker startups in extremely cold weather.

**POWER, DURABILITY, FUEL EFFICIENCY — THE ALL-NEW DURAMAX TURBO DIESEL HAS GOT IT ALL. IT FEATURES A DIRECT-INJECTION OVERHEAD-VALVE DESIGN WITH FOUR VALVES PER CYLINDER FOR MAXIMUM PERFORMANCE AT ANY RPM.**

How advanced can a diesel engine be? The Duramax V8 is engineered to set the standard in turbo diesels.

It has a nitride crankshaft, induction-hardened block, and valve seat inserts for enhanced durability. A deep-skirt design and induction-hardened block with a single-piece cast aluminum crankcase combine to control vibration for an exceptionally smooth, quiet operation.

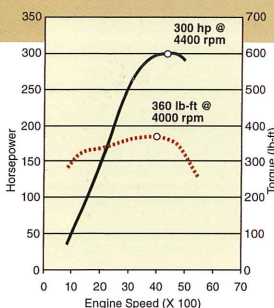

**VORTEC 6.0L V8**

Improvements to the Vortec 6000 engine have resulted in a boost in torque of 5 lb-ft over the previous-generation engine.

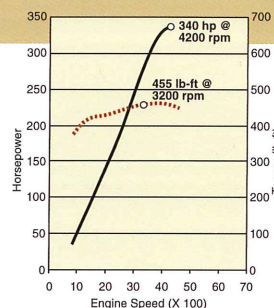

**VORTEC 8.1L V8**

The all-new Vortec 8100 produces 340 hp and 455 lb-ft of torque — more horsepower and torque than the competition's V10s.

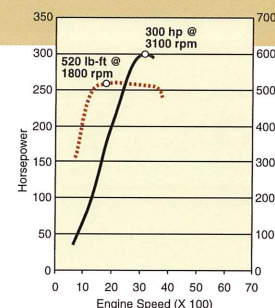

**DURAMAX 6.6L TURBO DIESEL V8**

Producing 300 horsepower and an astounding 520 lb-ft of torque at 1800 rpm, the all-new Duramax 6.6-liter turbo diesel V8 provides exceptional hauling and towing capabilities.

<sup>1</sup>Excludes other GM vehicles. Based on 8,600 lbs through 12,000 lbs GVWR. <sup>2</sup>Maximum trailer ratings are calculated assuming a standard equipped base vehicle plus driver. See the GMC Trailing Guide for details.



SIERRA HEAVY-DUTY  
2500HD SLT CREW CAB  
in Polo Green with 4WD  
and other available equipment.

**SIERRA LETS YOU CHOOSE FROM A VARIETY OF AUTOMATIC AND MANUAL TRANSMISSIONS. EVERY ONE IS ENGINEERED FOR SMOOTH SHIFTING, QUIET OPERATION AND LONG-LASTING DURABILITY.**

Sierra 1500 and 2500 Series trucks come standard with a smooth-shifting five-speed manual transmission, or an optional four-speed automatic.

Sierra heavy-duty trucks with the Vortec 6.0-liter V8 come standard with a five-speed manual transmission. A 4L80-E four-speed automatic transmission is optional. It uses a high-extension torque converter designed to provide exceptionally smooth power transition between gearshifts.

Heavy-duty trucks with either the Vortec 8.1-liter V8 or Duramax 6.6-liter turbo diesel come standard with an all-new, fully synchronized ZF S6-650 six-speed manual transmission. An all-new Allison 1000 Series five-speed automatic is optional.

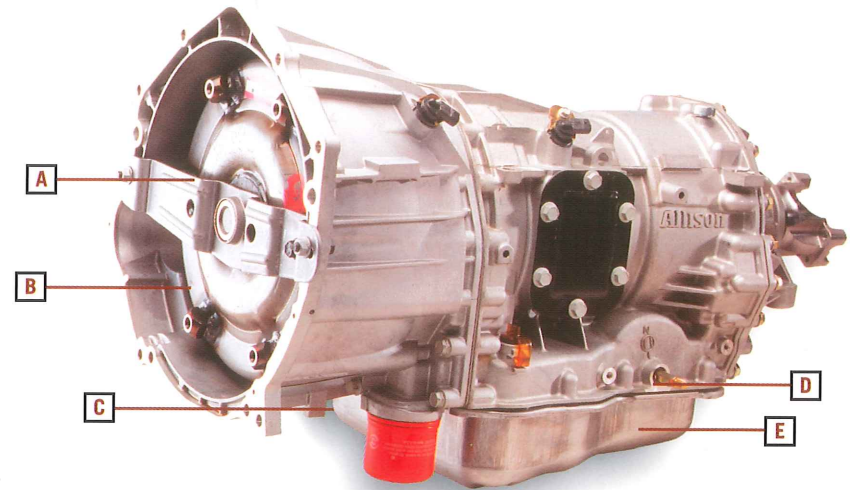

Allison 1000 Series Five-speed Automatic Transmission

- A** When in drive, the transmission control module automatically selects the gear for each drive range and engages the torque converter lock-up clutch.
- B** Clutches are hydraulically actuated and spring released, with automatic compensation for wear. As they wear they adjust and maintain enough pressure to continue providing shift quality.
- C** Helical-type gears are used for a better gear profile and quieter operation.
- D** Narrow gear ratio splits provide more torque in low gears.
- E** Large, strong gears and clutches and robust clutch material enhance durability.

**VORTEC 4.3L V6, 4.8L V8, 5.3L V8 AND 6.0L V8**

**Standard Transmission** Five-speed Manual

**Optional Transmission** Four-speed Automatic

**VORTEC 8.1L V8 AND DURAMAX 6.6L TURBO DIESEL**

**Standard Transmission** Six-speed Manual

**Optional Transmission** Allison Five-speed Automatic



SIERRA 2500 SLE EXTENDED CAB  
in two-tone Fire Red over  
Pewter with 4WD and other  
available equipment.



Sierra's cab is 60 percent stiffer than its predecessor.<sup>1</sup> Its highly rigid architecture (tested to 23Hz) allows less flex, for fewer squeaks and rattles.

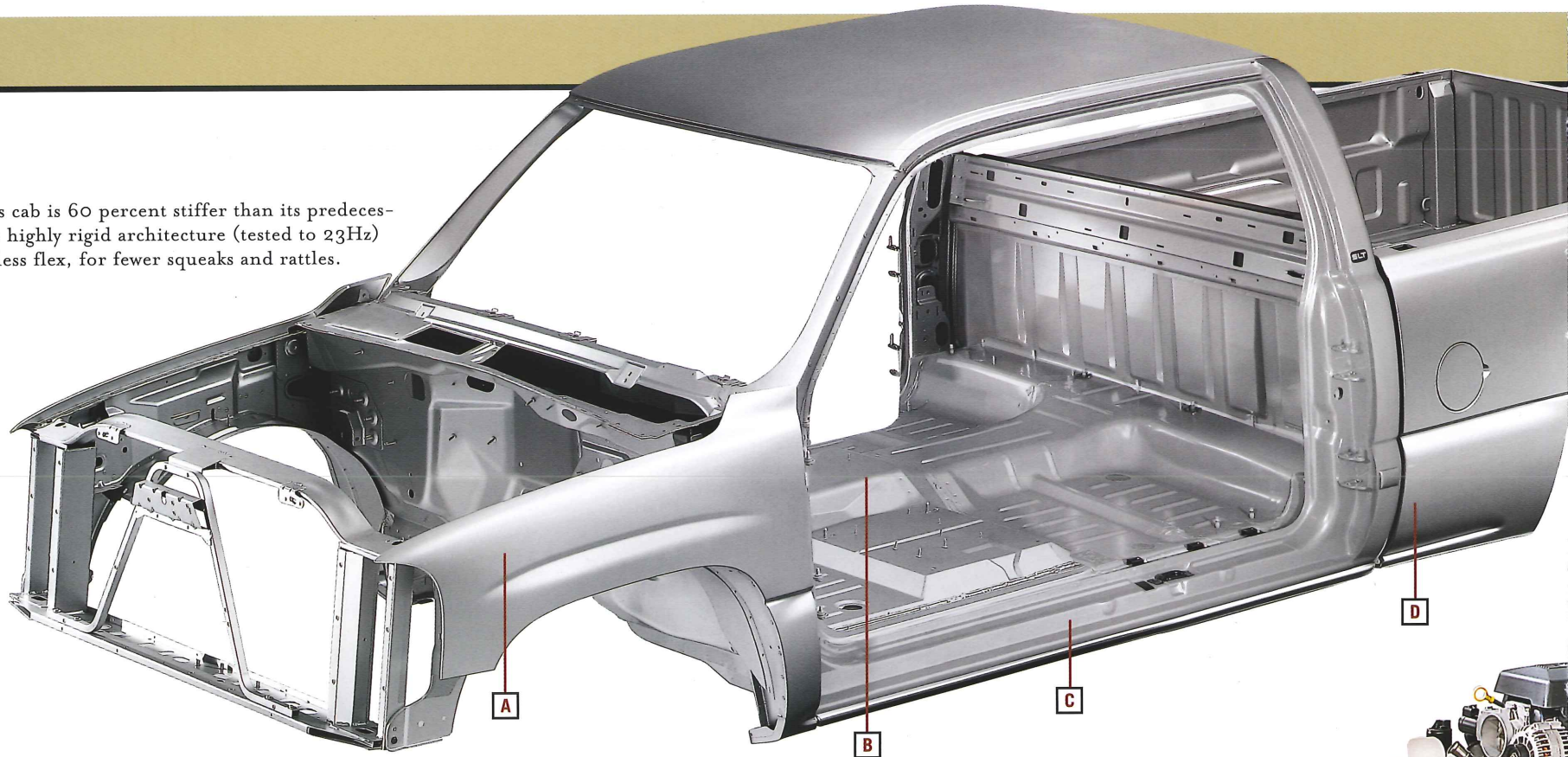

## LESSON FOUR: STRENGTH COMES FROM WITHIN.

**THE SIERRA 1500 AND 2500 SERIES FRAME IS STRONGER, STIFFER AND LIGHTER THAN ITS PREDECESSOR!** The three-piece modular design provides a strong platform that stands up to rugged use, yet helps achieve Sierra's smooth, quiet ride. The front, middle and rear frame rails are manufactured independently, using optimum materials and processes for each, to achieve greater strength without adding weight. After all, a pickup truck should haul the load, not be the load.

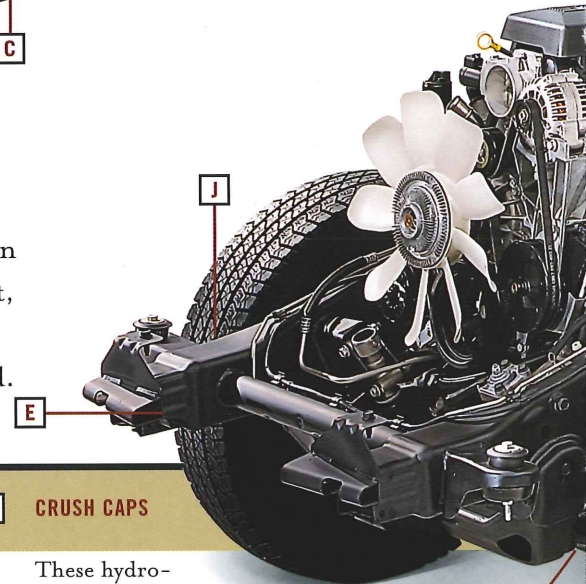

**A DENT-RESISTANT STEEL**

The outer panels of the cab and front end are made from a more dent-resistant grade of steel than its predecessor.<sup>1</sup>

**B MAGNESIUM CROSSBEAM ASSEMBLY**

A super-strong yet lightweight crossbeam assembly of magnesium alloy and steel is located behind the instrument panel to help resist twisting forces.

**C LOW STEP-IN HEIGHT**

The frame design allows the step-in height of the cab floor to drop a full inch for easier access. Yet the Sierra's ground clearance is still ten inches.

**D IMPROVED FIT**

Tolerances for the Sierra's sheet-metal fit are tight, thanks to a frame design that precisely locates the mounting brackets on the frame rails.

**E CRUSH CAPS**

These hydro-formed caps help absorb frontal impact energy in a crash and help reduce repair costs.

**F**



**J** **HYDROFORMED FRONT RAILS**  
Formed from the inside out using pressurized fluid, the steel front frame rails are stronger and lighter than traditional boxed steel rails.



The front frame rails form a "closed section," a design that produces maximum torsional strength. Twists from the front suspension, for example, are resisted and ride quality improved.

**K** **ROLL-FORMED MID-RAILS**  
The Sierra's mid-rails are roll-formed and draw-bent from high-strength steel. It's a constant mid-rail section between cab and box, maximizing beam strength.



The mid-rail section is a "lipped" C-section, a design that starts with a strong C-section, then adds even more strength and rigidity by incorporating flanges or "lips" to the edge of the mid-rail to reinforce it.

**L** **STAMPED REAR RAILS**  
A strong straight-rail rear frame easily accepts trailer hitches and helps give the Sierra a maximum trailer weight rating of up to 11,200 pounds on 2WD models.<sup>2</sup>



The rear frame rail's C-section is the optimum design to carry the load from rear suspension components without adding weight.

**M** **TUBULAR CROSSMEMBERS**  
To increase frame rigidity, the Sierra uses a series of tubular crossmembers. Instead of using heavy stampings, our solution adds strength without adding weight.



The tubular crossmembers were incorporated for their ability to resist twisting forces acting on the main frame rails. Your ride is smooth and steady as a result.

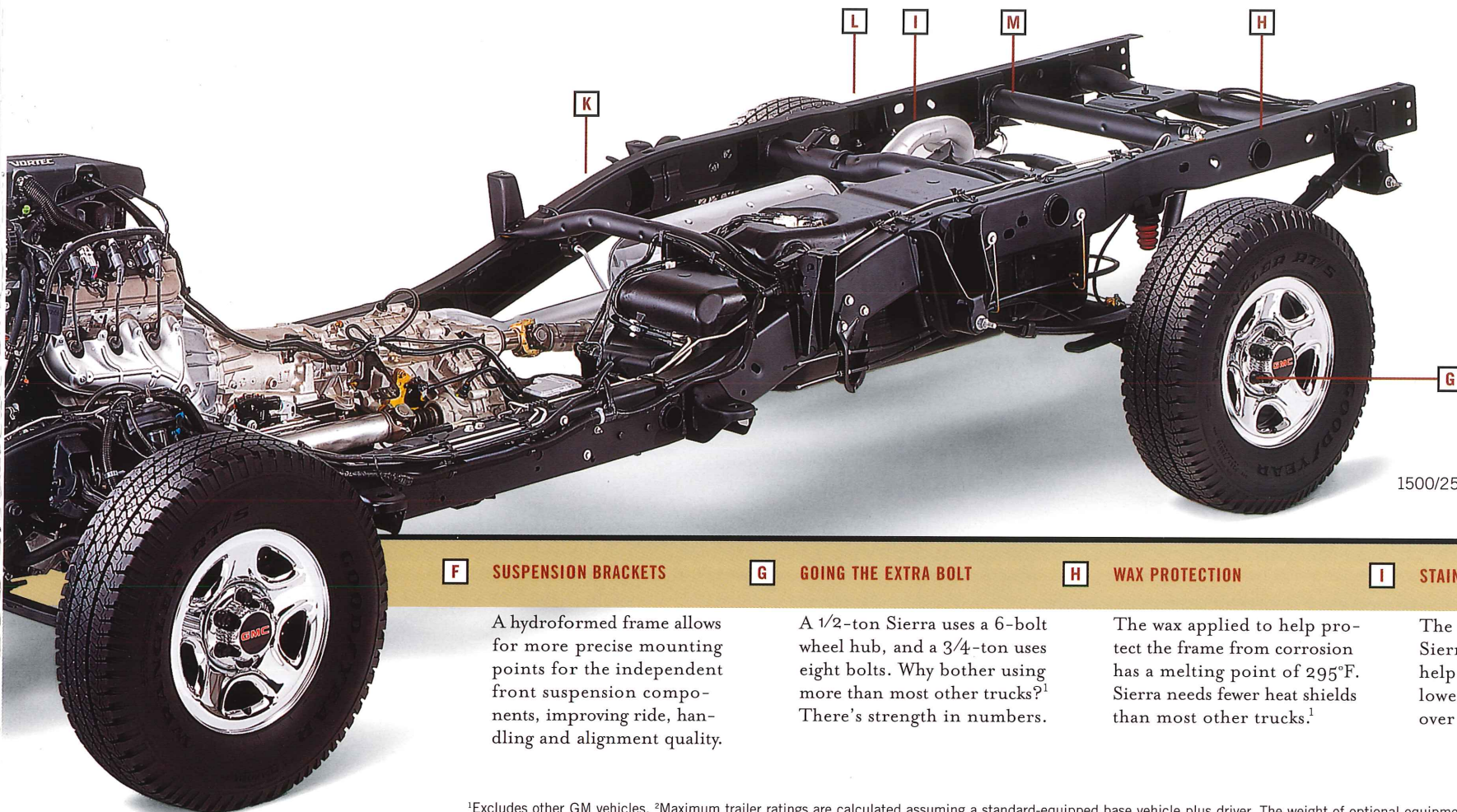

1500/2500 Series chassis shown

**F** **SUSPENSION BRACKETS**  
A hydroformed frame allows for more precise mounting points for the independent front suspension components, improving ride, handling and alignment quality.

**G** **GOING THE EXTRA BOLT**  
A 1/2-ton Sierra uses a 6-bolt wheel hub, and a 3/4-ton uses eight bolts. Why bother using more than most other trucks?<sup>1</sup> There's strength in numbers.

**H** **WAX PROTECTION**  
The wax applied to help protect the frame from corrosion has a melting point of 295°F. Sierra needs fewer heat shields than most other trucks.<sup>1</sup>

**I** **STAINLESS STEEL**  
The exhaust system on the Sierra is stainless steel to help ensure long life and lower maintenance costs over the long haul.

<sup>1</sup>Excludes other GM vehicles. <sup>2</sup>Maximum trailer ratings are calculated assuming a standard-equipped base vehicle plus driver. The weight of optional equipment, passengers, cargo and required trailering equipment will reduce the maximum trailer weight. See the *GMC Trailering Guide* for details.

**HEAVY-DUTY SIERRA TRUCKS FEATURE A MASSIVE CHASSIS DESIGNED TO STAND UP TO RUGGED USE AS WELL AS PROVIDE A SMOOTH RIDE.**

Both 2500HD and 3500 Series trucks use a multisectional modular frame design. This allows the front, mid and rear sections to be manufactured independently, with materials and processes best suited to helping each section meet its specific performance requirements without incurring weight penalties.

**ALL CHASSIS COMPONENTS, INCLUDING SUSPENSION SYSTEMS, BRAKES AND WHEELS, ARE ENGINEERED FOR HEAVY-DUTY USE.**

Sierra 2500HD models have two-stage multileaf springs; 3500 Series trucks have three-stage multileaf springs for extra strength. Standard four-wheel anti-lock disc brakes with Hydro-Boost™ operate with optimum pedal effort and provide impressive stopping power. Standard 16 x 6.5-inch, eight-bolt steel wheels are exceptionally heavy-duty.

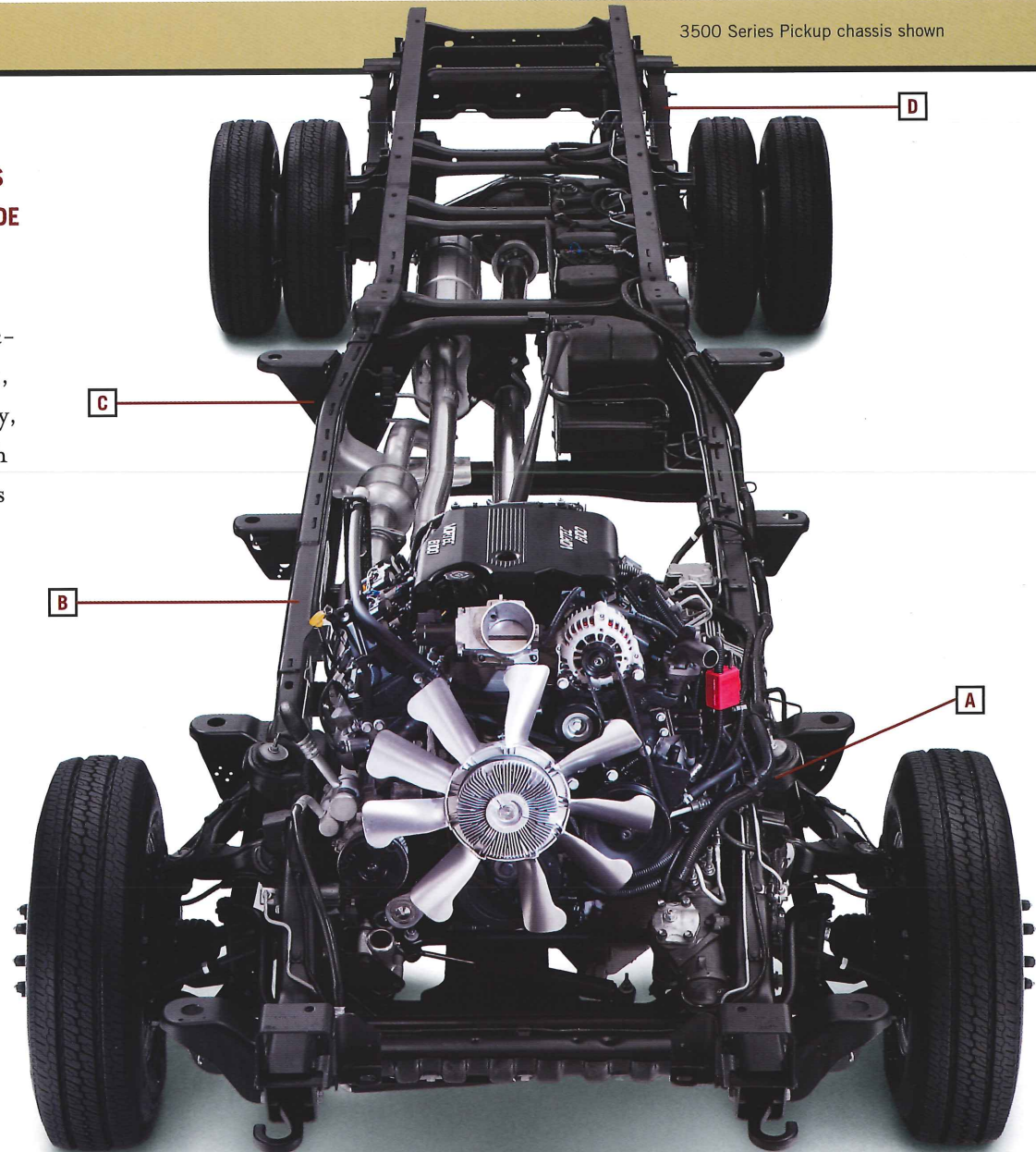

**A FRONT SUSPENSION**

Independent torsion-bar suspension allows high GVW ratings and outstanding load-carrying capability, and helps produce a smooth ride.

**B HYDROFORMING PROCESS**

Front frame section is hydroformed to increase structural rigidity by producing more consistent steel-wall thickness.

**C HIGH-STRENGTH STEEL**

Mid-frame section uses a lipped C-section and high-strength low-alloy steel, which is roll-formed and draw-bent during manufacturing for maximum strength (excludes Chassis Cab models).

**D REAR SUSPENSION**

Heavy-duty Sierra models feature twin-tube, gas-charged shock absorbers for a smooth ride under loaded and unloaded conditions.



SIERRA HEAVY-DUTY  
3500 SLT EXTENDED CAB  
in Summit White with 2WD and  
other available equipment.



◀ ▶

Whether it's loaded or unloaded, the Sierra is designed to perform equally well. The charts below highlight some of the ways that new technology is working to help keep you in command.



**LOADED TRUCK**

**PROBLEM**

Loaded, a pickup's braking should be well balanced, with the added weight on the rear axle helping reduce tire squeal. But the added weight also means it may not accelerate and shift crisply.

**SIERRA SOLUTION**

Selectable Tow/Haul mode automatic transmission builds more power for crisp shifts. Shift stabilization means less hunting for the right gear, and lets you tow in overdrive for improved efficiency.

**UNLOADED TRUCK**

**PROBLEM**

Unloaded, a pickup should give you good acceleration and crisp shifts. But in certain conditions, the lack of weight on the rear axle may cause tire squeal during braking.

**SIERRA SOLUTION**

Dynamic Brake Proportioning, which electronically reassigns the front-to-rear force, maximizing rear-wheel braking performance under varying payload and road conditions.



#### UPPER AND LOWER TIE-DOWNS

Tie-down anchors at the box rail and cargo floor help you position cargo securely within the bed.



#### TWO-TIER CARGO LOADING

Ledges in the sidewall of the bed let you create a two-tier cargo load. You'll be able to organize your loads for maximum security and efficiency.



#### TONNEAU COVER

Shield your truck's bed and cargo from weather with this embossed tonneau cover. An aluminum frame securely attaches to the bed with an exclusive clamp system that lets you lift the gate with the cover on.

## LESSON FIVE: JUST ENOUGH ISN'T ALWAYS GOOD ENOUGH.

**WANT A TRUCK THAT OPERATES CONSISTENTLY WITH OR WITHOUT A LOAD? THE SIERRA'S TOW/HAUL MODE, DYNAMIC BRAKE PROPORTIONING, AND CHOICE OF SUSPENSIONS HELP IT ACHIEVE BALANCED RIDE AND HANDLING LOADED OR UNLOADED.**

**TOW/HAUL MODE** Towing a trailer or hauling a load? Just push a button and the 2001 Sierra's Tow/Haul mode puts an end to shift busyness. No more hunting between gears when climbing hills. You get the same solid shift feel whether you're hauling cargo, towing a trailer or traveling light. An industry first,<sup>1</sup> the Tow/Haul feature gives our automatic transmissions a dual-mode shift program that can hold gears longer to put more torque where it's needed. Once you've got the load moving, the Tow/Haul mode helps you haul heavy loads in overdrive for less noise and improved fuel economy.

**FOUR-WHEEL ABS DISC BRAKES WITH DYNAMIC BRAKE PROPORTIONING** The brake system of the 2001 Sierra was designed especially for what the engineers call "predictable linear response." In other words, it's designed to behave the same whether the truck is loaded or empty. They specified ventilated disc brakes at all four wheels to help shed the heat that can rob you of crucial stopping performance. A four-wheel antilock brake system helps preserve steering control. Dynamic Brake Proportioning makes better use of the rear brakes by electronically modulating pressure for maximum effectiveness.

**SUSPENSION CHOICES** The 2001 Sierra offers five suspension packages. Why so many? Because we know that our customers have a wide range of needs. The chart below helps you understand the specific ride and handling characteristics of each system. Please see the specifications pages for more information on the base and optional suspension system applications.



			1500/2500 SERIES	2500HD/3500 SERIES
Z83	<b>SOLID, SMOOTH RIDE</b>	Standard on the 2001 Sierra, Z83 is designed for ride comfort under all conditions.	•	N/A
Z85	<b>HANDLING/TRAILERING</b>	This system increases damping for a firmer ride and handling.	•	•
Z71	<b>OFF-ROAD</b>	Features gas-charged shocks tuned for the large suspension inputs of rigorous off-roading.	•	N/A
ZX3	<b>MANUAL SELECTABLE</b>	Lets you choose between smooth (Z83) or firm (Z85) shock dampings for ride and handling.	•	N/A
VYU	<b>SNOWPLOW PREP PACKAGE</b>	Provides increased front torsion spring rate with greater carrying capacity (4WD only).	•	•

<sup>1</sup>Excludes other GM vehicles.



SIERRA HEAVY-DUTY  
2500HD SLT CREW CAB  
in Pewter with 4WD and  
other available equipment.



#### TOW HOOKS

To match their higher GCVR, all heavy-duty trucks have large, strong tow hooks with an interchangeable side-to-side design.



#### EXTENDABLE MIRRORS

The retractable camper mirror option is one of three mirror options available. Also available are power mirrors and power/heated mirrors.

**MANUAL SELECTABLE SUSPENSION (ZX3)** The 1500/2500 Sierra offers you a great way to tailor the ride and handling of a truck to meet your needs. Need to tow a trailer? For optimum stability and comfort, press a button mounted on the instrument panel; the available shock valving feature lets you specify a firm setting when you're hauling or towing a heavy load. Press the button again to switch back to the normal state for a smooth, relaxed ride.

**ENGINE GRADE-BRAKING** For outstanding control when trailering—especially downhill—heavy-duty (2500HD/3500) Sierra trucks with the Allison 1000 Series five-speed automatic transmission include an advanced grade-braking capability. When this feature is activated in Tow/Haul mode, the transmission automatically downshifts when the brakes are applied to help slow the vehicle when descending a steep grade.

**TRAILER-READY DESIGN** Sierra heavy-duty trucks are designed specifically for the rigors of trailering and hauling. With a GM fifth-wheel or gooseneck trailer hitch, the Vortec 8.1-liter engine or Duramax turbo diesel provide trailer weight capacities approaching 16,000 pounds.<sup>1</sup> A variety of components further enhance towing/hauling capabilities. For example, 1500/2500 Series trucks provide a six-wire lead as standard equipment, while 2500HD/3500 Series pickups have an eight-wire lead. The special RPO Z82 equipment trailering provisions package is also available (see right). For peace of mind, a transmission fluid temperature gauge (standard with 4L80-E four-speed and Allison 1000 Series five-speed automatic transmissions) monitors heat buildup and alerts the driver when the fluid exceeds the normal operating range.



Heavy-duty Sierra front suspension torsion bars are computer-selected for the vehicle's particular application to optimize ride and handling.

#### TRAILERING PACKAGE (Z82)

An optional heavy-duty trailering equipment package for the Sierra combines several features that should make it easy for you to get going with your gear in tow. For starters, the package includes a weight-distributing platform hitch. And pre-wired seven-pin connectors make the electrical hookup of your trailer a snap.

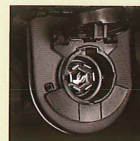

Note: Ordering optional heavy-duty trailering equipment package Z82 requires that you also specify an upgraded suspension (Z85, Z71 or ZX3).

<sup>1</sup>Maximum trailer ratings are calculated assuming a standard equipped base vehicle plus driver. See the GMC Trailering Guide for details.



SIERRA 1500 SLT  
WITH STANDARD REAR DOORS  
in Fire Red with  
4WD and other  
available equipment.



## LESSON SIX: A TRUCK'S MOST VITAL CARGO IS THE KIND THAT SITS INSIDE.

### SIERRA'S STANDARD REAR DOORS OPEN TO MORE REAR LEGROOM THAN ANY OTHER FULL-SIZE EXTENDED CAB PICKUP.<sup>1</sup>

Sierra is professional grade. It not only gives you what other trucks do, but a little extra. For example, Sierra doesn't just offer you a fourth door. It offers you rear doors with the widest openings and lowest step-in height of any extended cab pickup truck in its class.<sup>1</sup>

Sierra's rear doors let adults get into and out of the cab easily. Without inhaling deeply. Or tucking knees into their chest. With the standard 40/20/40 front bench seat, Sierra's fourth door extended cab can comfortably seat up to six adults.

Now sit down in the Sierra. You'll have more front headroom and rear legroom than in any other extended cab pickup truck in its class.<sup>1</sup> Seat travel is designed to accommodate 98 percent of all drivers. And the front safety belts are mounted in the seats for more comfort and ease of use.



#### MORE REAR-SEAT COMFORT



Back-seat passengers enjoy best-in-class legroom.<sup>1</sup> The seat itself offers dual adjustable head restraints, a relaxed seat-back angle, a tall seatback and a long seat cushion.

#### LOW STEP-IN HEIGHT



The Sierra's spacious interior is easy to get into and out of, no matter what your attire. Step-in height at the floor is a full inch lower than its predecessor<sup>2</sup> — without losing any of Sierra's ground clearance.

#### ONSTAR<sup>®</sup>



OnStar<sup>3</sup> is activated with the push of a button or automatically in the event of air-bag deployment. It pinpoints your location using global positioning satellite technology and can send help to wherever you are.

<sup>1</sup>Excludes other GM vehicles. Based on extended cab pickups. <sup>2</sup>Compared to 1998 model year Sierra. <sup>3</sup>One-year OnStar Safety & Security agreement included as standard on Sierra SLT models, scheduled for availability fall 2000. For system limitations and details, call 1-800-ONSTAR-7.



SIERRA 1500 SLT INTERIOR  
with front leather seating  
surfaces in Pewter. Shown with  
available equipment.



SIERRA 1500 SLT INTERIOR  
with leather seating surfaces  
in Pewter. Shown with  
available equipment.

**ONE OF THE FIRST THINGS YOU'LL NOTICE ABOUT THE 2001 SIERRA IS HOW QUIET IT IS.**

One reason: the doors feature a double seal, similar to those used in luxury sedans to help thwart wind noise. Of course, if you want to fill the silence with sound, Sierra can do that, too. Four superb sound systems are available, including optional systems that feature six speakers for the finest in audio reproduction. Filling the inside of your Sierra with your stuff is no problem. Those big convenience-store cups fit in the front and rear cupholders. All doors have deep-pocket storage. On Extended Cab models, an overhead storage console with map lights is standard and can be upgraded to add compartments for sunglasses and a garage door opener. One thing that won't fill up the interior is the sun's heat: tinted Solar-Ray® glass helps keep you and the cabin cool.

**EXTENDED CAB REAR CARGO AREA**

Fold up the Sierra's rear seat and you'll have plenty of room for all your stuff. A total of 49.7 cubic ft. of cargo room.

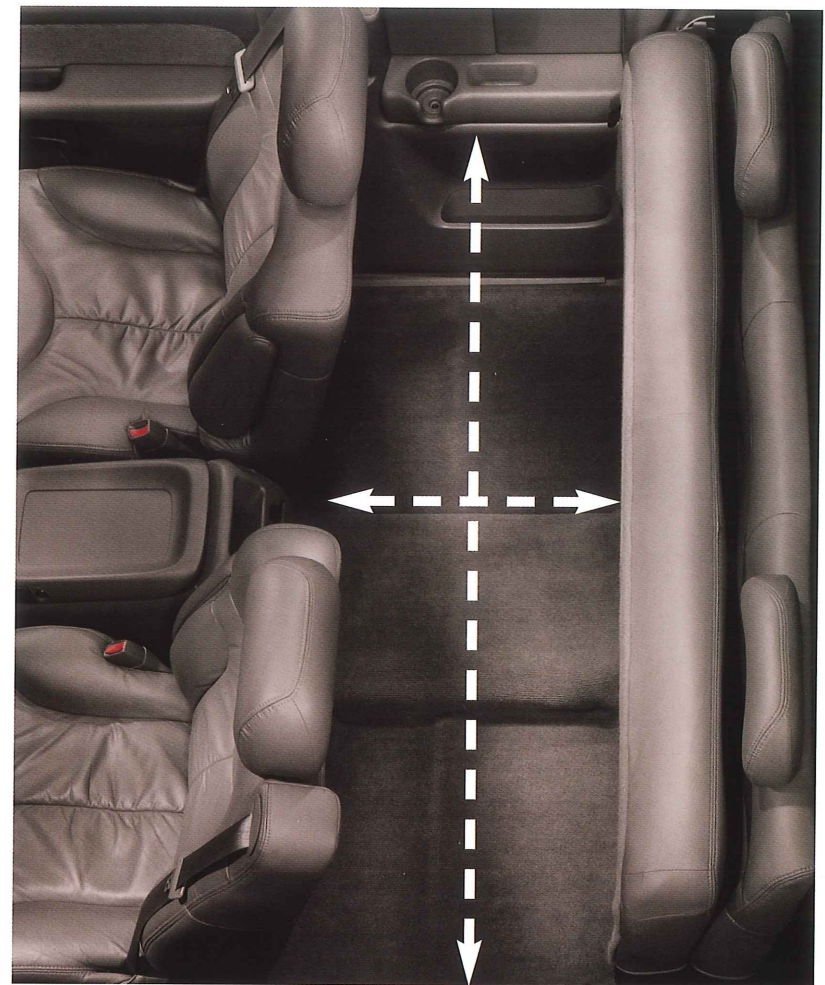

**PREMIUM SOUND SYSTEMS**

Sierra SLE and SLT models feature a standard AM/FM stereo with CD player and enhanced six-speaker sound system. Both models also offer an optional unit that includes an AM/FM stereo with cassette and CD player, enhanced six-speaker system and Theftlock® security system.

**PREMIUM FRONT BUCKET SEATS (AN3)**



The Sierra lets you tailor your comfort with available power adjustments. Shown are controls for driver's-seat memory and heated-seat features, available on SLT Extended Cab models only.

**INTEGRATED SAFETY BELTS**

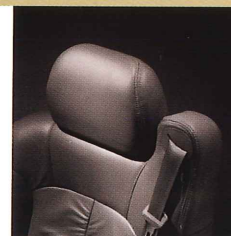

The front safety belts in the Sierra are integrated into the seat, so they fit comfortably no matter where you move your seat. They make getting in and out of the rear seat easier, too.



**SIERRA HEAVY-DUTY 3500 SLE  
CREW CAB INTERIOR**  
with custom cloth seats in Neutral.  
Shown with available equipment.

**THE ALL-NEW HEAVY-DUTY 2500HD AND 3500 SERIES SIERRA TRUCKS ARE DESIGNED FOR EXCEPTIONAL COMFORT.** Sierra Regular, Extended and Crew Cab models provide a roomier interior and more in-cab storage room than the models they replace.<sup>1</sup> Compared to the competition, the Sierra offers the largest rear door openings of any extended cab models in its class.<sup>2</sup>

All heavy-duty models offer a 40/20/40 front bench seat that provides full three-across seating.

In vehicles with bucket seats, a floor console features a large, lockable storage area, cupholders, stowage integral to the lid and a coin holder. In Extended Cab and Crew Cab models, the rear seat provides three-across seating — and the console also includes rear-seat cupholders, adjustable rear air-conditioning vents with positive shutoffs and a rear-seat stowage bin.

#### YOU'RE IN CHARGE OF THE AIR IN THERE

The Sierra puts you in control of a quick, quiet heating and air-conditioning system. You can control not just the temperature, but the fan speed and outlet location, and choose to recirculate cabin air. With available air conditioning, an air filter screens dust and pollen as small as ten microns. The Sierra offers standard rear-floor heating ducts in Extended Cab and Crew Cab models.



#### SPLIT-BENCH SEAT WITH ARMREST STORAGE

Sierra's standard cloth bench seat is anything but ordinary. Fold the center section up for a padded seat-back. Fold it down for an armrest that opens to reveal storage big enough for a notebook computer.

#### OVERHEAD CONSOLE



The overhead console has easily accessible controls for both standard and optional features. Includes map/reading lights for driver and passenger, and an eyeglass holder.

#### DOOR HANDLES YOU CAN HANDLE



The large door handles are easy to grab, pull and release with a natural motion. A helpful interior release handle has been added to the fourth door and the doors automatically unlock when the key is removed from the ignition.

#### MIRROR FEATURE



The available light-sensitive inside rearview mirror helps reduce glare behind you, and even provides a compass and outside temperature readout.

<sup>1</sup>Compared to 2000 model year 3500 Series Sierras. <sup>2</sup>Excludes other GM vehicles.

# LESSON SEVEN: VALUE IS SOMETHING YOU PROVE ONE DOOR SLAM AT A TIME.

**THE 2001 SIERRA IS DESIGNED FOR THE LONG HAUL.** Take the door, for example. It's proven itself durable enough to pass a door-closing test that slammed the door closed 400,000 times – equivalent to ten door slams a day for 109 years. Here are some of the other features of the Sierra, designed to help add longevity and control operating costs.



## DRIVER MESSAGE CENTER...

displays the status of up to 18 vital vehicle functions, including progressively warning the driver of more serious situations, so corrective measures can be taken. You can fix problems before they get out of hand.

## UP TO 100,000 MILES BEFORE THE FIRST SCHEDULED TUNE-UP<sup>1</sup>...

on Sierra's Vortec engines, thanks to features like platinum-tipped spark plugs, long-life coolant and a one-piece serpentine drive belt.

## TRANSMISSION TEMPERATURE GAUGE...

monitors the transmission fluid temperature on all 2500HD/3500 models with automatic transmission and with the Vortec 6000 V8, automatic transmission and Z82 trailering package.

## ENGINE HOUR METER...

makes it easy for you to base preventative maintenance schedules on the whole truth: not merely on the miles run, but on total hours logged.

## BATTERY RUNDOWN PROTECTION...

helps prevent battery drainage by turning off the interior lights or cargo box light if you forget.

## HEAT MANAGEMENT...

is critical in designing durability into an engine. The Vortec V8s have an extra-wide radiator and an aluminum-bodied high-capacity pump to help keep things cool.



## LONG-LIFE FLUIDS



Our advanced Dex-Cool<sup>®2</sup> engine coolant inhibits corrosion and is designed to go up to five years/150,000 miles before its first scheduled change.<sup>1</sup> That's like driving from New York to L.A. – 50 times.

## AIR FILTER GAUGE



Monitoring your engine's air filter is easy. A convenient indicator located on the air intake tells you precisely when it's time to change filters, for the most cost-effective maintenance.

## ELECTRICAL SYSTEM

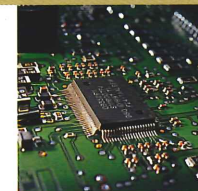

The electrical center reduces the number of wiring splices by 94%, to just six. It's more reliable, and plugging in auxiliary electronics, such as those for snowplows and trailer lighting, is easy.



SIERRA  
SPORT SPECIAL EDITION  
in Fire Red with 2WD and  
other available equipment.

# LESSON EIGHT: AN ACCIDENT WAITING TO HAPPEN CAN PROBABLY BE AVOIDED.

WITH A STANDARD 4-WHEEL DISC ANTILOCK BRAKE SYSTEM AND OPTIONAL AUTOTRAC AUTOMATIC 4-WHEEL DRIVE, THE 2001 SIERRA BRINGS A NEW LEVEL OF CRASH-AVOIDANCE ENGINEERING TO THE FULL-SIZE PICKUP TRUCK SEGMENT.



You are looking at a ventilated disc brake rotor. Ventilating the disc rotors helps dissipate the heat that's created whenever the brakes are applied. By helping to reduce the source of brake fade and wear, the ventilated disc brakes play an important role in improving the Sierra's stopping performance.

Four of these disc brakes – working with an antilock braking system (ABS) and Dynamic Brake Proportioning – are included as standard equipment on the Sierra. It's an integrated system designed to help you stop and steer on wet roads or dry, under heavy loads or light.

The discs are massive pieces of hardware. In fact, they use the largest disc pads on any Extended Cab full-size pickup! Further improvements to the brake system result in a brake pedal effort that is more akin to a sport or luxury vehicle. And even stopping distances are better than before.



## A MORE EFFECTIVE RANGE



The Sierra's headlamps have an effective low-beam range of 385 feet, and a high-beam of 695 feet. More usable light means more time for you to react – an especially important consideration when towing a trailer.



## VISIBLE DAY AND NIGHT

The Daytime Running Lamps (DRLs) shown here turn on automatically when you drive, improving Sierra's visibility to others during daylight hours. Nightfall automatically switches the DRLs off and the headlamps on.

## AMBER TURN SIGNALS



The Sierra's large rear turn signal lenses are amber. The color separation helps to clearly communicate what your intentions are to the drivers around you.

The Sierra's strategy for maximum traction control includes another engineering first: Autotrac™, the first automatic 4-wheel-drive system ever available on a full-size pickup truck.<sup>1</sup>

Available on 1500/2500 4x4 models, Autotrac is simple to use. You select Auto 4WD mode, and Sierra's active transfer case automatically transfers power to the front axle to help reduce rear wheel slip and restore optimum traction. It automatically returns to 2WD whenever 4WD traction isn't needed, to help optimize fuel efficiency.

On 2500HD/3500 heavy-duty models, the conventional electronic push-button 4WD feature is available.

Ordering your Sierra with the optional locking differential gives you even more traction control. Its durable carbon-fiber friction plates ensure consistent engagement and add longer life.



**AUTOTRAC AUTOMATIC 4WD.** When you engage the Automatic 4WD mode, the system detects wheel slippage and automatically transfers torque to the front wheels for enhanced traction, and then returns to two-wheel drive as conditions warrant. (1500/2500 models only)

**2WD HIGH-RANGE.** When conditions don't require the added benefits of Autotrac, the system allows you to engage only rear-wheel drive for improved fuel efficiency.

**NEUTRAL.** Want to tow your new Sierra? Just select Neutral to flat tow. There's no need to disconnect any part of the driveline.

**4WD HIGH-RANGE.** You can also choose to manually activate the 4WD transfer case, selecting 4WD HI when you anticipate the need to operate only in 4WD near or at highway speeds.

**4WD LOW-RANGE.** Got a situation that calls for low-range traction? Simply engage Sierra's 4WD low-range. You can tap your engine's deep reserves of torque to help pull your boat up a ramp. Or use your engine's braking power to ease you down an incline.

#### REMOTE KEYLESS ENTRY WITH PANIC BUTTON



The optional remote keyless entry has a vehicle locator/panic button, to help you find your truck or announce an emergency. And only your truck will recognize your key that is part of the PassLock® II theft deterrent system.

#### SIDE DOOR BEAMS



The Sierra provides side-impact protection with high-strength steel front door beams.

#### AIR BAG DEACTIVATION SWITCH



We've included a passenger-side air bag deactivation switch for use when carrying children.

Always use safety belts and proper child restraints. See the *Owner's Manual* for more safety information and refer to "A Note on Child Safety" on page 48.



SIERRA SPORT SPECIAL EDITION  
in Fire Red with 2WD and  
other available equipment.

SIERRA 1500 SLT EXTENDED CAB  
in two-tone Fire Red over  
Pewter with 4WD and other  
available equipment.



SIERRA HEAVY-DUTY  
2500HD SLT CREW CAB  
in Pewter with 4WD and  
other available equipment.



SIERRA HEAVY-DUTY  
3500 SLE CREW CAB  
in White with 4WD and  
other available equipment.

# LESSON NINE: A TRUCK IS SOMETHING PEOPLE TEND TO TAKE PERSONALLY.

**GM ACCESSORIES HELP YOU GET THE MOST OUT OF YOUR SIERRA. DESIGNED ESPECIALLY FOR YOUR VEHICLE, THE QUALITY ACCESSORIES SHOWN HERE ARE JUST A SAMPLE OF WHAT'S AVAILABLE.<sup>1</sup>**

Our Bed Rack is a unique cargo-carrying system made from corrosion-proof, anodized aluminum. It mounts in the stake pockets of your Sierra. Two base rails, two sliding overhead racks and four sliding crossbar tie-downs make up the system. The Bed Rack weighs less than 80 lbs and can shoulder a capacity of 750 lbs.



The Hitch-Mounted Ski Carrier holds up to four pairs of skis or four snowboards. With a foot-operated lever tilt-down, you can open the tailgate to access the cargo bed.



Tote up to four bikes and leave the bed free for additional storage with our Hitch-Mounted Bicycle Carrier. The rack adjusts to fit many bike styles. Twelve-foot cable lock straps are included for extra security.



## HOT/COLD BEVERAGE HOLDER



Electric cupholder adjusts to keep your hot drinks a constant 155 degrees or cold drinks 37 degrees. The unit fits directly onto the center console and comes with two GMC logo mugs.

## MOLDED SPLASH GUARDS

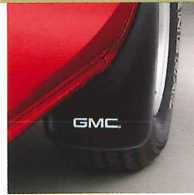

Custom-molded to provide an exact fit, these splash guards look great while protecting your Sierra from mud, dirt, snow, salt and gravel. Will not chip, crack or fracture. Cannot be used with fender flares.

## COLOR-KEYED RUNNING BOARDS



These newly designed running boards not only complement your Sierra's styling, but also have integrated front and rear splash guards for added protection. Built to handle a 500-lb load, the running boards feature a black step pad for safe footing.

The Truck Bed Tent turns your Sierra into a camper in a matter of minutes. This two-person tent fits snugly into the truck bed and features a reinforced polyurethane mesh floor and waterproof vents covering four large mesh windows. It fits into a small pouch for storage behind the front seat.



#### CHROME TUBULAR SIDE STEPS

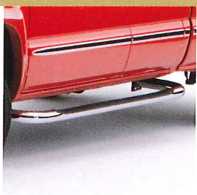

The integrated appearance of these tubular side steps adds to the stylish looks of the Sierra, and makes entering and exiting your Sierra easier. Available in chrome or black, they mount to existing holes and require no drilling.

#### HOOD AIR DEFLECTOR



Protect against paint damage from stone chips and insects with this UV-stable, black acrylic deflector. Mounts easily to the hood without drilling, and allows for cleaning of hood under protector.

#### CUSTOM CARPET FLOOR MATS



Floor mats conform to the interior contours for an excellent fit and customized look. Carpet mats are quality-constructed for long life, and they're treated to repel water. Front mats feature the GMC logo.

## COLORS

## WHEEL FLARE DETAIL

### SOLID PAINT TREATMENT

(Standard)



Fire Red



Indigo Blue



Polo Green



Dark Toreador Red



Storm Gray



Topaz Gold



Onyx Black



Sunset Orange

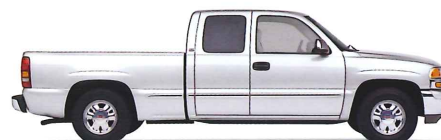

Summit White



Pewter



Wheel flares are standard on all 2500/2500HD/3500 models and are available on 1500 Series 4WD models.

### SOLID COLOR COMBINATIONS (ZY1)

Exterior Paint Colors	Available Interior Colors			Wheel Flare Colors	
	Neutral	Pewter	Graphite	SL	SLE/SLT
Summit White (50)	•	•	•	Black	Black <sup>2</sup>
Storm Gray (14)	•	•	•	Black	Storm Gray
Pewter (11)	•	•	•	Black	Pewter
Indigo Blue (39)	•	•	•	Black	Black
Polo Green (47)	•	•	•	Black	Polo Green
Fire Red (74)	•	•	•	Black	Black
Dark Toreador Red (51) <sup>1</sup>	•	•	•	Black	Black
Onyx Black (41)	•	•	•	Black	Black
Sunset Orange (71) <sup>1</sup>	•	•	•	Black	Black
Topaz Gold (60) <sup>1</sup>	•	•	•	Black	Topaz Gold

<sup>1</sup> These colors require SLE or SLT models. All exterior colors are metallic except Fire Red, Onyx Black and Summit White. All colors are basecoat/clearcoat for high-gloss and durable finish. See dealer for more details. <sup>2</sup>Color will be Summit White interim 2001 model year.



### TWO-TONE PAINT TREATMENT<sup>3</sup>

(Available on SLE and SLT models with E63 wideside body)

### TWO-TONE COLOR COMBINATIONS (ZY2)

Exterior Upper Paint Colors	Exterior Lower Paint Color	Available Interior Colors			Wheel Flare Colors
		Neutral	Pewter	Graphite	SLE/SLT
Summit White (50)	Pewter (11)		•	•	Pewter
Polo Green (47)	Pewter (11)	•	•	•	Pewter
Indigo Blue (39)	Pewter (11)	•	•	•	Pewter
Fire Red (74)	Pewter (11)	•	•	•	Pewter
Dark Toreador Red (51)	Pewter (11)	•	•	•	Pewter
Onyx Black (41)	Pewter (11)		•	•	Pewter
Storm Gray (14)	Pewter (11)		•	•	Pewter
Topaz Gold (60)	Pewter (11)	•	•		Pewter

<sup>3</sup>Top of front bumper on 1500/2500 Series matches lower body paint color; top of front bumper on 2500HD/3500 Series is black.



Neutral

Graphite

Pewter



**SLT (Leather)**

Reclining high-back bucket seats<sup>1</sup> with leather seating surfaces<sup>2</sup> and 6-way power adjustments, air conditioning, AM/FM stereo with CD player, electrochromic rearview mirror, power windows/door locks/mirrors, remote keyless entry and bright exterior trim.



**SLE (Up-level Cloth)**

Reclining 40/20/40 split-bench seat with fold-down armrest<sup>2</sup>; air conditioning, AM/FM stereo with CD player, cruise control, power windows/door locks/mirrors, remote keyless entry and bright exterior trim.



Graphite

Neutral



**SL (Up-level Cloth)**

Reclining 40/20/40 split-bench seat with fold-down armrest, AM/FM stereo, multiple power outlets, full-floor carpeting, automatic headlamps, theft deterrent system and intermittent windshield wipers.

1500 SERIES



**STANDARD**

16-inch, 6-lug painted steel wheel (standard on SL)



**PF9**

16-inch, 6-lug painted aluminum wheel (available on SL, SLE and SLT)



**PY2**

16-inch, 6-lug chrome steel wheel (standard on SLE and SLT)



**PF4**

16-inch, 6-lug bright machined aluminum wheel (available on SLE and SLT)



**QC3**

16-inch, 6-lug polished aluminum wheel (available on SLE and SLT)

2500/2500HD SERIES



**STANDARD**

16-inch, 8-lug painted steel wheel (standard on SL)



**P03**

16-inch, 8-lug painted steel wheel with chrome center cap (available on SL)



**PY2**

16-inch, 8-lug chrome steel wheel (standard on SLE and SLT)



**PY0**

16-inch, 8-lug polished aluminum wheel (available on SLT)

3500 SERIES



**STANDARD**

16-inch, 8-lug, steel wheel (standard on SL)



**P06**

16-inch, 8-lug, steel wheel with chrome center caps and trim rings

<sup>1</sup> 40/20/40 split-bench seat also available. <sup>2</sup> Rear seat in Extended Cab models features simulated leather trim. <sup>3</sup> High-back bucket seats with cloth trim also available.

INTERIOR	SL	SLE	SLT
<b>Air Bags:</b> <sup>1</sup> Driver and front passenger (includes front-passenger deactivation switch) <sup>2</sup>	S	S	S
<b>Air Conditioning:</b> Non-CFC refrigerant	A	S	S
<b>Assist Handle:</b> Front passenger-side (plus rear outboard positions on Extended Cabs)	S	S	S
<b>Audio Systems:</b> AM/FM stereo with seek/scan and digital clock (2 speakers on Regular Cabs; 4 speakers on Extended Cabs) (UL1/UM7)	S	—	—
AM/FM stereo with cassette player, seek/scan, digital clock and 4-speaker sound system (UM6)	A	—	—
AM/FM stereo with CD player, seek/scan, digital clock, automatic tone control, speed-sensitive volume, Theftlock® security system and enhanced 6-speaker system (UN0)	—	S	S
AM/FM stereo with cassette and CD players, seek/scan, digital clock, automatic tone control, speed-sensitive volume, auto-reverse cassette, music search, Theftlock security system and enhanced 6-speaker system (UP0) <sup>3</sup>	—	A	A
<b>Cigarette Lighter</b>	S	S	S
<b>Console, Extended Overhead:</b> Includes two adjustable reading lamps, two storage compartments and garage door opener compartment (Extended Cabs only; requires bucket seats)	—	S	S
<b>Cruise Control</b>	A	S	S
<b>Cupholders:</b> Two, seat-mounted (plus two rear on Extended Cabs)	S	S	S
<b>Door Locks:</b> Programmable	A	S	S
<b>Door Trim:</b> Side reflectors	S	—	—
Side reflectors with lights	—	S	S
<b>Floor Covering:</b> Full-floor interior-colored carpeting	S	S	S
<b>Driver Information Center:</b> Monitors up to 18 different systems, including transmission overheat, low fuel and low coolant	S	S	S
<b>Floor Mats:</b> Vinyl, front (plus rear on Extended Cabs)	S	S	S
<b>Gauges:</b> Full instrumentation, including speedometer, tachometer, odometer, trip odometer, fuel level, voltmeter, engine temperature and oil pressure, plus Driver Message Center and engine-hour meter	S	S	S
<b>Headlamps:</b> With automatic control and lights-on warning tone	S	S	S
<b>Headliner:</b> Interior-colored cloth	S	S	S
<b>Heater/Defogger:</b> With front side-window defoggers	S	S	S
<b>Heater Ducts:</b> Rear (Extended Cabs only)	S	S	S
<b>Illuminated Entry</b>	—	S	S
<b>Lighting:</b> Courtesy, glovebox, ashtray, dome, reading and under-hood lamps	S	S	S

	SL	SLE	SLT
<b>Mirror:</b> Rearview day/night mirror	S	S	S
Electrochromic rearview mirror with 8-point compass	—	S	S
<b>OnStar®</b>	—	—	S
<b>Power Outlets:</b> Dual dash-mounted	S	S	S
<b>Power Windows:</b> With lighted switches and express-down feature on driver's window	—	S	S
<b>Safety Belts:</b> Front: Seat-mounted outboard lap and shoulder belts, and center lap belt. Rear: Outboard lap and shoulder belts, and center lap belt (Extended Cabs only)	S	S	S
<b>Seats, Extended Cab:</b> Front 40/20/40 split bench with folding armrest storage compartment, manual lumbar adjusters, recliners and adjustable outboard head restraints (Up-level Cloth)	S	S	—
Front 40/20/40 split bench with folding armrest storage compartment, manual lumbar adjusters, recliners, power adjustments and adjustable outboard head restraints (Front leather seating areas)	—	—	S
Front high-back buckets with folding armrests, manual lumbar adjusters, recliners, power adjustments and overhead/floor consoles (Up-level Cloth)	—	A	—
Front high-back buckets with folding armrests, manual lumbar adjusters, recliners, power adjustments and overhead/floor consoles (Front leather seating areas)	—	—	A
Front full-feature high-back buckets with folding armrests, power lumbar adjusters, power recliners, power adjustments, 2-position heat, 2-position driver's memory, adjustable/articulating head restraints and overhead/floor consoles (Front leather seating areas)	—	—	A
6-way power front seats	—	A	S
Rear bench seat with adjustable outboard head restraints (Up-level Cloth on SL and SLE, simulated leather on SLT)	S	S	S
<b>Seats, Regular Cab:</b> Front 40/20/40 split bench with folding armrest storage compartment, manual lumbar adjusters, recliners and adjustable outboard head restraints (Up-level Cloth)	S	S	—
Front high-back buckets with folding armrests, manual lumbar adjusters, recliners, power adjustments and overhead/floor consoles (Up-level Cloth)	—	A	—
6-way power driver's seat	—	A	—
<b>Steering Wheel:</b> Simulated leather	S	—	—
Leather-wrapped	—	S	S
Tilt capability	S	S	S
<b>Sunshades:</b> With passenger-side vanity mirror	S	S	S

## STANDARD AND AVAILABLE EQUIPMENT

For more information, visit [gmc.com/sierra](http://gmc.com/sierra) 

EXTERIOR	SL	SLE	SLT
<b>Air Dam:</b> Light charcoal	S	S	S
<b>Box:</b> Wideside, with two-tier loading capability	S	S	S
Sportside (1500 short-box models only)	A	A	A
<b>Bumper, Front:</b> Chrome with black trim	S	—	—
Chrome with body-color trim	—	S	S
<b>Bumper, Rear:</b> Painted, with black step pad	S	—	—
Chrome, with black step pad	A	S	S
<b>Cargo Lamps:</b> Dual, independently switched	S	S	S
<b>Center High-Mounted Stop Lamp:</b> Additional brake light for improved visibility to rear traffic	S	S	S
<b>Daytime Running Lamps:</b> Independent automatic	S	S	S
<b>Fog Lamps</b>	—	A	A
<b>Grille:</b> Black with light argent surround	S	—	—
Black with chrome surround	—	S	S
<b>Headlamps:</b> Halogen composite	S	S	S
<b>Mirrors:</b> Dual foldaway, black	S	—	—
Dual power control, with bright trim	—	S	S
Dual high-visibility extendable trailering	A	A	A
Electrochromic heated driver's mirror with power control	—	A	A
<b>Molding:</b> Black bodyside	A	—	—
Bright bodyside	—	S	S
<b>Rear Doors, Driver and Passenger:</b> (Extended Cabs only)	S	S	S
<b>Recovery Hooks:</b> Front frame-mounted	S	S	S
<b>Remote Keyless Entry:</b> Includes two transmitters	—	S	S
<b>Side Door Beams:</b> Front doors	S	S	S
<b>Tailgate:</b> Theft-deterrent with protective cap	S	S	S
<b>Tire and Wheel, Spare:</b> Full-size, with lockable hoist and spare tire retrieval tool	S	S	S
<b>Tires:</b> Five steel-belted radials; see your GMC dealer for specifications	S	S	S
<b>Tonneau Cover</b> (Wideside only)	A	A	A
<b>Wheel Flares</b>			
1500 (4WD)	A	A	A
2500 (2WD & 4WD)	S	S	S
<b>Wheels:</b> Painted steel with black center cap	S	—	—
Chrome steel	A	S	S
Machined aluminum	—	A	A
Polished aluminum	—	A	A
<b>Window Equipment:</b> Tinted Solar-Ray® glass	S	S	S
Deep-tinted Solar-Ray glass on side-rear and rear windows (Extended Cabs only)	A	A	A
Intermittent wet-arm windshield wipers/washer	S	S	S
Rear window defogger	A	A	A
Swing-out quarter window (Extended Cabs only)	S	S	S

MECHANICAL	SL	SLE	SLT
<b>Air Cleaner:</b> With maintenance indicator	S	S	S
<b>Battery:</b> With rundown protection and retained accessory power	S	S	S
<b>Brakes:</b> Four-wheel ventilated disc	S	S	S
Four-wheel antilock system	S	S	S
<b>Brakes/Transmission Shift Interlock:</b> Safety feature with automatic transmission	S	S	S
<b>Camper Wiring Equipment (UY2):</b> Includes 7-wire connector at front of box	A	A	A
<b>Chassis Equipment:</b> (See your dealer for availability) Solid, smooth ride (Z83)	S	S	A
Handling/trailering: with blue Monroe™ gas shocks on 1500 series (Z85)	A	A	S
Off-road: includes underbody skid plates, heavy-duty air cleaner, red Monroe gas shocks and suspension jounce bumpers (4WD 1500 only) (Z71)	—	A	A
Manual selectable: driver-adjustable for smooth ride or increased handling/trailering, with orange DeCarbon™ gas shocks (ZX3)	—	A	A
<b>Cooling:</b> Long-life Dex-Cool® engine coolant (up to 5-year/150,000-mile change interval) <sup>4</sup>	S	S	S
Heavy-duty engine oil cooling	S	S	S
Heavy-duty transmission cooling	S	S	S
Heavy-duty auxiliary automatic transmission cooling	A	A	A
<b>Differential, Locking Rear:</b> <sup>5</sup> With carbon-fiber plates	A	A	A
<b>Engine Block Heater:</b> For cold climates	A	A	A
<b>Exhaust:</b> Aluminized stainless steel exhaust system	S	S	S
<b>PassLock II Theft Deterrent System</b>	S	S	S
<b>Power Steering</b>	S	S	S
<b>Shield Package, Underbody (NZZ):</b> Includes front underbody, oil pan, differential and transfer case skid plates (4WD models only)	A	A	A
<b>Snowplow Prep Package (VYU):</b> Includes heavy-duty front springs, heavy-duty automatic transmission cooling, electrical relays and heavy-duty shocks (4WD only)	A	A	A
<b>Trailer Equipment:</b> Heavy-duty 6-wire harness	S	S	S
Heavy-duty equipment (includes platform hitch & 7-wire connector)	A	A	A
<b>Transfer Case (4WD models only):</b> Manual Insta-Trac® shift-on-the-fly 4WD with floor shifter	S	S	—
Autotrac™ automatic push-button active transfer case	—	A	S

S = Standard A = Available — = Not Available

For specification details and other available equipment, see your GMC dealer. Some of the available features listed here may be included in, or ordered only with, specific marketing packages or special packages. Some of the features listed here may not be available on certain versions of the SL.

<sup>1</sup> Always use safety belts and proper child restraints, even with air bags. See *Owner's Manual* for more safety information and refer to "A Note on Child Safety" on page 48. <sup>2</sup> Deactivation switch for use when carrying children.<sup>3</sup> Available only with automatic transmission, Extended Cab and bucket seats. <sup>4</sup> Maintenance needs vary with different uses and driving conditions. Vehicles with DEX-COOL brand coolant must be refilled only with DEX-COOL. See your *Owner's Manual*. <sup>5</sup> Limited to certain axle ratios. See your GMC dealer for details.

## ENGINE SPECIFICATIONS

Engine	Vortec 4300 V6	Vortec 4800 V8	Vortec 5300 V8	Vortec 6000 V8
Fuel Type	Gasoline	Gasoline	Gasoline	Gasoline
Capacity	4.3 liters (262 cu in)	4.8 liters (293 cu in)	5.3 liters (325 cu in)	6.0 liters (364 cu in)
Ordering Code	L35	LR4	LM7	LQ4
Bore and Stroke (mm)	101.60 x 88.39	96.01 x 83.00	96.01 x 92.00	101.60 x 92.00
Compression Ratio	9.2:1	9.5:1	9.5:1	9.4:1
Valve Train	Overhead valve	Overhead valve	Overhead valve	Overhead valve
Fuel Delivery	Sequential fuel injection	Sequential fuel injection	Sequential fuel injection	Sequential fuel injection
SAE Net Horsepower @ RPM (automatic transmission)	200 @ 4600	270 @ 5200	285 @ 5200	300 @ 4400
SAE Net Torque @ RPM (lb-ft)	260 @ 2800	285 @ 4000	325 @ 4000	360 @ 4000

## ENGINE/MODEL AVAILABILITY

S = Standard A = Available — = Not Available

1500:	Regular Cab, short box	S	A	A	—
	Regular Cab, long box	S	A	A	—
	Extended Cab, short box	—	S	A	—
2500:	Regular Cab, long box	—	—	S	A
	Extended Cab, short box	—	—	S	A

## TRANSMISSIONS

Electronic 4-speed automatic with overdrive and 5-speed manual with overdrive are available, depending upon engine and body-style combinations, and are subject to emissions requirements.

## STANDARD TECHNICAL DATA

Series/Drive Type	1500/2WD	1500/4WD	2500/2WD	2500/4WD
Brakes	Power 4-wheel ventilated disc	Power 4-wheel ventilated disc	Power 4-wheel ventilated disc	Power 4-wheel ventilated disc
Steering	Power rack-and-pinion	Power recirculating ball	Power recirculating ball	Power recirculating ball
Fuel Tank Capacity (gallons)	26.0 <sup>1</sup> /34.0 <sup>2</sup>	26.0 <sup>1</sup> /34.0 <sup>2</sup>	34.0 <sup>2</sup>	26.0 <sup>1</sup>
DELCO® Freedom® Battery (cold cranking amps)	600	600	600	600
Alternator (amps)	105	105	105	105
<b>Gross Vehicle Weight Rating (GVWR)<sup>3</sup></b>				
Regular Cab (lbs)	6100 <sup>1</sup> /6400 <sup>2</sup>	6100 <sup>1</sup> /6400 <sup>2</sup>	8600	8600
Extended Cab (lbs)	6200	6400	8600	8600

## FRONT SUSPENSION

1500—Independent coil springs (2WD); independent torsion bars (4WD) 2500—Independent torsion bars (2WD/4WD)

<b>Axle capacity</b>				
Regular Cab (lbs)	3150	3925	3800 <sup>4</sup>	4250
Extended Cab (lbs)	3600	3925	3800 <sup>4</sup>	4250
<b>Spring capacity</b>				
Regular Cab (lbs)	2950 <sup>1</sup> /3150 <sup>2</sup>	—	3600 <sup>4</sup>	—
Extended Cab (lbs)	3500	—	3600 <sup>4</sup>	—
<b>Torsion bar capacity</b>				
Regular Cab (lbs)	—	3600	4250	4250
Extended Cab (lbs)	—	3600	4250	4250

## REAR SUSPENSION

Semi-elliptic 2-stage multileaf springs

<b>Axle capacity</b>				
Regular Cab (lbs)	3750	3750	4800 <sup>4</sup> /6000 <sup>4</sup>	6000
Extended Cab (lbs)	3750	3750	4800 <sup>4</sup> /6000 <sup>4</sup>	6000
<b>Spring capacity (lbs)</b>	3750	3750	4800 <sup>4</sup> /6084 <sup>4</sup>	6084

<sup>1</sup>Short box. <sup>2</sup>Long box. <sup>3</sup>When properly equipped; includes weight of vehicle, passengers, cargo and equipment. <sup>4</sup>Capacities and weight ratings are dependent upon model, engine, transmission and GVWR combinations. See your GMC dealer for details.

**TRAILERING DATA: MAXIMUM GROSS COMBINED WEIGHT RATING BASED ON ENGINE AND REAR AXLE RATIO**

Gross Combined Weight Rating (lbs)	Rear Axle Ratio with Automatic Transmission								Rear Axle Ratio with Manual Transmission						
	9000	9500	10,000	11,000	12,000	13,000	14,000	16,000	8000	8500	9000	10,000	11,000	14,000	16,000
Vortec 4300 V6 gasoline (L35)	3.08	3.42	3.73	—	—	—	—	—	3.08	3.42	3.73	—	—	—	—
Vortec 4800 V8 gasoline (LR4)	—	—	—	3.42	3.73	4.10	—	—	—	—	3.42	3.73	4.10	—	—
Vortec 5300 V8 gasoline (LM7)	—	—	—	—	3.42	3.73	4.10	—	—	—	—	—	—	—	—
Vortec 6000 V8 gasoline (LQ4)	—	—	—	—	—	—	3.73	4.10 <sup>1</sup>	—	—	—	—	—	3.73	4.10

<sup>1</sup>GCWR limited to 14,000 lbs on K15 models (except K15743).

Note: Your vehicle may require additional special equipment to tow the maximum trailer weight listed here. Maximum trailer weight ratings are based on Regular Cab models and calculated assuming a standard-equipped base vehicle plus driver. Trailer ratings for Extended Cab models will be reduced. The weight of optional equipment, passengers, cargo and required trailering equipment will also reduce the maximum trailer weight your truck can tow. Trailer tongue weight should be 10%–15% of total loaded trailer weight (up to 1,000 lbs on 1500 Series and 1,500 lbs on 2500 Series). Addition of trailer tongue weight cannot cause vehicle weights to exceed Rear Gross Axle Weight Rating (RGAWR) or Gross Vehicle Weight Rating (GVWR). See your *GMC Trailering Guide* for more details.

**DIMENSIONS**

**REGULAR CAB**

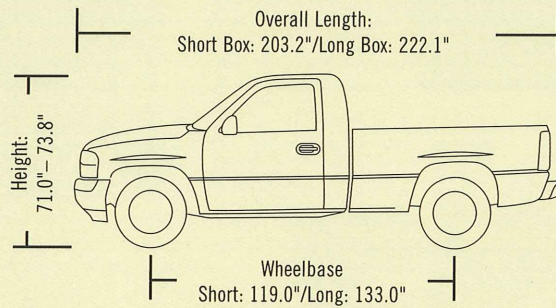

**EXTENDED CAB**

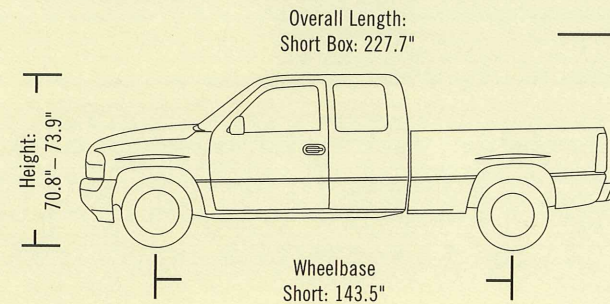

**SHORT BOX CARGO VOLUME: 56.9 CU FT**

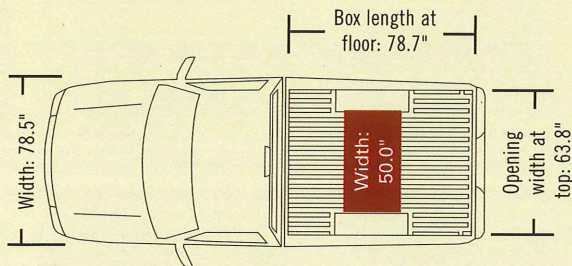

**LONG BOX CARGO VOLUME: 70.7 CU FT**

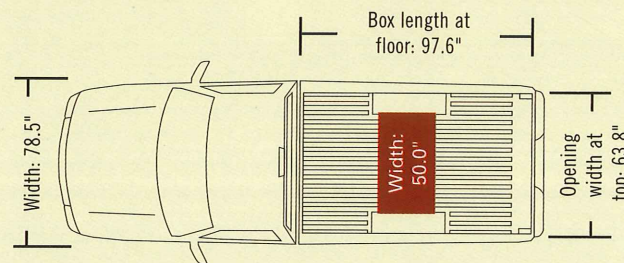

**SPORTSIDE BOX CARGO VOLUME: 43.5 CU FT**

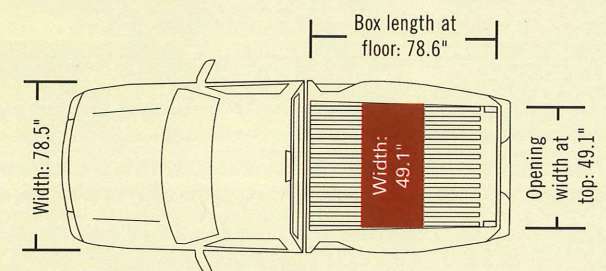



SIERRA HEAVY-DUTY  
3500 SLT EXTENDED CAB  
in Summit White with 2WD  
and other available equipment.

<sup>1</sup>When properly equipped; includes weight of vehicle, passengers, cargo and equipment. <sup>2</sup>Maximum trailer ratings are calculated assuming a standard-equipped base vehicle plus driver. The weight of optional equipment, passengers, cargo and required trailering equipment will reduce the maximum trailer weight. For specific weight ratings and hitch requirements, please refer to the charts on page 47. <sup>3</sup>Excludes other GM vehicles.

## ALL-NEW SIERRA 2500HD/3500 SERIES

**THE BIGGER THE JOB, THE MORE YOU'LL APPRECIATE THE CAPABILITIES OF THE ALL-NEW SIERRA 2500HD AND 3500 SERIES TRUCKS.** Need to haul a king-size load? Heavy-duty 3/4-ton 2500HD trucks have a gross vehicle weight rating (GVWR) of 9,200 lbs, while 3500 Series pickups have a GVWR of 11,400 lbs.<sup>1</sup> They also offer equally impressive trailering capabilities. 2500HD Series trucks have a maximum trailer weight rating up to 15,800 lbs, and 3500 Series trucks have a maximum rating up to 15,600 lbs.<sup>2</sup>

Their heavy-duty performance is the result of a combination of factors. Powerful Vortec V8 engines and an optional all-new Duramax™ turbo diesel. Rugged transmissions, including an Allison 1000 Series 5-speed automatic with an exclusive<sup>3</sup> grade braking feature. And a strong, solid chassis and rugged suspension system. Count in the fact they're available with Regular, Extended or Crew Cab, 2WD or 4WD, short box, long box or Chassis Cab, and you'll find there's a GMC heavy-duty truck that's exactly right for your needs.



**HEAVY-DUTY 2500HD CREW CAB**



**HEAVY-DUTY 3500 CREW CAB**

All-new Sierras are also available in Chassis Cab configurations up to 12,000 lbs GVWR.<sup>1</sup> Classic Sierras are available as Chassis Cabs up to 15,000 lbs GVWR.<sup>1</sup> Please refer to the GMC commercial catalog for complete details.

INTERIOR	SL	SLE	SLT
<b>Air Bags:</b> <sup>1</sup> Driver and front passenger (includes front-passenger deactivation switch) <sup>2</sup>	S	S	S
<b>Air Conditioning:</b> Non-CFC refrigerant	A	S	S
<b>Assist Handle:</b> Front passenger-side (plus rear outboard positions on Extended and Crew Cabs)	S	S	S
<b>Audio Systems:</b> AM/FM stereo with seek/scan, digital clock and 4 speakers	S	—	—
AM/FM stereo with cassette player, seek/scan, digital clock and 4-speaker sound system	A	—	—
AM/FM stereo with CD player, seek/scan, digital clock, automatic tone control, speed-sensitive volume, Theftlock® security system and enhanced 6-speaker system (Extended and Crew Cab only)	—	S	S
AM/FM stereo with cassette and CD players, seek/scan, remote digital clock, selective tone control, speed-sensitive volume, Theftlock security system and enhanced 6-speaker system (Extended and Crew Cab only)	—	A	A
<b>Cigarette Lighter:</b> On instrument panel	S	S	S
<b>Consoles:</b> Overhead and floor consoles included in models with front bucket seats	—	S	S
<b>Cruise Control</b>	A	S	S
<b>Cupholders:</b> Two, seat-mounted, plus two rear in Extended and Crew Cab	S	S	S
<b>Door Locks:</b> Programmable	A	S	S
<b>Door Trim:</b> Side reflectors	S	—	—
Side reflectors with lights	—	S	S
<b>Driver Information Center:</b> Monitors up to 18 different systems, including transmission overheat, low fuel and low coolant	S	S	S
<b>Floor Covering:</b>			
Full-floor interior-colored carpeting	S	S	S
Full-floor rubber mats	—	A	A
Front removable rubber floor mats	S	S	S
Front and rear removable rubber floor mats (Extended and Crew Cab only)	S	S	S
<b>Gauges:</b> Full instrumentation, including speedometer, tachometer, odometer, trip odometer, fuel level, voltmeter, engine temperature and oil pressure, plus Driver Message Center and engine hour meter	S	S	S
<b>Headlamps:</b> With automatic control and lights-on warning tone	S	S	S
<b>Headliner:</b> Interior-colored cloth	S	S	S

	SL	SLE	SLT
<b>Heater/Defogger:</b> With front side-window defoggers	S	S	S
<b>Heater Ducts:</b> Rear (Extended and Crew Cabs only)	S	S	S
<b>Illuminated Entry</b>	—	S	S
<b>Instrumentation:</b> Needle-type speedometer, odometer with trip odometer, voltmeter, engine hour meter, analog tachometer	S	S	S
<b>Lighting:</b> Courtesy, glovebox, ashtray, dome, reading and under-hood lamps	S	S	S
<b>Mirror:</b> Rearview day/night mirror	S	S	S
Electrochromic rearview mirror with 8-point compass	—	A	S
<b>OnStar®</b>	—	—	S
<b>Power Outlets:</b> Dual dash-mounted	S	S	S
<b>Power Windows:</b> With lighted switches and express-down feature on driver's window	A	S	S
<b>Safety Belts:</b> Front: Seat-mounted outboard lap and shoulder belts, and center lap belt. Rear: Outboard lap and shoulder belts, and center lap belt (Extended and Crew Cabs only)	S	S	S
<b>Seats:</b> Front 40/20/40 3-passenger split bench with Custom Cloth, center folding armrest storage compartment, manual lumbar adjusters, driver and passenger reclining, adjustable outboard head restraints	S	S	—
Front 40/20/40 3-passenger split bench with leather seating surfaces, center folding armrest storage compartment, manual lumbar adjusters, driver and passenger reclining, power driver and passenger adjustments, and adjustable outboard head restraints. Extended and Crew Cab: Rear 3-passenger folding bench seat with head restraints and leather-like vinyl	—	—	S
Front reclining bucket seats with Custom Cloth, inboard armrests, dual adjustable head restraints, manual lumbar adjusters and forward-folding driver's seat	—	A	—
Front reclining bucket seats with leather seating surfaces, inboard armrests, dual adjustable head restraints, manual lumbar adjusters, 6-way power driver and passenger seat adjusters and forward-folding driver's seat	—	—	A
Front full-feature bucket seats with leather seating surfaces, power lumbar adjusters, power adjustments, power seatback recliner, dual inboard armrests, heated driver and passenger cushion backs	—	—	A
6-way power-driver's seat	—	A	S
<b>Steering Wheel:</b> Simulated leather	S	—	—
Leather-wrapped	—	S	S
Tilt capability	S	S	S
<b>Sunshades:</b> With passenger-side vanity mirror	S	S	S

## STANDARD AND AVAILABLE EQUIPMENT

For more information, visit [gmc.com/sierra](http://gmc.com/sierra) 

EXTERIOR	SL	SLE	SLT
<b>Air Dam:</b> Light charcoal	S	S	S
<b>Box:</b> Wideside, with two-tier loading capability	S	S	S
<b>Bumper, Front:</b> Chrome with black trim	S	S	S
<b>Bumper, Rear:</b> Chrome, with black step pad	A	S	S
<b>Cargo Lamps:</b> Dual, independently switched	S	S	S
<b>Center High-Mounted Stop Lamp</b> Additional brake light for improved visibility to rear traffic	S	S	S
<b>Daytime Running Lamps:</b> Independent automatic	S	S	S
<b>Fog Lamps</b>	—	A	A
<b>Grille:</b> Black with chrome surround with chrome horizontal bars	S	S	S
<b>Headlamps:</b> Halogen composite	S	S	S
<b>Mirrors:</b> Dual foldaway, black	S	—	—
Dual power control, with bright trim	—	S	S
Dual high-visibility extendable trailering	A	A	A
Electrochromic heated driver's mirror with power control	—	A	A
<b>Molding:</b> Black bodyside	A	—	—
Bright bodyside	—	S	S
<b>Rear Doors, Driver and Passenger:</b> (Extended and Crew Cab)	S	S	S
<b>Recovery Hooks:</b> Front frame-mounted	S	S	S
<b>Remote Keyless Entry:</b> Includes two transmitters	—	S	S
<b>Side Door Beams:</b> Front doors	S	S	S
<b>Tailgate:</b> Theft-deterrent with protective cap	S	S	S
<b>Tire and Wheel, Spare:</b> Full-size, with lockable hoist and spare tire retrieval tool	S	S	S
<b>Tires:</b> Five steel-belted radials; see your GMC dealer for specifications	S	S	S
<b>Tonneau Cover:</b> (Wideside only)	A	A	A
<b>Wheel flares:</b> (2WD & 4WD)	S	S	S
<b>Wheels:</b> Painted steel with black center cap (2500HD)	S	—	—
Bright caps and trim rings (2500HD)	A	A	A
Chrome steel (2500HD)	—	S	S
Polished aluminum (2500HD)	—	A	A
<b>Wheels:</b> Painted steel with black center cap (3500)	S	S	S
Bright caps and trim rings (3500)	A	A	A
<b>Window Equipment:</b> Tinted Solar-Ray® glass	S	S	S
Deep-tinted Solar-Ray glass on side-rear and rear windows	A	A	S
Intermittent wet-arm windshield wipers/washer	S	S	S
Rear window defogger	A	A	A
Swing-out rear quarter window (Extended and Crew Cabs only)	S	S	S

MECHANICAL	SL	SLE	SLT
<b>Air Cleaner:</b> With maintenance indicator	S	S	S
<b>Battery:</b> With rundown protection and retained accessory power	S	S	S
<b>Brakes:</b> Four-wheel ventilated disc	S	S	S
Four-wheel antilock system	S	S	S
<b>Brakes/Transmission Shift Interlock:</b> Safety feature with automatic transmission	S	S	S
<b>Camper Wiring Equipment (UY2):</b> Includes 7-wire connector at front of box	A	A	A
<b>Chassis Equipment:</b> (See your dealer for availability) Handling/trailer package	S	S	S
<b>Cooling:</b> Long-life Dex-Cool® engine coolant (up to 5-year/150,000-mile change interval) <sup>4</sup>	S	S	S
Heavy-duty engine oil cooling	S	S	S
Heavy-duty transmission cooling	S	S	S
Heavy-duty auxiliary automatic transmission cooling	S	S	S
<b>Differential, Locking Rear:</b> <sup>5</sup> With carbon-fiber plates	A	A	A
<b>Engine Block Heater:</b> For cold climates	A	A	A
<b>Exhaust:</b> Aluminized stainless steel exhaust system	S	S	S
<b>PassLock® Theft Deterrent System</b>	S	S	S
<b>Power Steering</b>	S	S	S
<b>Shield Package, Underbody (NZZ):</b> Includes front underbody, oil pan, differential and transfer case skid plates (4WD models only)	A	A	A
<b>Snowplow Prep Package (VYU):</b> Includes heavy-duty front springs, heavy-duty automatic transmission cooling, electrical relays and heavy-duty shocks (4WD only)	A	A	A
<b>Trailer Equipment:</b> Heavy-duty 8-wire harness	A	A	A
Heavy-duty equipment (includes platform hitch & 7-wire connector)	A	A	A
<b>Transfer Case (4WD models only):</b> Manual Insta-Trac® shift-on-the-fly 4WD with floor shifter	S	S	S
Electronic push-button Insta-Trac 4WD	A	A	A

S = Standard A = Available — = Not Available

For specification details and other available equipment, see your GMC dealer. Some of the available features listed here may be included in, or ordered only with, specific marketing packages or special packages. Some of the features listed here may not be available on certain versions of the SL.

<sup>1</sup> Always use safety belts and proper child restraints, even with air bags. See *Owner's Manual* for more safety information and refer to "A Note on Child Safety" on page 48. <sup>2</sup> Deactivation switch for use when carrying children. <sup>3</sup> Available only with automatic transmission, Extended Cab and bucket seats. <sup>4</sup> Maintenance needs vary with different uses and driving conditions. Vehicles with DEX-COOL brand coolant must be refilled only with DEX-COOL. See your *Owner's Manual*. <sup>5</sup> Limited to certain axle ratios. See your GMC dealer for details.

## ENGINE SPECIFICATIONS

Engine	Vortec 6000 V8	Vortec 8100 V8	Duramax™ 6.6-Liter Turbo Diesel
Fuel Type	Gasoline (alternate fuel capability available)	Gasoline	Diesel
Capacity	6.0 liters (364 cu in)	8.1 liters (496 cu in)	6.6 liters (402 cu in)
Ordering Code	LQ4	L18	LB7
Bore and Stroke (mm)	101.6 x 92.0	107.95 x 111.0	103.00 x 99.00
Compression Ratio	9.4:1	9.1:1	NA
Valve Train	Overhead valve	Overhead valve	Overhead valve
Fuel Delivery	Sequential fuel injection	Sequential fuel injection	Direct fuel injection
SAE Net Horsepower @ RPM (automatic transmission)	300 @ 4400	340 @ 4200	300 @ 3100
SAE Net Torque @ RPM (lb-ft)	360 @ 4000	455 @ 3200	520 @ 1800

## ENGINE/MODEL AVAILABILITY

S = Standard A = Available -- = Not Available

2500HD: Regular Cab	S	A	A
Extended Cab	S	A	A
Crew Cab	S	A	A
3500: Regular Cab	S	A	A
Extended Cab	S	A	A
Crew Cab	S	A	A

## TRANSMISSIONS

With Vortec 6000 V8, heavy-duty five-speed manual is standard; electronically-controlled four-speed 4L80E automatic is optional.

With Vortec 8100 V8 or Duramax 6.6-liter turbo diesel, high-capacity six-speed ZF S6-650 manual is standard and Allison 1000 Series five-speed automatic is available.

## STANDARD TECHNICAL DATA

Series/Drive Type	2500HD/2WD	2500HD/4WD	3500/2WD	3500/4WD
Brakes (Hydro-Boost internal gear)	Power 4-wheel ventilated disc	Power 4-wheel ventilated disc	Power 4-wheel ventilated disc	Power 4-wheel ventilated disc
Steering	Power recirculating ball	Power recirculating ball	Power recirculating ball	Power recirculating ball
Fuel Tank Capacity (gallons)	26.0 <sup>1</sup> /34.0 <sup>2</sup>	26.0 <sup>1</sup> /34.0 <sup>2</sup>	34.0 <sup>2</sup>	34.0 <sup>2</sup>
Battery (cold cranking amps)	600	600	600	600
Alternator (amps)	105	105	105	105
<b>Gross Vehicle Weight Rating (GVWR)<sup>3</sup></b>				
All cab configurations (lbs)	9200	9200	11,400	11,400 (Pickup models) 12,000 (Chassis Cab models)

## FRONT SUSPENSION

(All models) Independent torsion bar

Axle capacity (lbs)	4410 <sup>4</sup> /4500 <sup>5</sup>	4500 <sup>6</sup> /4670 <sup>7</sup>	4500 <sup>8</sup> /4670 <sup>9</sup>	4670 <sup>10</sup> /4800 <sup>11</sup>
Torsion bar capacity (lbs)	4500	4500 <sup>12</sup> /4800 <sup>13</sup>	4500 <sup>14</sup> /4800 <sup>15</sup>	4500 <sup>16</sup> /4800 <sup>17</sup>

## REAR SUSPENSION

All models – Semi-elliptic; two-stage multileaf (2500HD), three-stage multileaf (3500) springs with gas-charged shocks

Axle capacity (lbs)	6084	6084	8550	8550 <sup>16</sup> /9000 <sup>17</sup>
Spring capacity (lbs)	6084	6084	8600	8600

<sup>1</sup>Short box. <sup>2</sup>Long box. <sup>3</sup>When properly equipped; includes weight of vehicle, passengers, cargo, and equipment. <sup>4</sup>Regular Cab long box and Extended Cab short box. <sup>5</sup>Extended Cab short box. <sup>6</sup>Regular Cab long box. <sup>7</sup>Extended Cab short box and Extended Cab long box. <sup>8</sup>Regular Cab long box and Extended Cab long box. <sup>9</sup>Crew Cab long box. <sup>10</sup>Regular Cab long box. <sup>11</sup>Extended Cab long box and Crew Cab long box. <sup>12</sup>Regular Cab long box and Crew Cab long box. <sup>13</sup>Extended Cab short box and Extended Cab long box. <sup>14</sup>Regular Cab long box. <sup>15</sup>Extended Cab long box and Crew Cab long box. <sup>16</sup>Regular Cab long box and Extended Cab long box. <sup>17</sup>Crew Cab long box. Capacities and weight ratings are dependent upon model, engine, transmission and GVWR combinations. See your GMC dealer for details.

**TRAILERING DATA: MAXIMUM GROSS COMBINED WEIGHT RATING BASED ON ENGINE AND REAR AXLE RATIO**

Gross combined weight rating (lbs)	Rear Axle Ratio with Automatic Transmission						Rear Axle Ratio with Manual Transmission		
	14,000	16,000	17,000	19,000	20,000	22,000	14,000	16,000	22,000
Vortec 6000 V8 gasoline (LQ4)	3.73	4.10	—	—	—	—	3.73	4.10	—
Vortec 8100 V8 gasoline (L18)	—	—	3.73	4.10	3.73	4.10	—	—	4.10
Vortec 6600 V8 Turbo Diesel (LB7)	—	—	—	—	—	3.73	—	—	3.73

Note: Your vehicle may require additional special equipment to tow the maximum trailer weight listed here. Maximum trailer weight ratings are based on Regular Cab models and calculated assuming a standard-equipped base vehicle plus driver. Trailer ratings for Extended Cab models will be reduced. The weight of optional equipment, passengers, cargo and required trailering equipment will also reduce the maximum trailer weight your truck can tow. Trailer tongue weight should be 10%–15% of total loaded trailer weight (up to 1,500 lbs on 2500HD or 3500 Series). Addition of trailer tongue weight cannot cause vehicle weights to exceed Rear Gross Axle Weight Rating (RGAWR) or Gross Vehicle Weight Rating (GVWR). See your *GMC Trailing Guide* for more details.

**DIMENSIONS**

**REGULAR CAB**

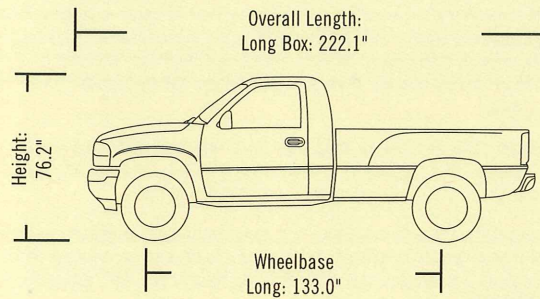

**EXTENDED CAB**

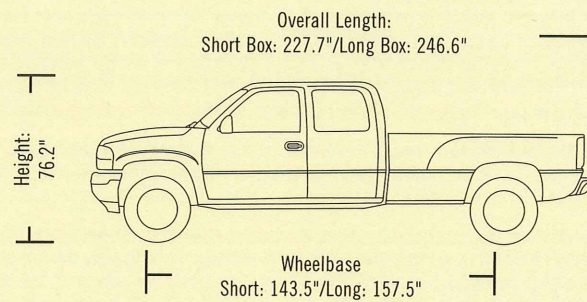

**CREW CAB**

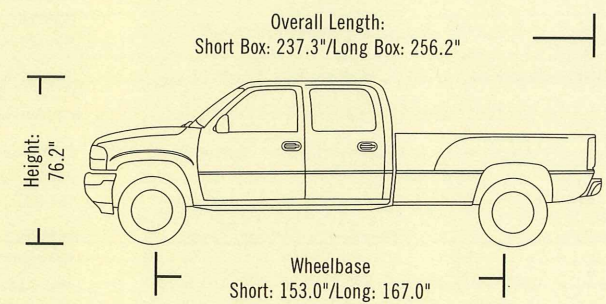

**SHORT BOX CARGO VOLUME: 56.9 CU FT**

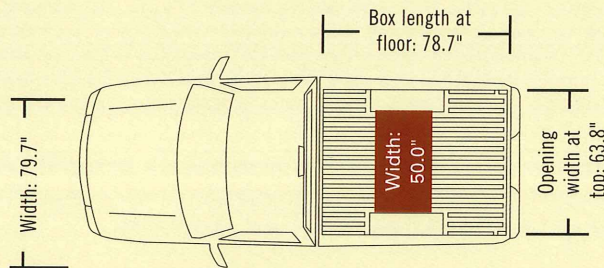

**LONG BOX CARGO VOLUME: 70.7 CU FT**

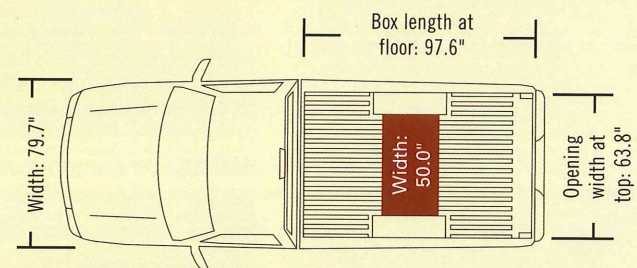

Sierra SLT models include a one-year Safety & Security package subscription<sup>1</sup> for the remarkable OnStar<sup>®</sup> service. OnStar<sup>2</sup> combines a unique blend of cutting-edge technology with attentive personal service to provide you with an unparalleled level of safety, security and information services. At the touch of a button, an OnStar Advisor is available to contact emergency service providers or roadside assistance. In an accident in which your air bags deploy, the OnStar system in your vehicle will automatically contact the OnStar Center. There, trained Advisors will immediately contact emergency assistance if needed and provide them with your Sierra's exact location. And, with OnStar MED-NET, your important medical history can be given to the emergency service providers and hospital. In the event of theft, OnStar can track your Sierra and help guide authorities to its location. If you lock your keys in your Sierra, an OnStar Advisor can send a signal to unlock your doors even from thousands of miles away.



<sup>1</sup> OnStar subscription service scheduled for availability fall 2000.

<sup>2</sup> Service contract required. Service will vary depending on your service plan. For system limitations and details, call 1-800-ONSTAR-7. OnStar uses existing emergency service providers and cellular telephone and satellite technologies.

**A Note on Child Safety** Always use safety belts and proper child restraints, even with air bags. Children are safer when properly secured in a rear seat. Never place a rear-facing infant restraint in the front seat of any vehicle equipped with an active air bag. See your vehicle Owner's Manual and child safety seat instructions for more safety information.

**Sierra Has Many Standard Safety Features Including:**

**Occupant Protection Equipment** Lap shoulder belts, rear outboard. Dual air bags on Sierra. Air bag suppression switch on vehicles under 8,600 lbs. Child comfort guides on rear outboard shoulder belts in crew cabs. Safety belt cinch capability for child seats.

**Crash-Avoidance Equipment** Four-wheel antilock brake system. Brake/transmission shift interlock. Automatic daytime running lamps. Door warning lights or reflectors. Maintenance-free battery. Tires with built-in tread wear indicators. Audible brake lining wear indicators with front disc brakes. Side window defogger, front. Tinted glass windshield.

**Theft-Deterrence Equipment** Laser-etched VIN plate. Theft-deterrent steering column lock. Single key system. Remote hood release. Marked body parts. PassLock<sup>®</sup> theft deterrent.

**Trailer with Your Sierra** Sierra is built strong and durable to handle the demands of towing. Certain equipment that prepares Sierra for trailering is standard on every Sierra: power steering, power brakes, 8-wire trailering harness, a large fuel tank, a 100-amp alternator and a front stabilizer bar. Also required, and available (some items are standard on certain models), are special transmission oil and engine oil coolers. For other available trailering-related equipment, talk to your dealer. You'll need a hitch, of course, and a wide selection of hitch types is available, usually either as factory equipment or from your dealer. In addition, if you plan to tow frequently, you should equip your Sierra with the available towing package (RPO Z82). This package includes a weight-distributing hitch platform. Also required with this package are a hitch ball, mounting head, and equalizing and antisway assemblies; these are available through aftermarket sources. If you have any questions about trailering with a Sierra, before you buy feel free to ask your dealer for a copy of the *GMC Trailering Guide*. Be sure to read it and use it as a guide before you hitch a trailer to your truck.

**Off-Road with Your Sierra** When you go off-road, you should take care to make sure your driving is appropriate to the vehicle and the environment. Avoid sharp turns and abrupt maneuvers. Failure to operate vehicles correctly off-road could result in loss of vehicle control or vehicle roll-over. When you are off-road, make sure that all cargo is properly loaded and secured. Use boxes to organize cargo and use nets and tie-downs to secure it. Wherever possible, use established trails, roads and other areas that have been set aside for public off-road recreational driving. And obey posted regulations. Don't drive on private property without the permission of the owner; in some states, you must have it in writing. Avoid any driving practice that could harm the environment or hurt wildlife, like wheel-spinning, breaking down trees, driving through streams or driving over soft ground. And never park your vehicle over dry grass or other materials that could catch fire from the heat of the vehicle's exhaust system.

**A Word About This Brochure** We have tried to make this brochure comprehensive and factual. We reserve the right, however, to make changes at any time and without notice, in prices, colors, materials, equipment, specifications, models and availability. Information may have been updated since the time of printing. Please check with your GMC dealer for complete details. GMC reserves the right to lengthen or shorten the model year for any product for any reason, or to start and end model years at different times.

**Assembly** GMC models and their components are assembled or produced by different operating units of General Motors, its subsidiaries or suppliers to General Motors worldwide. We sometimes find it necessary to produce GMC models with different or differently sourced components than originally scheduled. Since some options may be unavailable when your vehicle is assembled, we suggest you verify that your vehicle includes the equipment you ordered, or, if there are changes, that they are acceptable to you. GMC regularly sends its dealers useful GMC product service bulletins. To obtain these bulletins, ask your dealer or call 1-800-GMC-8782.

**Engines** GMC vehicles are equipped with engines produced by different operating units of GM, its subsidiaries or suppliers to GM worldwide.

**Tire Chains** If your Sierra has dual rear wheels or P265/75R16 size tires, tire chains should not be used because they could cause damage to your truck.



GMC supports the National SAFE KIDS Campaign,<sup>®</sup> a grassroots program dedicated to promoting child passenger safety.



GMC backs your new vehicle with its no-deductible, Bumper to Bumper limited warranty. The entire vehicle is warranted for repairs, including parts and labor, to correct problems in materials or workmanship, for three years or 36,000 miles, whichever comes first (except normal maintenance). Diesel engines are covered up to five years or 100,000 miles, whichever comes first (a deductible applies after three years/36,000 miles). The warranty covers towing to the nearest GMC dealership, and there is no deductible for warranty repairs during the warranty period. The warranty transfers automatically with vehicle ownership during the warranty period. GMCs are designed and built to resist corrosion. All body sheet metal components are warranted against rust-through corrosion for six years or 100,000 miles, whichever comes first. Application of additional rust-inhibiting materials is not required and none is recommended. See your GMC dealer for terms and conditions of these limited warranties.



Qualified approved customers can conveniently arrange GMAC<sup>®</sup> leasing and financing right at your GMC dealership. For more information, see your GMAC dealer or call 1-800-32-SMART.



The GM Card<sup>®</sup> — What are you charging toward?<sup>SM</sup> The GM Card rewards you 5% on every credit card purchase, making it the fastest way to save toward the GM car or truck of your dreams. For information or to apply for The GM Card, call 1-800-8GM-CARD or visit our website at [www.gmcard.com](http://www.gmcard.com).

**Information and Pricing**

See more of Sierra on our website [gmc.com/sierra](http://gmc.com/sierra) or call 1-800-GMC-8782 (1-800-462-8782).

- More photos and information
- Hot links to related subjects and features
- Convenient dealer locator
- Spec out your own vehicle
- Pricing Guide

All comparison claims are based on 2001 Sierra and 2000 competitive vehicles.

© 2000 GM Corp. All Rights Reserved. Buckle Up, America! Sierra, GM, GMC, the GMC logo, Delco, Freedom, Insta-Trac, Solar-Ray, Dex-Cool, OnStar, PassLock, The GM Card and design, and Commitment Plus and Commitment Plus design are registered trademarks of General Motors Corp. Autotrac, Do one thing. Do it well., and Vortec are trademarks of General Motors Corp. Theftlock is a registered trademark of Delco Electronics Corp. GMAC is a registered trademark of General Motors Acceptance Corp.

# COMMITMENT PLUS

From the owner orientation—and full tank of gas—you receive when you take possession of your Sierra to the **24-Hour Roadside Assistance**, **Courtesy Transportation** and **Travel Benefits**, **Commitment Plus** is a portfolio of owner privileges that lasts throughout your warranty. For expert product information, Roadside Assistance or other services, call 1-800-GMC-8782.

COMMITMENT  
PLUS

## GMC Orientation

- Thorough introduction to your Sierra
- Complimentary full tank of fuel



## PREMIUM Roadside Assistance

- Warranty towing, flat tire change, jumpstarts and more
- Available around the clock

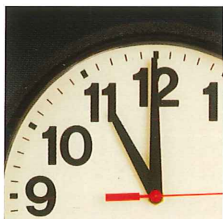

## Courtesy Transportation<sup>1</sup>

- Free one-way shuttle (up to 10 miles away)
- Reimbursement for alternate transportation (for overnight service)



## Travel Benefits

- Trip routing service
- Reimbursement for trip interruption (for warranty repairs)<sup>2</sup>

<sup>1</sup>Discuss the details with your dealer when making an appointment. <sup>2</sup>See your GMC dealer or call 1-800-GMC-8782 for complete details, including conditions and restrictions.

For more information, visit [gmc.com/sierra](http://gmc.com/sierra)

S  
I  
E  
R  
R  
A

2001



[gmc.com/sierra](http://gmc.com/sierra) 



36 USC 220506

**GMC**  
Official Sponsor of the  
U.S. Olympic Team

101-01 Litho in U.S.A.